

20 mm. A. A. GUN

20 MM. MACHINE GUN MECHANISMS MARKS 2 AND 4

20 MM. GUN BARRELS MARKS 2, 3, 4, AND 4 MOD. 1

20 MM. SIGHTS MARKS 2, 4, 4 MOD. 1, AND 5

20 MM. MAGAZINES MARKS 2 AND 4

20 MM. SHOULDER RESTS MARKS 2, 4, 5 AND 5 MOD. 1

DESCRIPTION



MARCH, 1943

NOTICE

Please make the following corrections on the pages listed below:

PAGE NO.	CORRECTION
85	Tenth line up from bottom of page— <i>change</i> —(300021-6) to read (300021-7).
86	Figure 70 at top of page— <i>change</i> (300021-6) to read (300021-7).
87	Twelfth line down from top of page— <i>change</i> —(300021-6) to read (300021-7).
87	Last paragraph on page— Alternate Rear Sight Pin Tips—Mark 5 Sight — <i>delete this entire paragraph.</i>

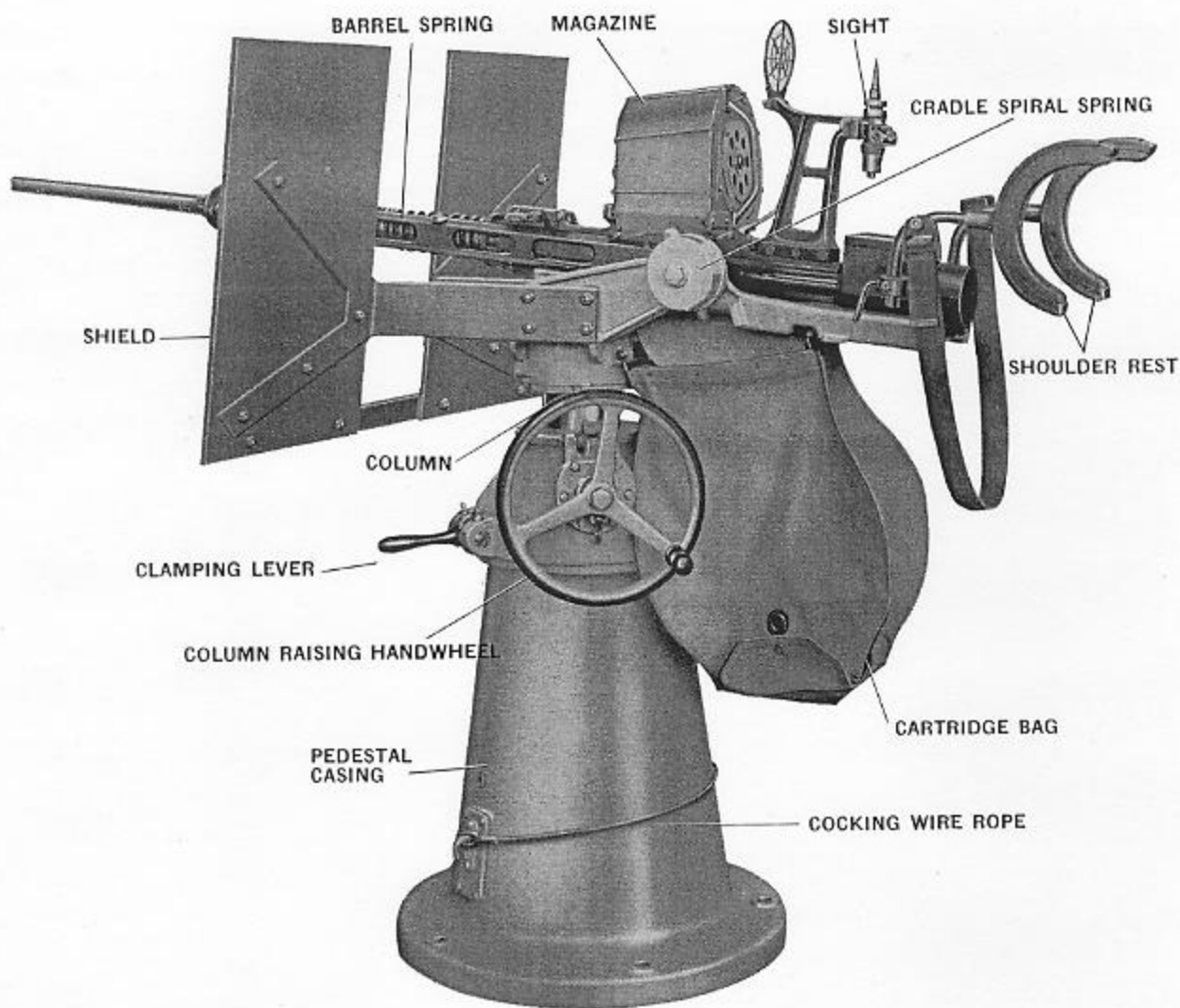

20 mm. A. A. Gun on Mark 4 Mod. 3 Mount

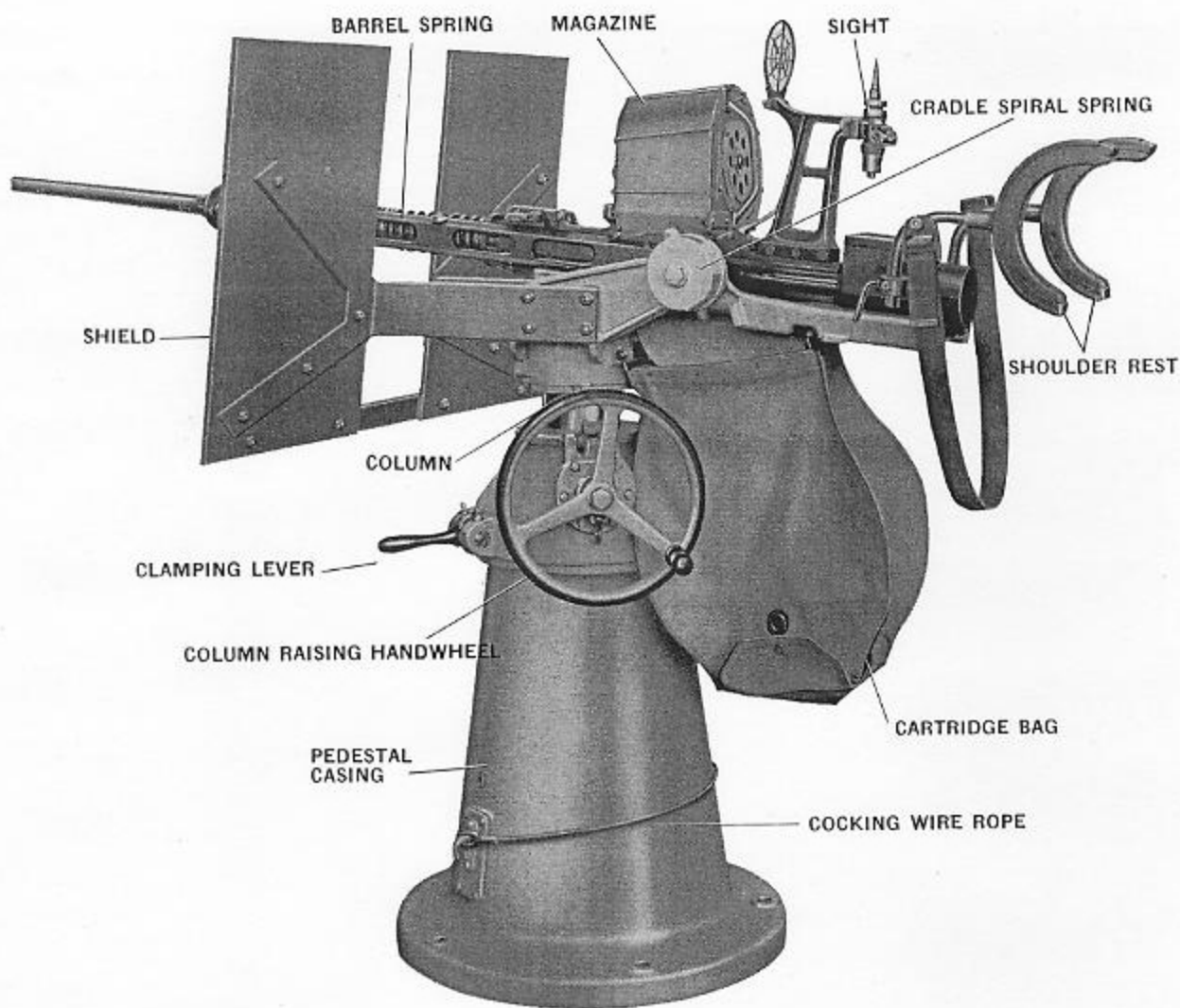

20 mm. A. A. Gun on Mark 4 Mod. 3 Mount

PREFACE

This Ordnance Pamphlet, No. 911, is a revision of the Gun Section of Ordnance Pamphlet No. 813 and describes the construction, operation, and maintenance of the 20 mm. A.A. Guns.

Additional Ordnance publications relating to the use of the 20 mm. A.A. Guns are:

- O.P. 909 —20 mm. Mounts Mark 2, Mark 2 Mod. 1, Mark 2 Mod. 2; Mark 4, Mark 4 Mod. 1, Mark 4 Mod. 2, Mark 4 Mod. 3; Mark 5, Mark 5 Mod. 1, Mark 5 Mod. 3, Mark 5 Mod. 4; Mark 6; Mark 10 and Mark 10 Mod. 1.
- O.P. 945 —20 mm. A.A. Range Tables.
- O.D. 4429 —Gun Sight Mark 14 Mod. 2—Installation and Operation.
- SK. No. 103308—20 mm. Machine Gun and Mount Index.
- Ordalt No. 1186—20 mm. Cradles Marks 2 and 4—Instructions for Necessary Modification for Assembly of Gun Sight Mark 14.
- Ordalt No. 1226—20 mm. Machine Gun Mechanism Marks 2 and 4—20 mm. Hand Grips and Shoulder Rests Marks 2 and 4—Instructions for Adding Drainage Holes.
- Ordalt No. 1269—20 mm. Cradle Mark 2 and Mark 2 Mod. 1.
20 mm. Cradle Mark 4 and Mark 4 Mod. 1—Instructions for Installation of Cocking Sheave.
- Ordalt No. 1300—20 mm. Shield Mark 2; 20 mm. Shield Mark 4—Instructions for Modification of Shield Brackets.
- Ordalt No. 1366—20 mm. Cradle Mark 2 and Mark 2 Mod. 1.
20 mm. Cradle Mark 4 and Mark 4 Mod. 1—Instructions for Cradle Modification to Facilitate Disassembly.
- Ordalt No. 1395—20 mm. Shields Marks 2 and 4—Improvement of Sight.
- Ordalt No. 1398—20 mm. Mounts Marks 2 and 4—Changes to Improve Lubrication.
- Ordalt No. 1457—Modification of 20 mm. Sight Mark 4 Mod. 1.

The Mark 1 Gun was the original type made in Switzerland. The Mark 2 is the improved version made in England and also being made in U. S. A. The Mark 4 Gun is almost identical with Mark 2 except for slightly different manufacturing limits. Both Marks 2 and 4 Guns will be found in service in the U. S. Navy, but eventually only the Mark 4 will be manufactured in this country.

INTERCHANGEABILITY

There is very little difference, from the operating point of view, between

Mark 2—British

Marks 2 and 4—U. S. N.

All of the above three Marks of assembled guns are interchangeable as units. There are certain differences in the Marks 2 and 4 guns that affect interchangeability of parts. When individual parts are not interchangeable between Marks 2 and 4, the assembly or the subassembly containing these parts is usually interchangeable.

AMMUNITION

The ammunition is common for Marks 1 and 2 (British) and Marks 2 and 4 (U. S. N.) Guns.

TABLE OF CONTENTS

NOTE—Plate 1 is the folded insert of the gun assembly at page 160.

	Text Page	Illus. Fig. No.
Frontispiece.....	2	
Preface.....	3	
Chapter 1		
DATA		
Gun Firing Rate.....	11	
Magazine Capacity.....	11	
Gun Barrel Data.....	11	
Range Data.....	11	
Weights of Components.....	12	
Chapter 2		
GENERAL DESCRIPTION OF GUN OPERATION		
Features.....	15	1
Principle of Construction.....	15	2
Firing Features.....	15	
Gun—Construction—General Description.....	15	Plate 1
Magazine—General Description.....	15	7
Mount.....	15	
Operating Features.....	17	3-4-5-6
Chapter 3		
GUN MECHANISM		
Trigger Mechanism.....	23	
Recoiling Mechanism.....	23	
Gun Barrel Nomenclature.....	23	9
Gun Barrel Construction.....	25	
Gun Barrel Replacement.....	25	10 and 12
Barrel Stop Pin.....	26	11
Barrel Locking Gear.....	26	8
Double Loading Stop.....	26	20 to 23
Breech Casing.....	27	
Gun Mounting Attachments.....	28	13
Magazine Catch Gear and Ejector.....	29	14 to 18
Ejector and Cartridge Ejection.....	32	19
Magazine Interlock Gear Operation.....	33	16-17
Hammer Plate Operation.....	34	44-45
Double Loading Stop Operation.....	34	20 to 23

TABLE OF CONTENTS

Chapter 4

TRIGGER MECHANISM

	Text Page	Illus. Fig. No.
Trigger Mechanism.....	39	24
Trigger Function.....	40	
Cocked Position.....	42	24-25
Firing Action.....	42	26 to 31
Safe/Fire Gear.....	47	32
Magazine Interlock Gear Function.....	48	
Magazine Interlock Gear Action.....	48	33 to 42
Magazine Interlock Withdrawal When Unshipping Magazine.....	52	

Chapter 5

RECOILING PARTS AND BUFFER

Components.....	57	43
Striker Gear.....	58	44-45
Breech Block.....	59	44-45
Breech Bars.....	59	43
Barrel Springs and Case.....	59	43
Recoil Buffer Springs.....	61	46
Trigger Buffer Springs.....	61	24

Chapter 6

MAGAZINE

Operation.....	65	47
Feed Action.....	65	47
Magazine Clock Spring.....	65	47
Cartridge Feeder.....	65	47
Spring Tension Limits.....	65	47
Loading.....	66	48 to 56
Completely Tensioning a Magazine Spring.....	70	58
Spring Tension Indicator.....	71	47
Slight Initial Tensioning of a Magazine Spring.....	71	58
Relieving the Magazine Spring Tension.....	72	59 to 61
Unloading a Fully Tensioned and Completely Filled Magazine.....	73	62
Unloading a Completely Filled Magazine Having Initial Spring Tensioning.....	73	63
Unloading a Fully Tensioned and Partly Filled Magazine.....	73	62
Stripping a Magazine.....	74	64 to 67
Reassembling a Stripped Magazine.....	77	
Changing Magazines.....	78	
Magazine Maintenance.....	78	
Magazine Corroded or Dry.....	78	
Magazine Clock Spring—Care of.....	78	
Magazine Interlock Bolt—Care of.....	78	35
Magazine Lubrication.....	78	

TABLE OF CONTENTS

Chapter 7

SIGHT

	Text Page	Illus. Fig. No.
Description.....	82	68-69
Use of Sights Mark 2, Mark 4, and Mark 4 Mod. 1.....	83	
Shipping and Unshipping the Sight—Mark 4 and Mark 4 Mod. 1.....	83	
Preparing Sight for Stowing—Mark 4 and Mark 4 Mod. 1.....	83	
Replacement of Foresight—Mark 2, Mark 4, and Mark 4 Mod. 1.....	85	
Mark 5 Sight—Description.....	85	69
Mark 5 Sight—Operation.....	85	
Mark 5 Sight—Servicing.....	87	70
Alternate Rear Sight Tips.....	87	
Bore Sighting.....	88	71-72

Chapter 8

SHOULDER REST

Marks 2 and 4 Shoulder Rest Assembly.....	96	
Mark 5 and Mark 5 Mod. 1 Shoulder Rest Assemblies.....	96	73
Vertical Adjustment.....	97	73
Lateral Adjustment.....	97	
Shoulder Pad Angular Adjustment.....	97	
Instructions for Use.....	97	74 to 77
Adjustment of Clamping Levers.....	101	

Chapter 9

AMMUNITION

Ammunition Types.....	104
Loaded and Fuzed Projectile with Tracer.....	104
Loaded and Fuzed Projectile without Tracer.....	104
Blind Loaded and Tracer Type Projectile.....	104
Blind Loaded and Plugged Projectile.....	104
Propellant.....	104
Ammunition Construction.....	105
High Explosive Shell.....	105
Ammunition Packing.....	105
Unpacking Cartridges.....	105
Inspection of Cartridges.....	105
Greasing Ammunition.....	105
Dropping Cartridges.....	106
Cartridge Bag.....	106
Naval Ammunition Depot.....	106

Chapter 10

GUN MAINTENANCE INSTRUCTIONS

Cleaning and Oiling of Gun.....	108
When to Clean and Oil.....	108
Lubricating Oil to be Used.....	108

TABLE OF CONTENTS

Chapter 10 (Contd.)

GUN MAINTENANCE INSTRUCTIONS	Text Page	Illus. Fig. No.
Double Loading Stop Parts Lubrication.....	108	78
Double Loading Stop Gear and Buffer Corrosion.....	108	78 and 80
Securing Bolt Lubrication.....	108	
Barrel and Barrel Spring—Care of.....	109	
Barrel Bore and Firing Chamber—Care of.....	109	
Muzzle Covers.....	110	
Stoppages—How to Clear.....	110	
Use of Cartridge Extracting Tool.....	110	79
Life of Barrel.....	111	
Gun Barrel Replacement.....	112	
Gun Barrel Removal.....	112	
Gun Barrel Installation.....	112	
Violent Recoils.....	112	
Buffer Corrosion.....	113	80
Gun Mounted on Submarine.....	114	
Cleaning.....	114	
Lubrication.....	114	
List of Gun Casualties.....	115	

Chapter 11

COCKING AND UNCOCKING THE GUN MECHANISM

Cocking Sheave Method—Mounts With Adjustable Trunnions.....	122	81-82
Cocking Sheave Method—Fixed Height Mounts.....	125	
Cocking Rope Method—Without Cocking Sheave.....	125	
Cocking Lanyard Mark 3.....	126	
Hook and Rope Cocking Tool Mark 4.....	126	
Block and Tackle Mark 2.....	126	83
Ratchet Type Cocking Tool Mark 1.....	127	84

Chapter 12

PARTIAL STRIPPING

(See Plate 1, Page 160)

Gun Tools.....	130	85
Breech Face Piece Removal.....	131	86-87
Breech Face Piece Installation.....	134	88
Barrel Spring Case and Cotter Securing Bolt and Retainer Removal.....	135	89 to 92
Barrel Spring Removal.....	137	
Hand Grip Removal.....	137	
Trigger Partial Stripping.....	137	101
Breech Block, Bolt and Sear Removal.....	138	101
Breech Face Piece Removal.....	138	87
Striker Gear Removal.....	138	95

TABLE OF CONTENTS

Chapter 12 (Contd.)		
PARTIAL STRIPPING		
	Text Page	Illus. Fig. No.
Barrel Assembly Removal.....	138	
Stripping the Gun Barrel Assembly.....	138	
Barrel Locking and Double Loading Stop Removal.....	138	
Buffer Removal.....	139	93
Ejector and Magazine Catch Removal.....	140	94
Inspection and Adjustment after Partial Stripping.....	142	
Striker Pin Protrusion.....	142	95
Hammer and Hammer Plate Wear.....	143	95
REASSEMBLING GUN		
Magazine Catch Lever and Ejector Reassembly.....	143	94
Barrel Locking Gear and Double Loading Stop Reassembly.....	143	96—Plate 1
Buffer Reassembly.....	144	93
Barrel Replacing.....	145	97-98
Striker Gear Reassembly.....	146	95
Breech Block, Bolt and Sear Reassembly.....	147	43 and 101
Trigger Hook Casing and Cover Plate Reassembly.....	147	101
Hand Grip Reassembly.....	147	Plate 1
Test of Operation before Further Reassembly.....	147	
Breech Bar and Barrel Spring Reassembly (Rectangular Wire Type).....	147	99
Breech Bar and Barrel Spring Reassembly (Round Wire Type).....	147	100
Chapter 13		
COMPLETE STRIPPING OF GUN		
Stripping (Continuation of Partial).....	151	
Trigger Casing Gear Removal.....	152	101-102
Parallelogram.....	152	101-102
Parallelogram Spring Box.....	152	101-102
Trigger Gear in Breech Casing Removal.....	152	101-102
Safe/Fire Gear Stripping.....	154	32
Magazine Catch and Interlock Gear Stripping.....	154	94
Trigger Pawl Tripping Bolt Stripping.....	154	Plate 1
Magazine Interlock Rod Guide Block Removal.....	154	Plate 1
Breech Pawl Removal.....	154	Plate 1
Hammer Plate Stripping.....	154	Plate 1
Hand Grips Retaining Catch.....	154	
Barrel Spring Seating Ring Retaining Catch Stripping.....	154	Plate 1
Breech Casing Barrel Stop Pin Stripping.....	155	Plate 1
Trigger Intermediate Lever Plunger Stripping.....	155	Plate 1
REASSEMBLING GUN		
Trigger Intermediate Lever Plunger Reassembly.....	156	Plate 1
Barrel Stop Pin in Breech Casing Reassembly.....	156	Plate 1
Barrel Spring Seating Ring Retaining Catch Reassembly.....	156	Plate 1
Hand Grip Retaining Catch Reassembly.....	156	Plate 1

TABLE OF CONTENTS

Chapter 13 (Contd.)		
REASSEMBLING GUN		
	Text Page	Illus. Fig. No.
Hammer Plate Reassembly	156	Plate 1
Breech Pawls Reassembly	156	Plate 1
Magazine Interlock Rod Guide Block	156	Plate 1
Trigger Pawl Tripping Bolt	156	
Magazine Interlock Fork	156	
Safe/Fire Gear Reassembly	157	Plate 1
Trigger Pawl, Pawl Holder, Trigger Crank	157	
Trigger Intermediate Lever	157	
Trigger and Trigger Hook	157	
Parallelogram	157	
Trigger Hook Holder and Buffer Spring	157	

PARTS LIST

Marks 2 and 4

Instructions for Ordering Replacement Parts	161
Gun Barrel	163
Gun Mechanism	164
Shoulder Rest	178
Sight	188
Magazine	197
Gun Tools and Accessories	204
Cocking Tools	208
Cross Index to OE and Bureau of Ordnance Numbers	215

Chapter 1

GUN

Firing Rate.....450 Rounds per Minute

MAGAZINE

Capacity.....60 Rounds

GUN BARREL

Weight—Ribbed.....37 Pounds

—Solid.....46 Pounds

Length.....4 Feet, 9 $\frac{1}{4}$ Inches

Caliber.....".7898 (Approx. 20 mm.)

Number of Grooves.....9

Twist of Rifling.....Right Hand, 1 turn in 36 Cal.

Locked by.....Rotate 60 Degrees and rotate locking lever into slot in barrel

Barrel Spring Compression (breech block in extreme forward position)

Rectangular Wire.....72 Pounds

Round Wire.....130 Pounds

Barrel Spring Compression (metal to metal contact between barrel spring case and buffer)

Rectangular Wire.....535 Pounds

Round Wire.....374 Pounds

Barrel Spring Compression, Full Recoil (metal to metal contact between buffer and breech casing)

Rectangular Wire.....576 Pounds

Round Wire.....396 Pounds

Buffer Spring Compression, 12 Springs, Full Recoil (metal to metal contact between buffer and breech casing)

Rectangular Wire.....2508 Pounds

Round Wire.....2220 Pounds

Total Compression Barrel Spring and Buffer Springs, Full Recoil (metal to metal contact between buffer and breech casing)

Rectangular Wire (Barrel and Buffer Springs).....3084 Pounds

Round Wire (Barrel and Buffer Springs).....2616 Pounds

RANGE

Maximum at 45 Degrees Elevation.....Approx. 4800 Yds.

DATA-MARK 2 AND MARK 4

WEIGHTS

Gun Barrel and Mechanism (Ribbed Barrel)	141 Pounds
Gun Barrel and Mechanism (Solid Barrel)	150 Pounds
Sight—Marks 2, 4, and 4 Mod. 1	13 Pounds
Sight—Mark 5	7 Pounds
Shoulder Rest—Marks 2 and 4	20 Pounds
Shoulder Rest—Mark 5	28 Pounds
Shoulder Rest—Mark 5 Mod. 1	25 Pounds
Magazine—Marks 2 and 4—Loaded	63 Pounds
Magazine—Marks 2 and 4—Unloaded	31 Pounds

NOTES

COMPONENT PARTS

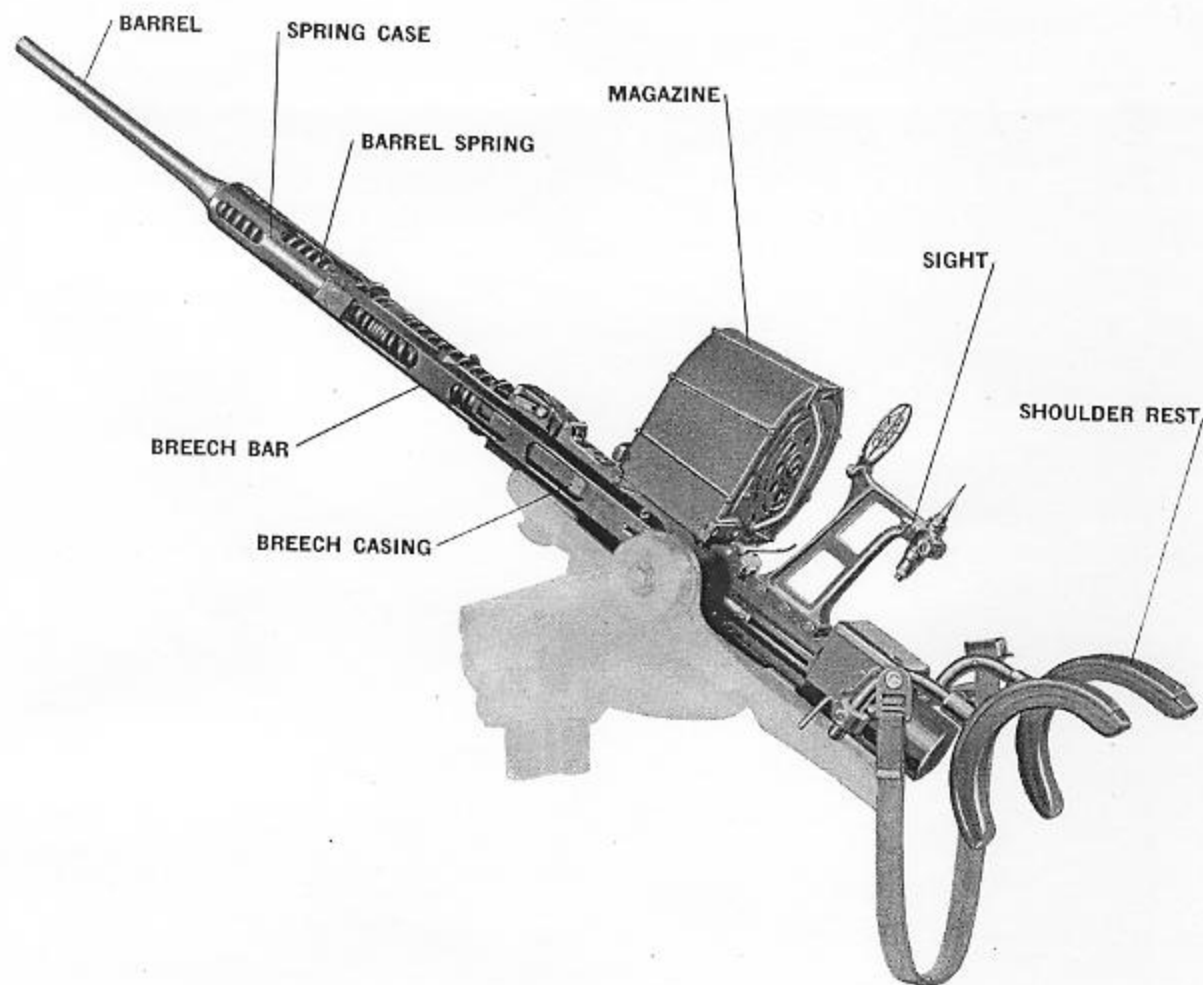

Figure 1—Exterior view showing general arrangement of the Mark 4, 20 mm. A. A. Gun

Chapter 2

GENERAL DESCRIPTION OF GUN OPERATION

FEATURES

The Marks 2 and 4 Gun Mechanisms, as stated in the "Preface" on page 3, operate the same. They are for close range, high angle fire as an antiaircraft defense. Each is singly mounted upon a pedestal and is capable of being trained through 360 degrees. The elevation limits on the guns mounted on Mark 2, Mark 4, and Mark 5 Mounts are from 5 degrees below horizontal to 87 degrees above horizontal except on Mark 4 Mod. 3 on which elevation is 90 degrees. Those mounted on Mark 6 and Mark 10 Mounts have elevation limits from 15 degrees below horizontal to 90 degrees above horizontal.

PRINCIPLE OF CONSTRUCTION

The major difference between this gun and others is that the force of the explosion is absorbed in checking and reversing the forward movement of a relatively heavy bolt, or breech block, that is never locked. In most guns the force of the explosion is taken by the locked breech block and by the recoil cylinders and mechanism. See Figure 2.

FIRING

The gun fires automatically as long as the trigger is pressed and there is ammunition in the magazine. When the last round of each magazine is loaded into the gun and fired, the trigger mechanism is returned automatically to the cocked position regardless of the position of the trigger. This feature prevents the breech block mass from counterrecoiling on an empty gun after the last round is fired and, because there is no explosion to reverse the breech block, a recocking by hand would be necessary before firing could be continued. A Safe/Fire lever is fitted close to the right hand grip. See Figure 32. The rate of fire is approximately 450 rounds per minute.

The magazine is easily and quickly changed. It is retained by lugs on its fore end and a magazine catch at the rear. See Figure 18.

GUN

The gun is considered to consist of the following three units. See Figure 1.

1. The gun barrel
2. The machine gun mechanism
3. The shoulder rest and hand grips

The sight and magazine are considered as supplementary units required to complete the assembly.

MAGAZINE

The ammunition is supplied from a magazine that holds 60 rounds. The magazine is detachably mounted on the gun. It is filled, also serviced while removed from gun.

MOUNT

The mount includes the cradle in which the gun is fixed, the carriage which carries the oscillating parts, and the stand which is bolted to the deck. For complete information on mounts, see Ordnance Pamphlet No. 909.

COMPONENT PARTS

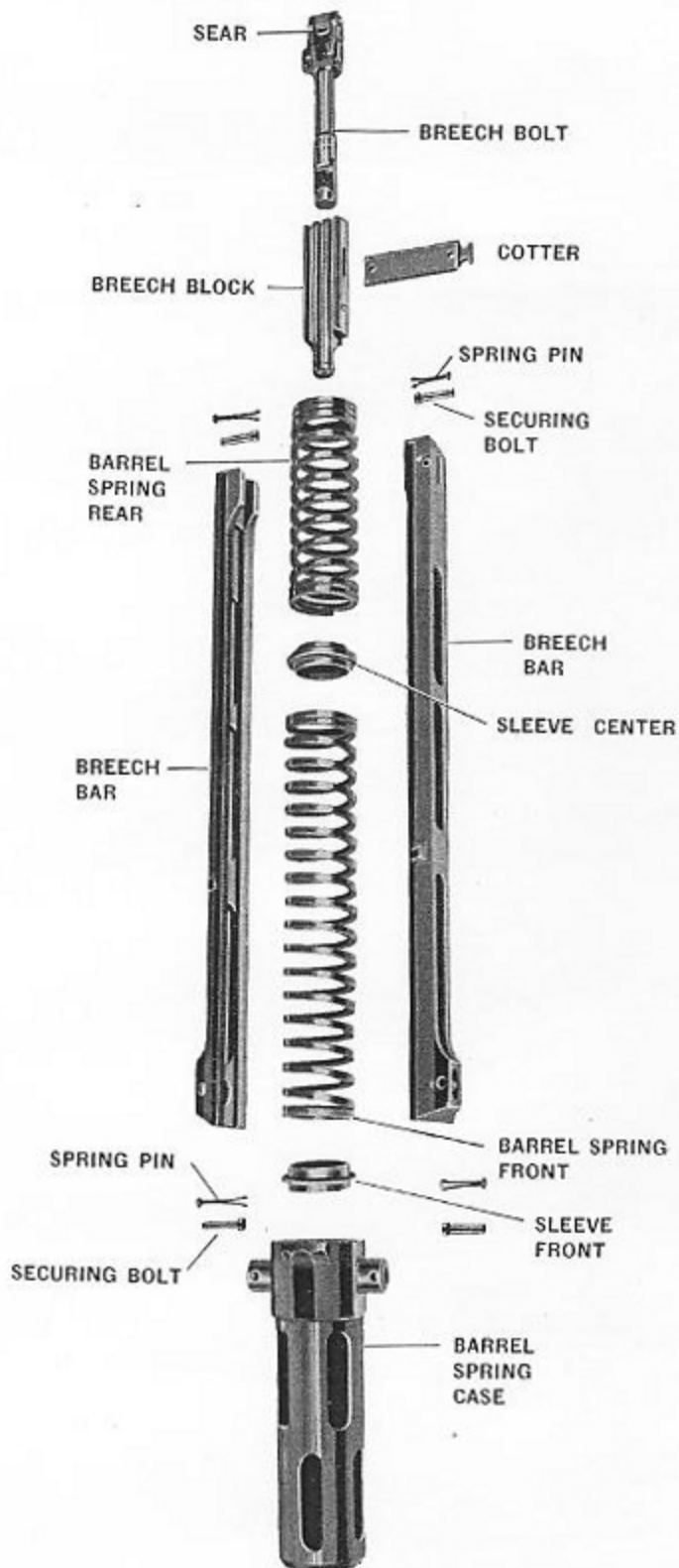

Figure 2—Recoiling Parts

OPERATING FEATURES

The more important features of the operating principle of the Mark 2 and Mark 4, 20 mm. A.A. Guns are as follows:

- (A). The breech casing and barrel do not recoil.
- (B). The recoiling parts are the breech block and the parts that connect it to a powerful two-piece barrel spring. See Figure 2. The breech block recoils and counterrecoils with a purely reciprocating action.
- (C). The barrel spring is the only force tending to keep the breech block closed. There is no positive lock.

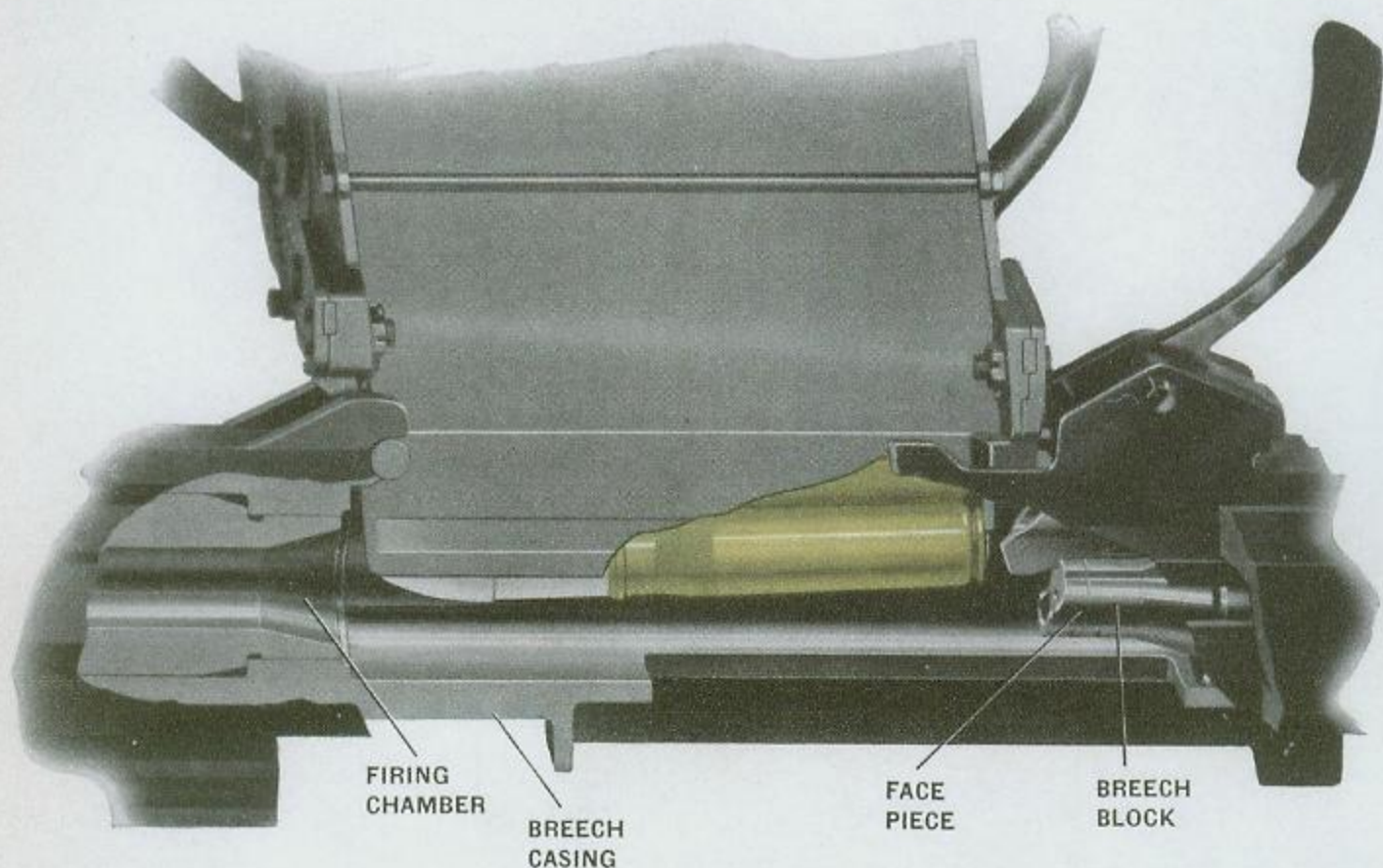

Figure 3—Loading Mechanism in cocked position. Breech block in position to pick up cartridge when trigger is released

(D). Preparatory to opening fire, the breech block must be pulled back, see Figure 3 and gun assembly Plate 1, until, the sear (OE-1317) is held by the trigger hook (OE-1216). This compresses the barrel springs (OE-1320 and 1321) and causes a pull on the recoiling parts being held in the cocked position by the trigger hook.

(E). Pressing the trigger releases the breech block allowing it to move forward, under the pull of the barrel spring.

(F). A round of ammunition is picked up from the magazine by the breech block on its way forward and is carried toward the gun barrel. At a point about half way forward, the next round in the magazine forces the cartridge down into the lip of the breech face piece as shown in Figure 4.

OPERATING FEATURES

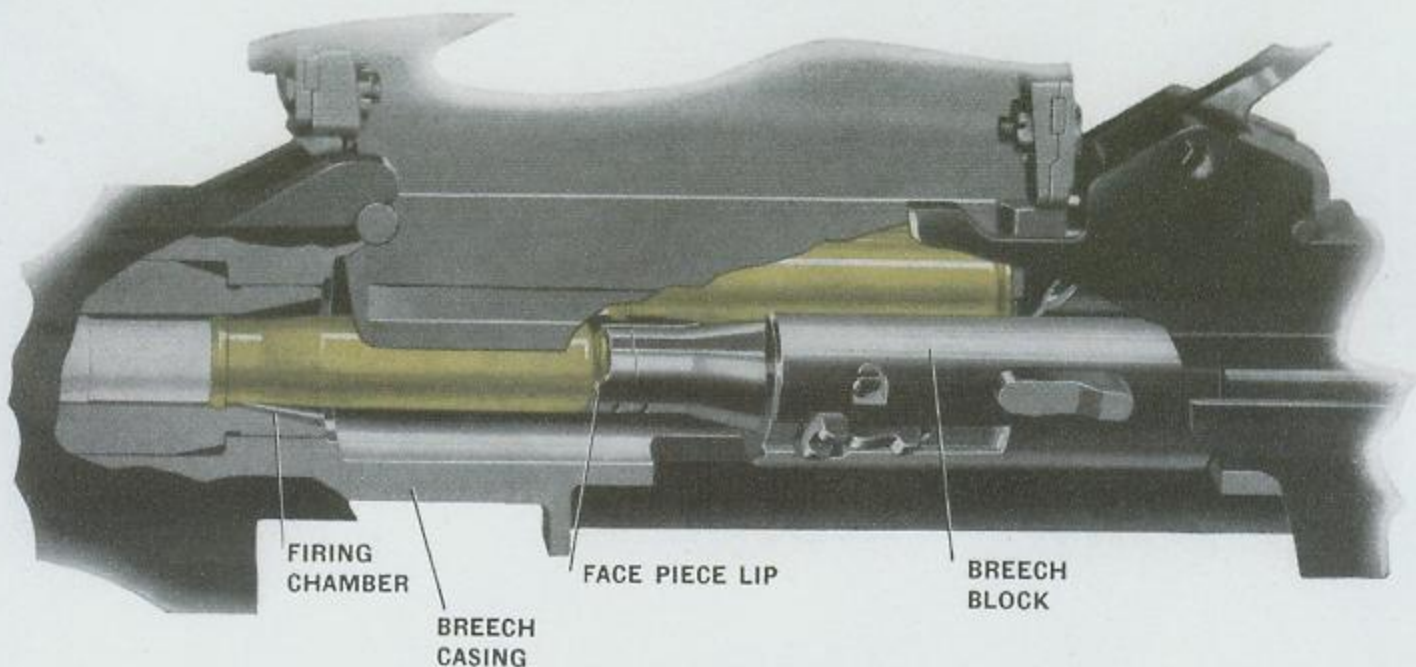

Figure 4—Operation of Loading Mechanism about half way of forward stroke

(G). Just before the breech block reaches the fully forward position, a striker pin in the breech block is operated by a hammer in the breech block and fires the round. A hammer plate in the breech casing operates the hammer as the breech block travels on recoil and counterrecoil inside the breech casing. Figure 5.

(H). When the round fires, the gas pressure first absorbs the forward momentum of the breech block and then blows the latter backward, thereby compressing the barrel spring which absorbs the rearward momentum imparted to the breech block by the gas pressure. The breech block is blown backward until at full recoil, it is to the rear of the position at which the trigger hook catches it. See Figure 31.

(I). As each round fires, the empty cartridge case together with the breech block is blown back from the chamber by the gas pressure. Subsequently the empty case is tipped out of the breech face piece by striking against an ejector in the breech casing. See Figure 6. The next round in the magazine is forcing the empty cartridge downward.

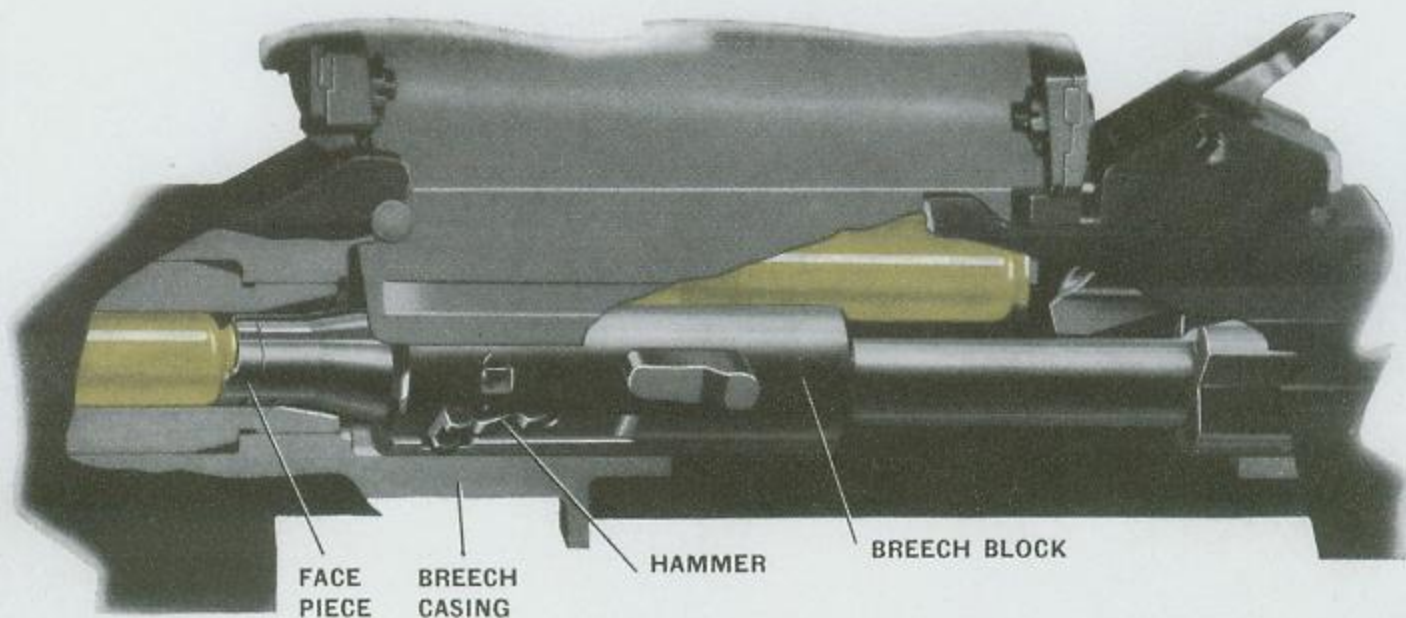
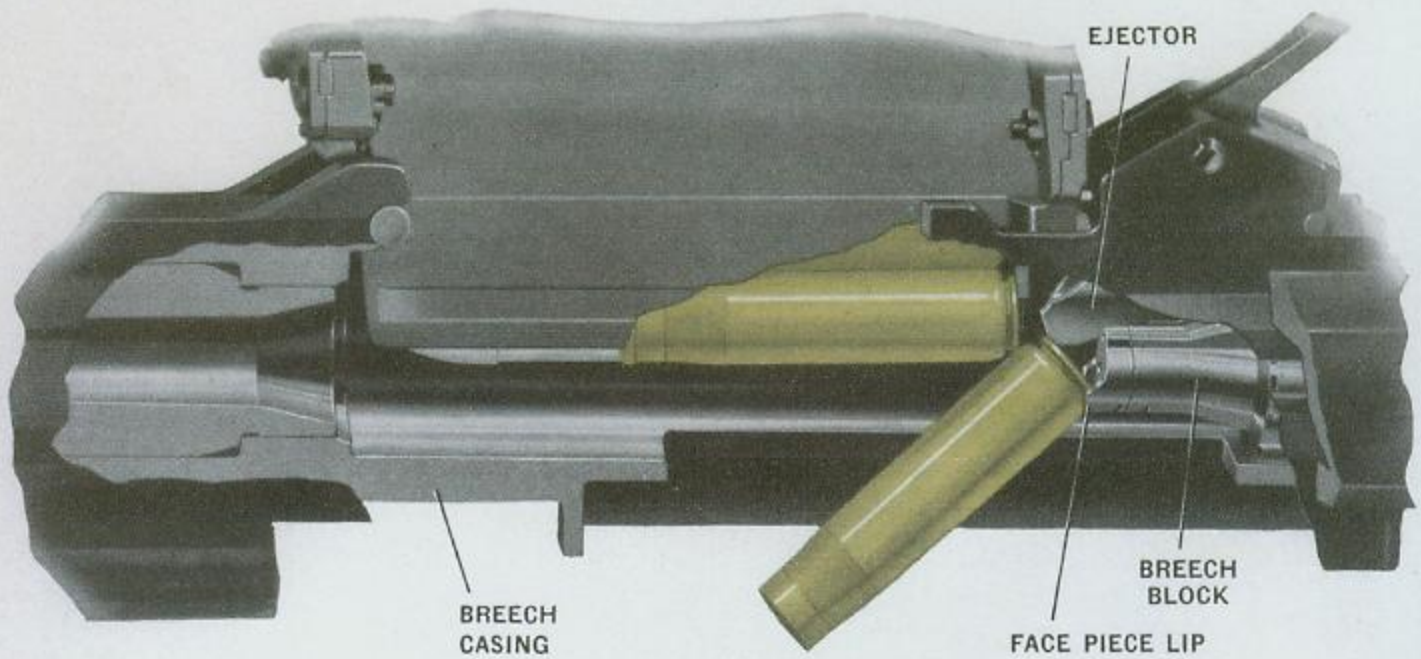

Figure 5—Cartridge Fired



**Figure 6—Breech Block returning to cocked position
Empty cartridge being ejected**

(J). When all the rearward momentum has been absorbed by the barrel spring, the counterrecoil of the barrel spring forces the breech block forward again. On its way, the breech block picks up the next round from the magazine and the firing sequence is continued as long as the trigger is kept pressed or until the magazine is emptied.

(K). Whenever pressure on the trigger is released, the breech block is caught on the next attempt to commence its counterrecoil and is held in the cocked position. See Figure 3. This happens in all cases when there is ammunition in the magazine. In case the pressure on the trigger is maintained and the magazine becomes empty then the trigger mechanism is returned automatically to the cocked position regardless of the position of the trigger. See Figure 24.

(L). The magazine, see Figure 7, consists of a cylindrical drum containing a clock spring that forces a cartridge feed block around a spiral in the magazine forcing the rounds down into the magazine mouth, where they are picked up by the breech block as it counterrecoils. A detailed description of the magazine action is given on Page 65.

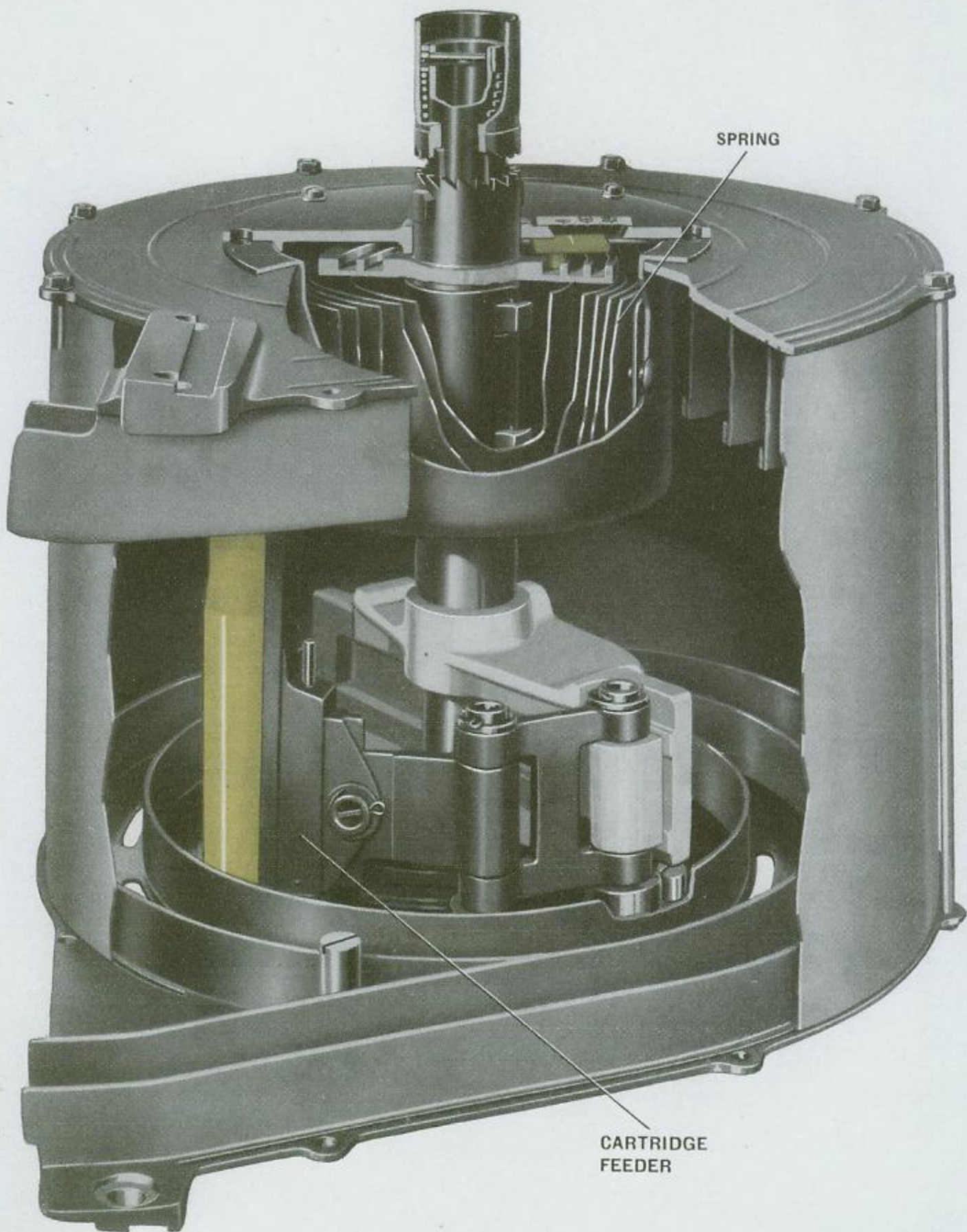

Figure 7—Magazine

NOTES

NOTES

GUN MECHANISM

Chapter 3

The following description covers the barrel and its breech casing with the various stops and locking devices mounted on it.

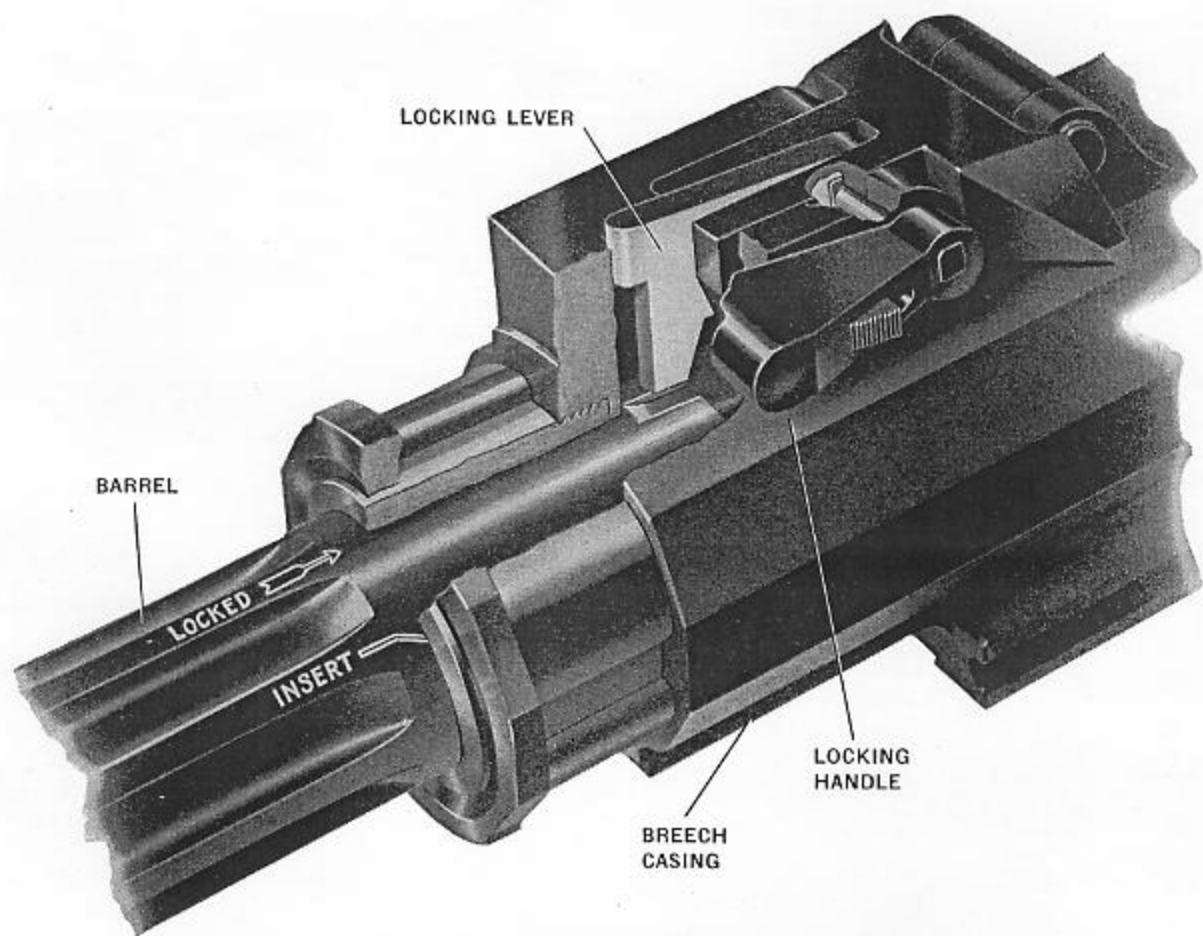

Figure 8—Barrel Locking Gear

TRIGGER MECHANISM

The trigger mechanism is mounted in a casing of its own and is described on Pages 39 to 53.

RECOILING MECHANISM

Recoiling Mechanism is covered in detail on Pages 57 to 61.

GUN BARREL NOMENCLATURE

To provide a standard by which the various sections and make-up of the barrel of the 20 mm. A.A. Gun may be described in correspondence or discussion the proper nomenclature is illustrated in Figure 9.

A similar drawing has been given wide distribution among the various agencies and personnel dealing with this subject so that a clearer picture in the discussion of this part may obtain.

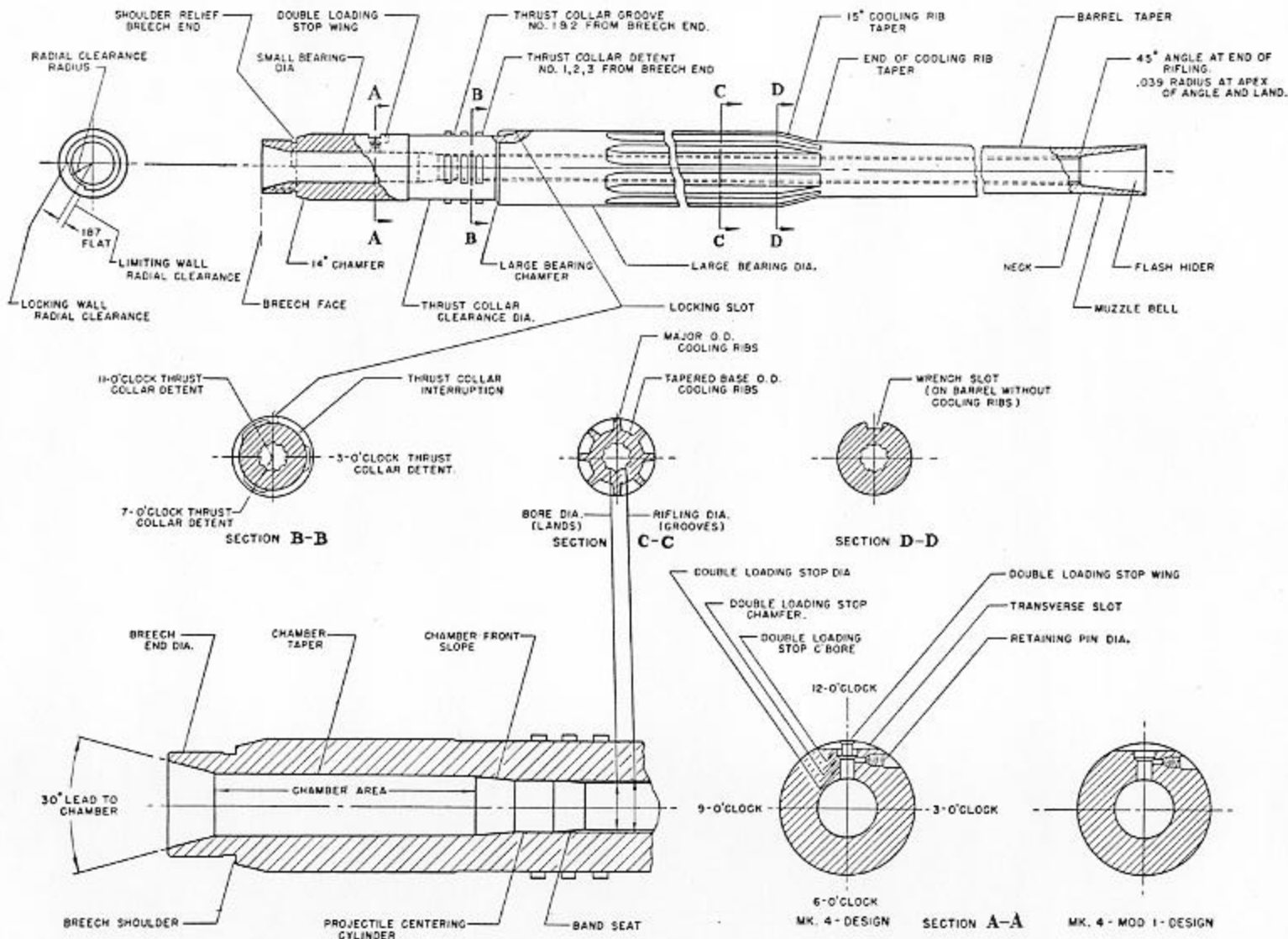

Figure 9—Gun Barrel Nomenclature

GUN MECHANISM

GUN BARREL

The gun barrel, Figure 9, is a forged steel piece 4 feet $9\frac{1}{4}$ inches long, bored out to a caliber of .7898 or approximately 20 mm. In the rifled section of the bore there are nine grooves with a right hand twist of one turn in a length of 36 calibers.

The following types of gun barrels have been issued to the service, all of which are interchangeable in either Mark 2 or Mark 4 Machine Gun Mechanisms:

Barrel Designation	Cooling Ribs	Stop Plunger—Lower
Mark 2	Yes	Keyhole Head
Mark 3	Optional	Keyhole Head
Mark 4	Optional	Keyhole Head
Mark 4 Mod. 1	Optional	Round Head

Some Mark 4 gun barrels without cooling ribs were issued to service labeled Mark 4 Mod. 1.

The first two inches of the barrel, known as the muzzle bell, has a flare which serves as a flasher hider.

GUN BARREL REPLACEMENT

The gun barrel is provided with three interrupted thrust collar detents located near the rear end, which engage in three corresponding grooves in the breech casing, see Figure 10, and lock the barrel in place. The barrel is further prevented from rotating in the breech casing and accidentally unlocking by the "Barrel Locking Gear" described on Page 26.

The barrel can be easily removed and a new one installed without stripping of any other parts.

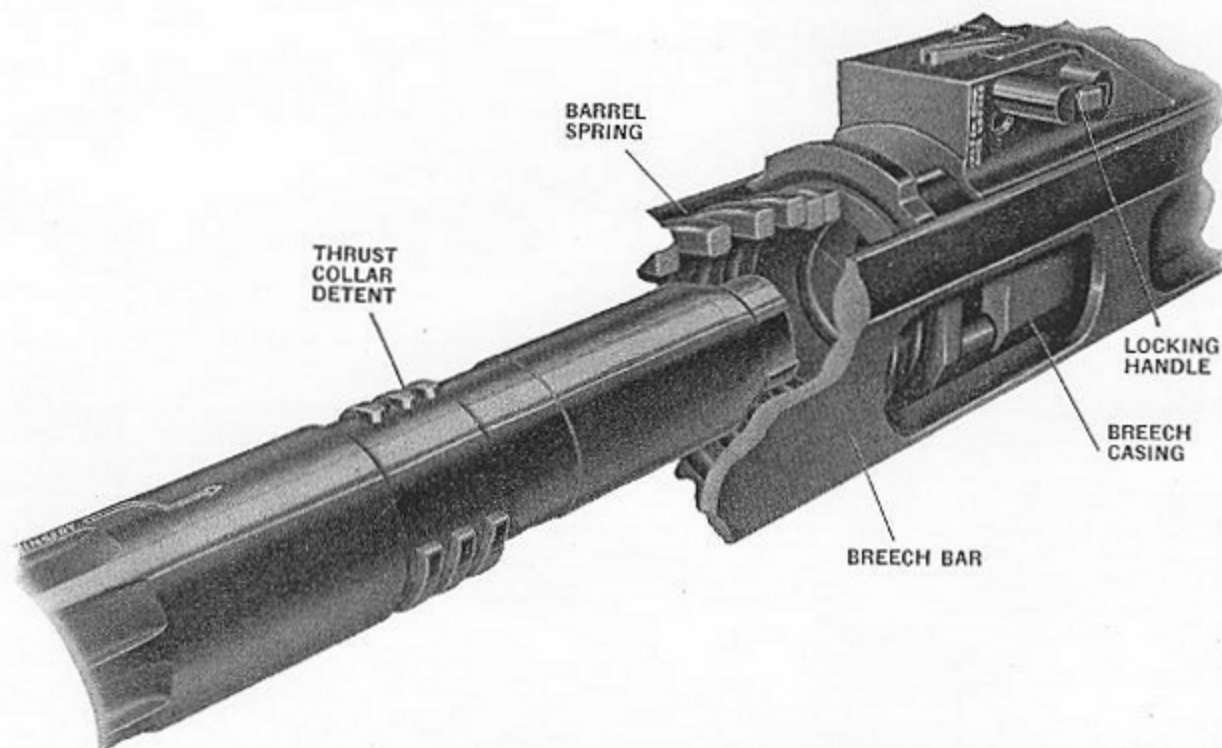

Figure 10—Gun Barrel ready for installation

BARREL STOP PIN

A stop pin is assembled in the left side of the breech casing and engages in an external slot in the rear end of the barrel. See Figure 11.

When inserting the barrel and rotating it into place, the stop pin positions the barrel so that the locking lever can be engaged in its slot in the barrel by moving the handle to the position marked "Locked".

This stop pin also serves to limit the rotation of the barrel in the opposite direction, so that the thrust collar detents are clear of the grooves in the breech casing and permit withdrawal of the barrel.

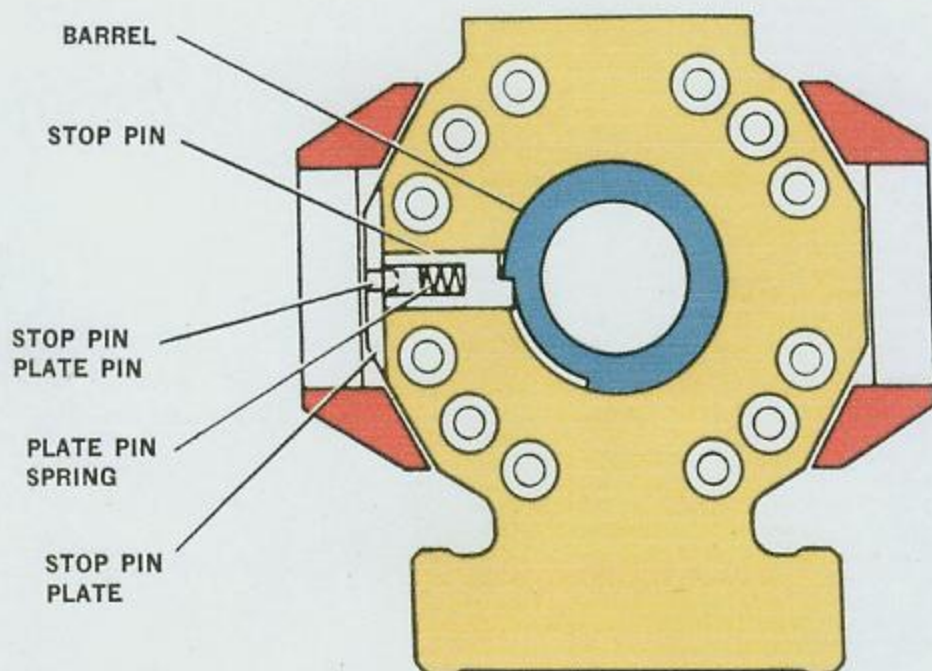

Figure 11—Barrel Stop Pin

BARREL LOCKING GEAR

The barrel locking gear (shown in Figure 12 and Section J-J of gun assembly Plate 1) consists of three parts:

1. Barrel locking handle pinned to—
2. An axis bolt (upon which the double loading stop is free to rotate).
3. Barrel locking lever, attached to the axis bolt.

The purpose of the barrel locking gear is to prevent the barrel from rotating and thereby freeing itself from the interrupted thrust collars, during the firing of the gun.

The barrel locking handle carries a catch lever that moves a plunger, holding the barrel locking handle in either of two positions, "LOCKED" or "UNLOCKED." When the catch lever is pressed in toward the breech casing and the handle is moved from "UNLOCKED" to "LOCKED", the axis bolt is turned, thereby rotating the barrel locking lever into a slot in the barrel. This locks the barrel so that it cannot rotate about its own axis.

DOUBLE LOADING STOP

The double loading stop prevents loading a round of ammunition into the barrel unless the chamber

is already clear at the double loading stop lower plunger. This plunger operates in a hole in the top wall of the chamber of the barrel. The operation of the double loading stop is illustrated and described more completely on page 34.

BREECH CASING

The breech casing, Figure 12, is a steel forging, bored out longitudinally and its principal functions are to:

1. Carry the barrel at its front end.
2. Carry the trigger group at its rear end.
3. Act as a guideway for the reciprocating breech block.
4. Carry the magazine on its top.
5. Attach to the mount.

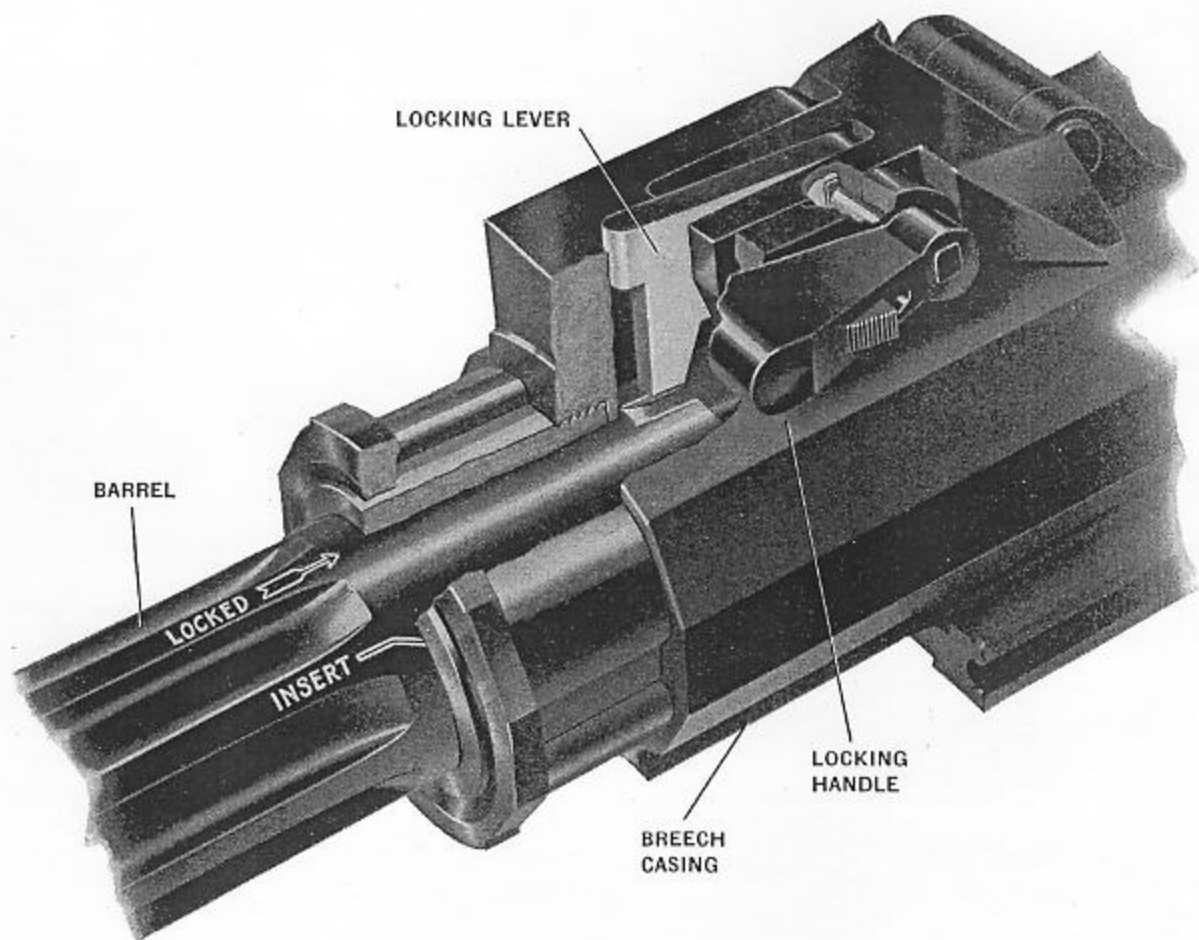

Figure 12—Gun Barrel installed ready to be locked in breech casing

GUN MECHANISM

GUN MOUNTING ATTACHMENTS

The gun is secured to the cradle of the mount by:

1. Two shoes that are a part of the breech casing (located at the front and rear) and fit into keyways in the cradle, Figure 13.
2. A gun securing bolt in the cradle which enters into a corresponding recess in the front shoe of the casing and takes the main fore and aft thrust on firing, Figure 13.

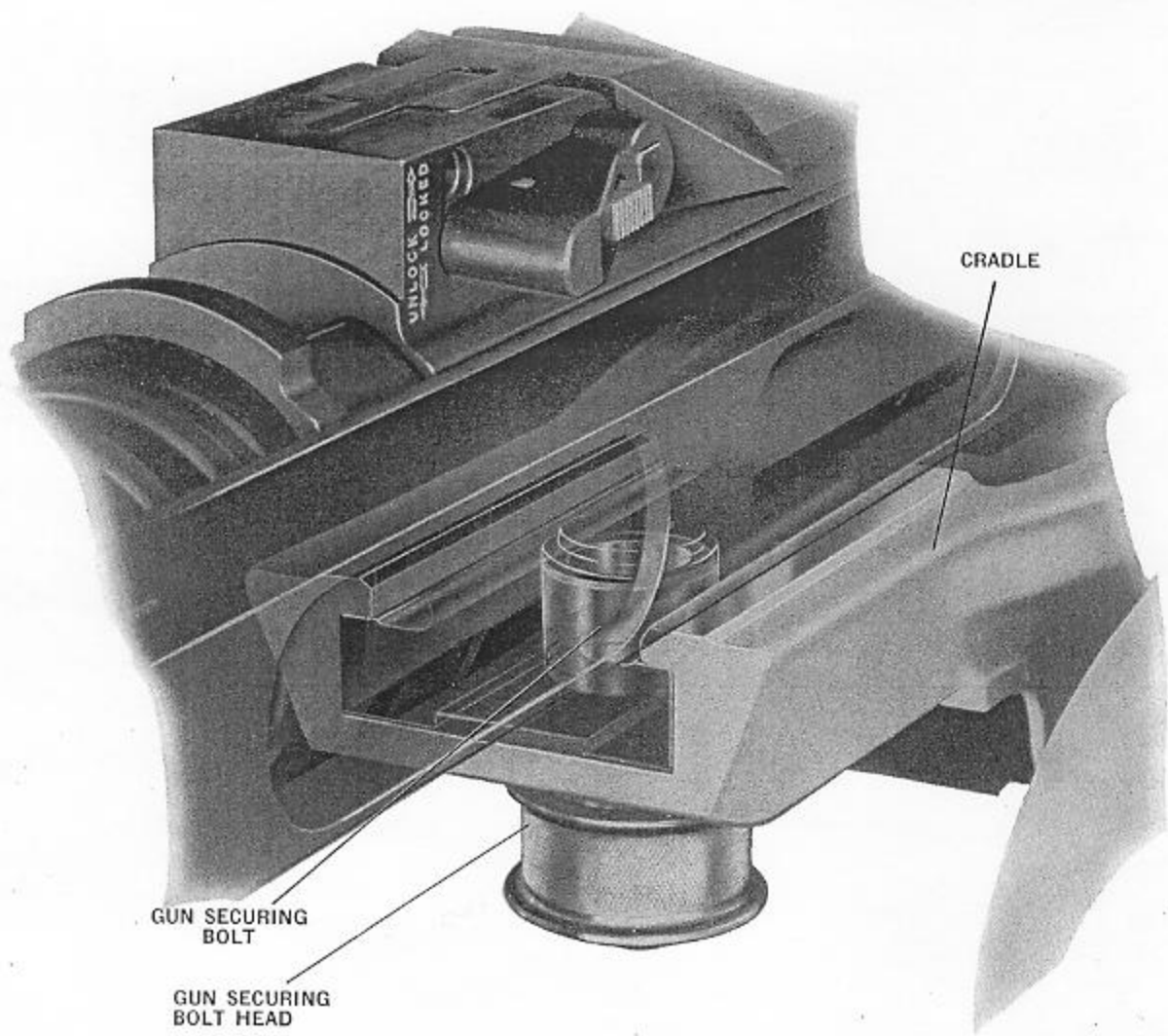

Figure 13—Gun Mounting Attachments

MAGAZINE CATCH GEAR AND EJECTOR

Magazine Catch Gear and Ejector, Figure 14, is mounted in the breech casing and consists of three sections:

1. Catch gear to retain the magazine in position.

2. Ejector.

3. Front portion of the magazine interlock gear, as shown in Figure 14. See Page 48 for details of trigger gear operation caused by interlock rod.

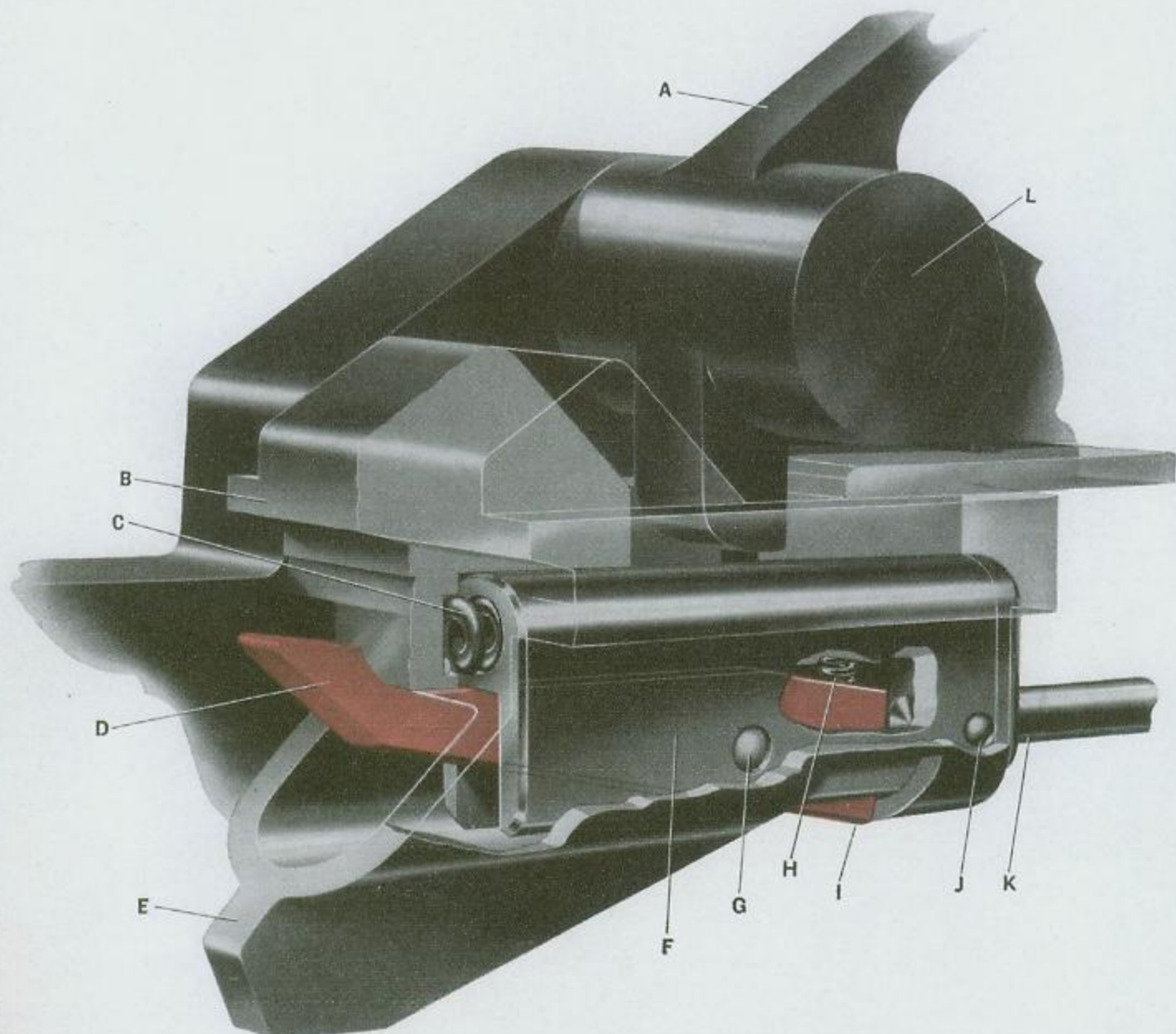

Figure 14—Magazine Interlock Gear in firing position

A—Magazine catch lever (OE-1043)
B—Magazine securing lug on ejector
C—Interlock carrier spring (OE-1340)
D—Interlock lever (OE-1074)
E—Ejector (OE-1045)
F—Interlock carrier (OE-1066)
G—Axis bolt (OE-1067) holding interlock lever to interlock carrier

H—Magazine interlock lever spring (OE-1330)
I—Magazine interlock lever in catch recess in ejector
J—Axis pin (OE-1261) holding interlock rod to interlock carrier
K—Interlock rod (OE-1075)
L—Magazine catch lever spring axis bolt (OE-1076)

The magazine catch gear is operated by a magazine catch lever (A), Figure 14, rotating on an axis bolt (L) mounted on the breech casing. The front toe (N), Figure 15, on the lever engages with a face on the ejector (E). The rear toe (M) on this lever engages with the upper rear end of the ejector. The ejector (E) is free to move slightly in a longitudinal direction and, therefore, can be moved rearward by rotating the magazine catch lever (A) toward the muzzle.

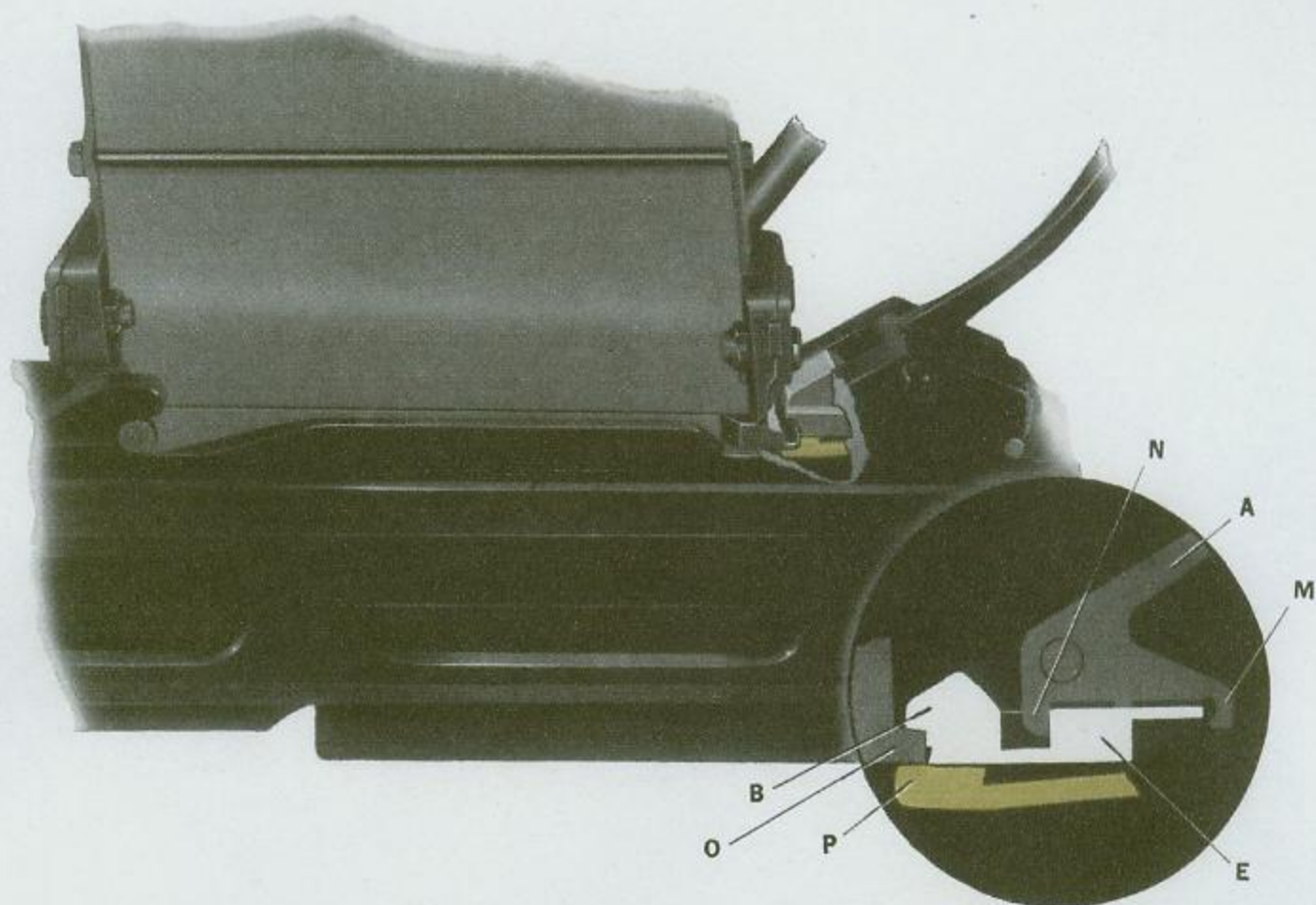

Figure 15—Magazine in shipped or firing position, showing catch down and ejector locking magazine in place

A—Magazine catch lever (OE-1043)
B—Securing lug on ejector for magazine
E—Ejector (OE-1045)
M—Rear toe of magazine catch lever

N—Front toe of magazine catch lever
O—Lug on magazine for locking by ejector
P—Magazine catch (OE-1046)

The ejector normally tends to move forward because of the pressure of the magazine catch spring, Figure 16. However, the ejector can be held cocked to the rear by the magazine catch (P), Figure 18. The magazine catch is pivoted at the rear and is able to rise in front. The magazine catch spring in addition to forcing the ejector forward, tends to force the catch into engagement with the front end of the ejector, as shown in Figure 18.

On the front end at the top of the ejector is a lug (B), Figure 15, that engages a corresponding lug (O) on the magazine and holds the magazine to the gun. See Figure 15. If the ejector is held cocked to the rear by the catch, the lug is clear of the magazine so that the latter can be shipped or unshipped. See Figures 17 and 18. As above mentioned, the ejector can be moved rearward to the cocked position by rotating the magazine catch lever toward the muzzle.

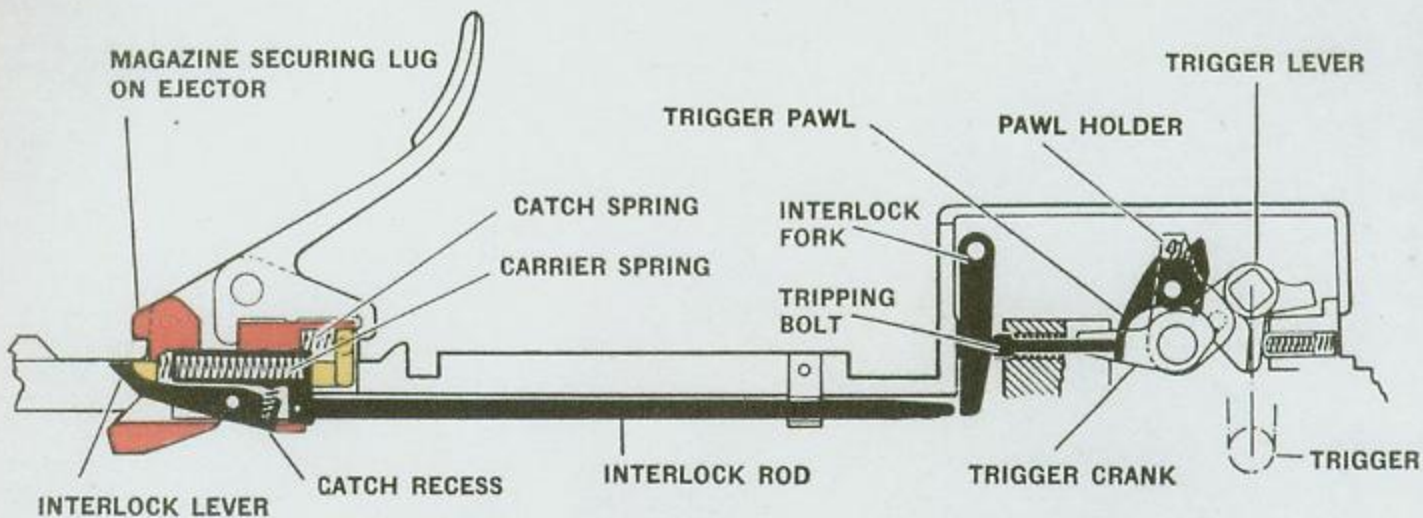

Figure 16—Magazine interlock gear in firing position

When the magazine is shipped, the ejector is moved forward automatically into position for locking the magazine. A projection on the magazine pushes down the front ends of the catch, disengaging it and allowing the ejector to move forward under the influence of the catch spring, into position to lock the magazine.

The catch may be disengaged without the necessity of shipping a magazine by pressing down the forward ends of the catch, using any suitable tool. The forward ends of the catch are visible in Figure 18.

CAUTION—When shipping a magazine the catch gear must be in the cocked position. The cocked position is shown in Figure 18, the magazine securing lug on the ejector being back of the front end of the catch. **NO ATTEMPT SHOULD BE MADE TO COCK THE GEAR BY FORCING A MAGAZINE PAST THE LUG.**

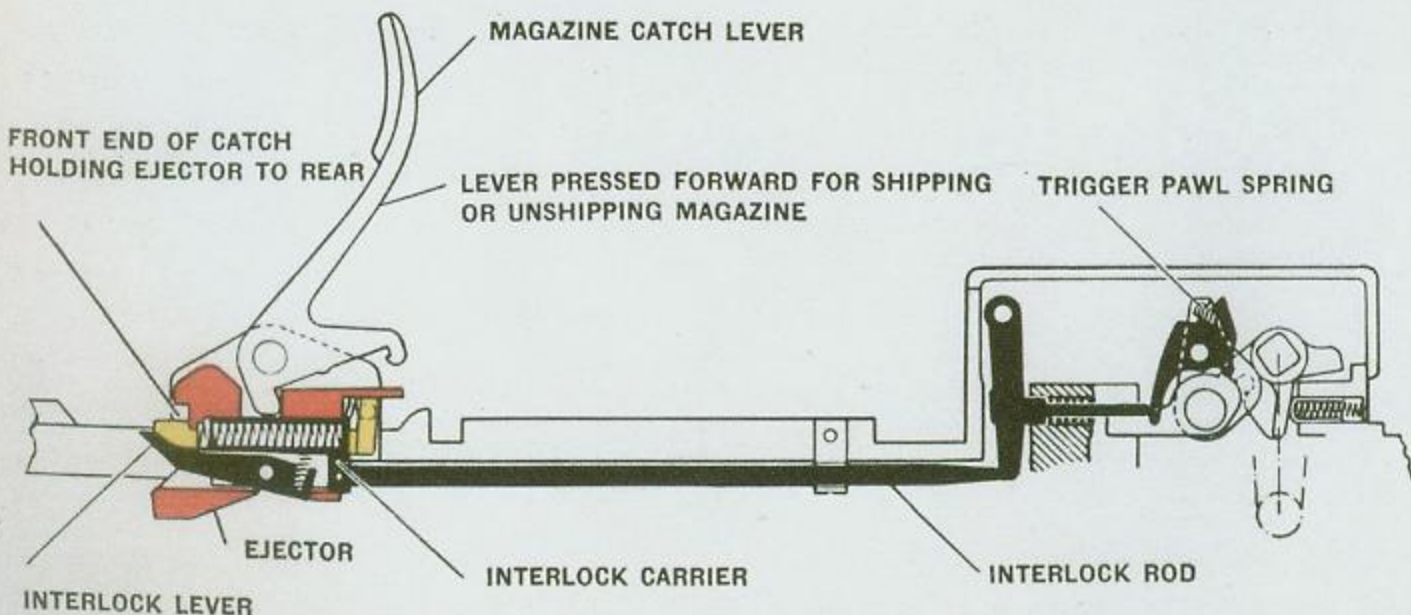

Figure 17—Magazine catch gear and ejector in position for shipping or unshipping magazine

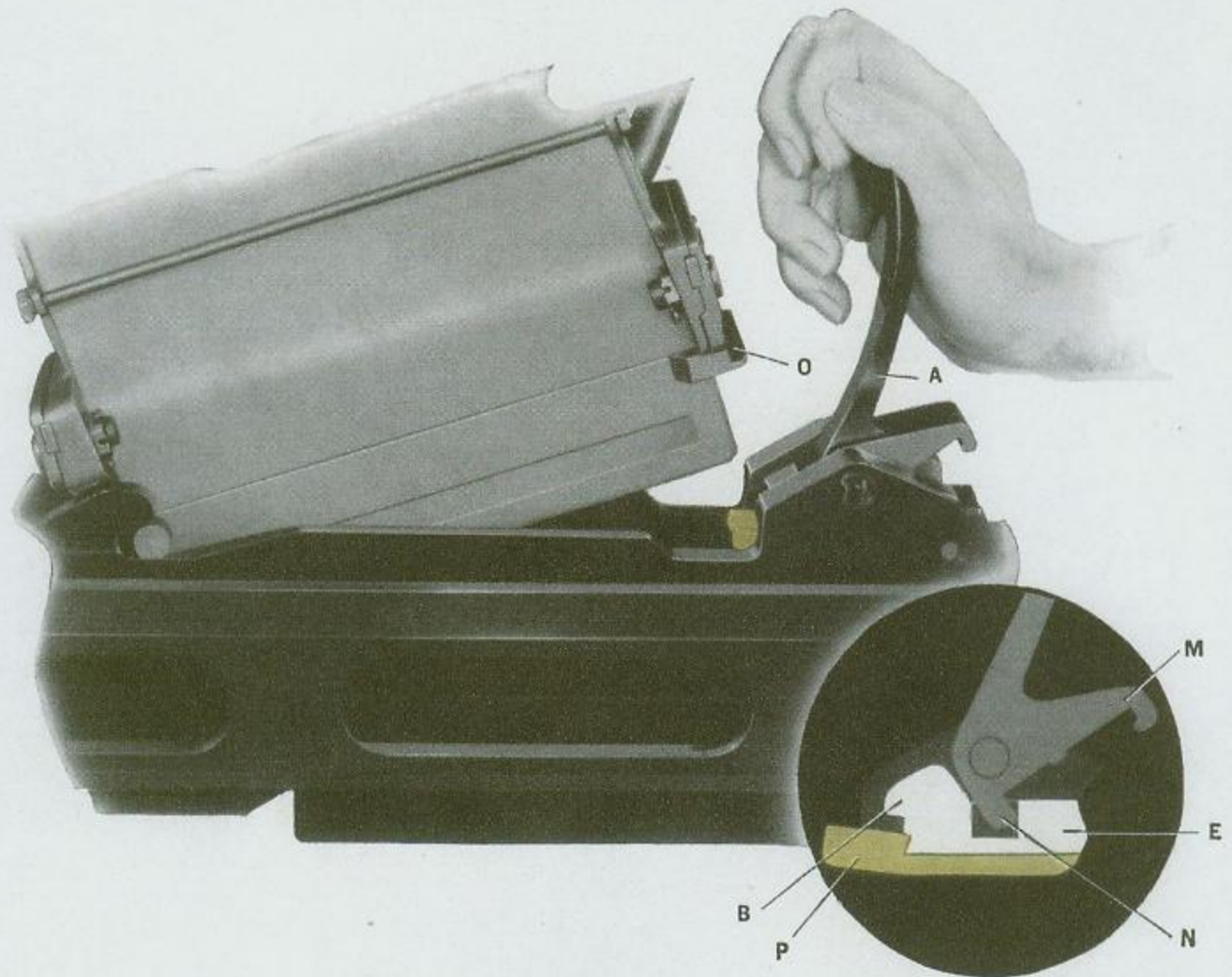

Figure 18—Unshipping a magazine—ejector moved to rear by hand pressure on catch lever and held to rear by catch

A—Magazine catch lever (OE-1043)
 B—Securing lug on ejector for magazine
 E—Ejector (OE-1045)
 M—Rear toe of magazine catch lever

N—Front toe of magazine catch lever
 O—Lug on magazine for locking by ejector
 P—Magazine catch (OE-1046)

EJECTOR AND CARTRIDGE EJECTION

The ejector serves as a magazine catch as described in "Magazine Catch Gear and Ejector," page 29, and also performs its main function of ejecting fired cartridge cases by means of its front lower toe. See Figure 19. This toe engages in a groove in the top of the breech block and this groove is continued through the breech block face piece.

The breech block recoils to the rear, carrying a fired case in the lip of the face piece and, as it passes the ejector, the rear of the case strikes against the toe of the ejector. The fired case is thus tipped forward, also downward as shown in Figure 19 and is forced out of the lip of the face piece. This action occurs with a violence sufficient to eject the empty cartridge case down and through an opening cut in the bottom of the casing.

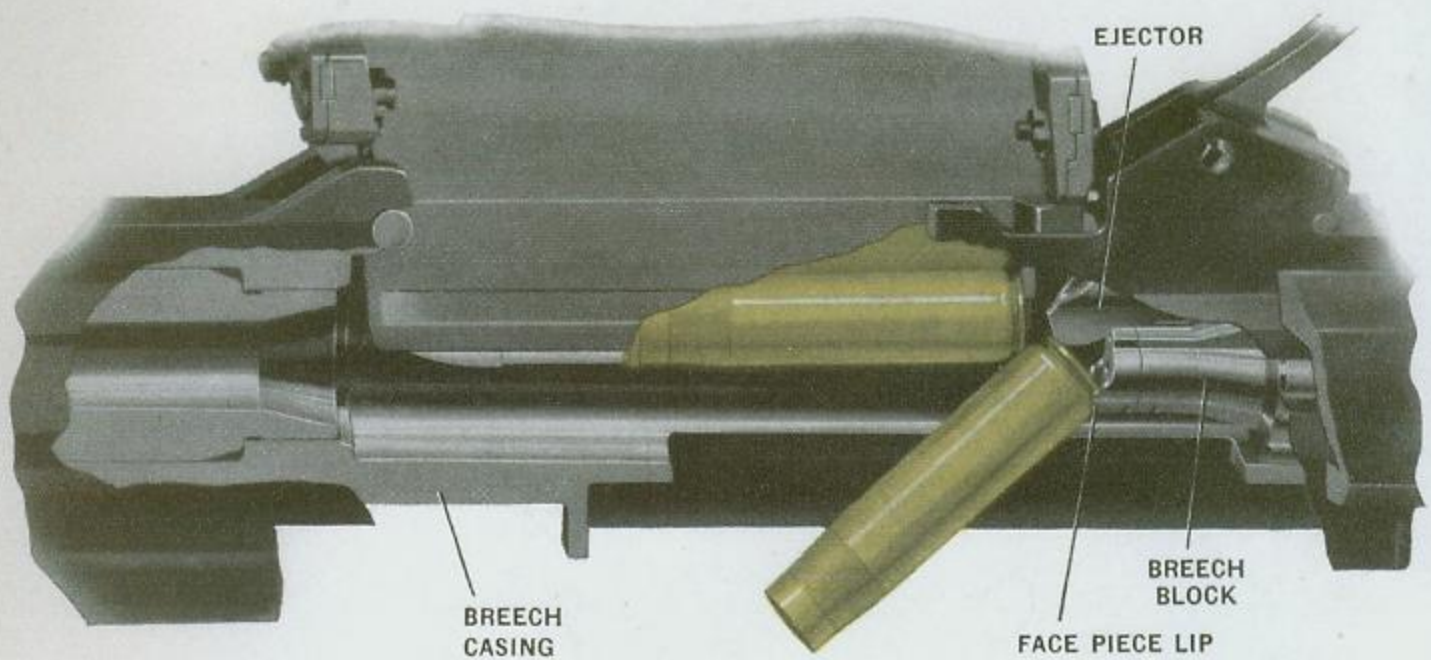

Figure 19—Ejecting Fired Cases

NOTE—It is of vital importance to the functioning of the gun, that the recoiling mass move rearward with enough speed to clear the gun of the fired case. A sufficiently hard blow from the toe of the ejector must be delivered on recoil, to force the fired case clear of the casing before the breech block has commenced to counterrecoil. **THE BOLT SHOULD NORMALLY RECOIL TO A POSITION WHERE THE FACE IS APPROXIMATELY 2.1 INCHES TO THE REAR OF THE FACE OF THE TOE OF THE EJECTOR.** The fired cartridge case has to get clear of the gun casing during the period the breech block is to the rear of the ejector.

Any factor tending to reduce the recoil, such as friction, tight extraction, etc., will also cause sluggish ejection, and this must be avoided, because of the possibility of a fired cartridge case failing to clear the counterrecoil of the breech block and causing a jam. The most common stoppage met with in this type of gun is caused by the sluggish ejection described above, with the fired case jammed between the breech block and the chamber face.

To reduce sluggish ejection the cartridges are supplied lightly greased, in their boxes. Care should be taken to see that this grease is maintained and replaced, if necessary. **A COAT OF MINERAL GREASE SHOULD BE ON EACH CARTRIDGE SO AS TO BE PERCEPTIBLE TO THE FINGERS. A LITTLE MINERAL GREASE APPLIED TO THE CARTRIDGE CASE, VISIBLE IN THE MOUTHPIECE OF A FILLED MAGAZINE SHORTLY BEFORE FIRING, IS ADVANTAGEOUS. OIL IS NOT TO BE USED AS A SUBSTITUTE FOR MINERAL GREASE.**

MAGAZINE INTERLOCK GEAR OPERATION

The front end of this gear is carried in the ejector and the rear portion operates in conjunction with the trigger gear. The purpose of the magazine interlock gear is to stop the gun in a cocked position after the last round of each magazine is loaded into the gun, irrespective of the position of the trigger. Otherwise the breech block mass would counterrecoil on an empty gun, making it necessary to recock by hand before firing could be continued with a freshly loaded magazine. **THE ACTION OF THE MAGAZINE INTERLOCK GEAR IS DESCRIBED AND ILLUSTRATED ON PAGES 48 TO 53.**

HAMMER PLATE OPERATION

This component is being described here, rather than in the Striker Gear section, because it is secured to the casing. See Figure 45. The Striker Gear group is carried by the breech block and is, therefore, a part of the recoiling group. This hammer plate is secured to the casing by dovetails and is locked by the hammer plate securing spring. It has two cam surfaces that actuate the hammer and thereby the striker pin. THE ACTION OF THE STRIKER GEAR IS DESCRIBED AND ILLUSTRATED ON PAGE 58.

DOUBLE LOADING STOP OPERATION

The purpose of the double loading stop gear is to make it impossible for the breech block to counter-recoil and load a round into the firing chamber unless the chamber is already empty. This avoids the jam that would occur if the rear end of a cartridge case had been torn away, leaving a portion of the case jammed in the firing chamber.

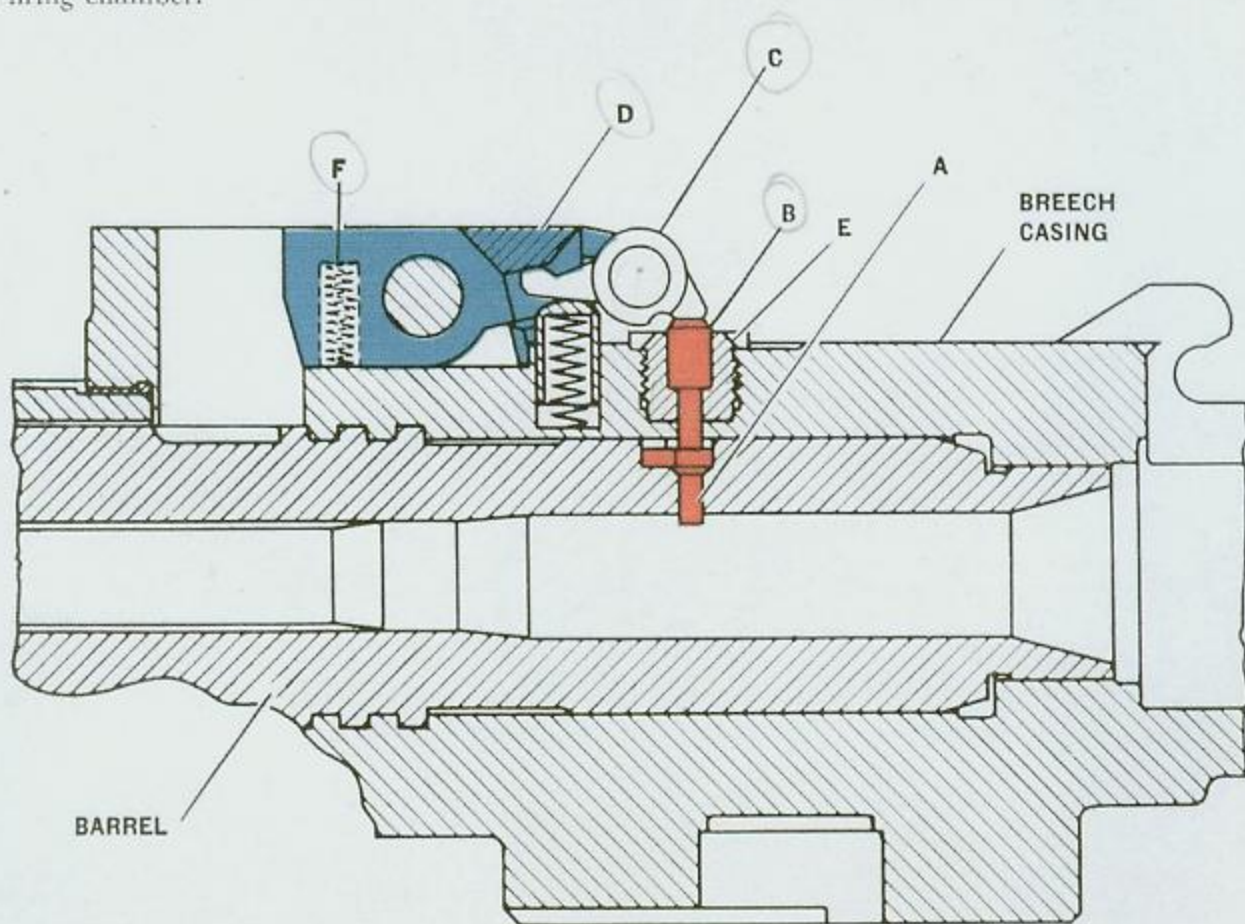

Figure 20—Double loading stop gear. Gun is in cocked position with stop plunger protruding into the firing chamber

- | | |
|---|---|
| A—Double loading stop plunger—lower (OE-1011) | D—Double loading stop (OE-1054) |
| B—Double loading stop plunger—upper (OE-1080) | E—Double loading stop guide bushing (OE-1055) |
| C—Double loading stop lever (OE-1053) | F—Double loading stop spring (OE-1336) |

The double loading stop (D) with its operating lever (C), upper plunger (B) and lower plunger (A) are shown in Figure 20 in the position they occupy when the gun is cocked. The double loading stop plunger (A) is projecting into the chamber and is the end actuated by the cartridge case. This lower plunger (A) lifts the upper plunger (B) against the rear toe of the double loading stop operating lever (C) lowering its front end; this action permits the double loading stop to rotate about its axis under the pressure of its springs (F). The double loading stop (D) acts as a catch to hold the bolt mass to the rear.

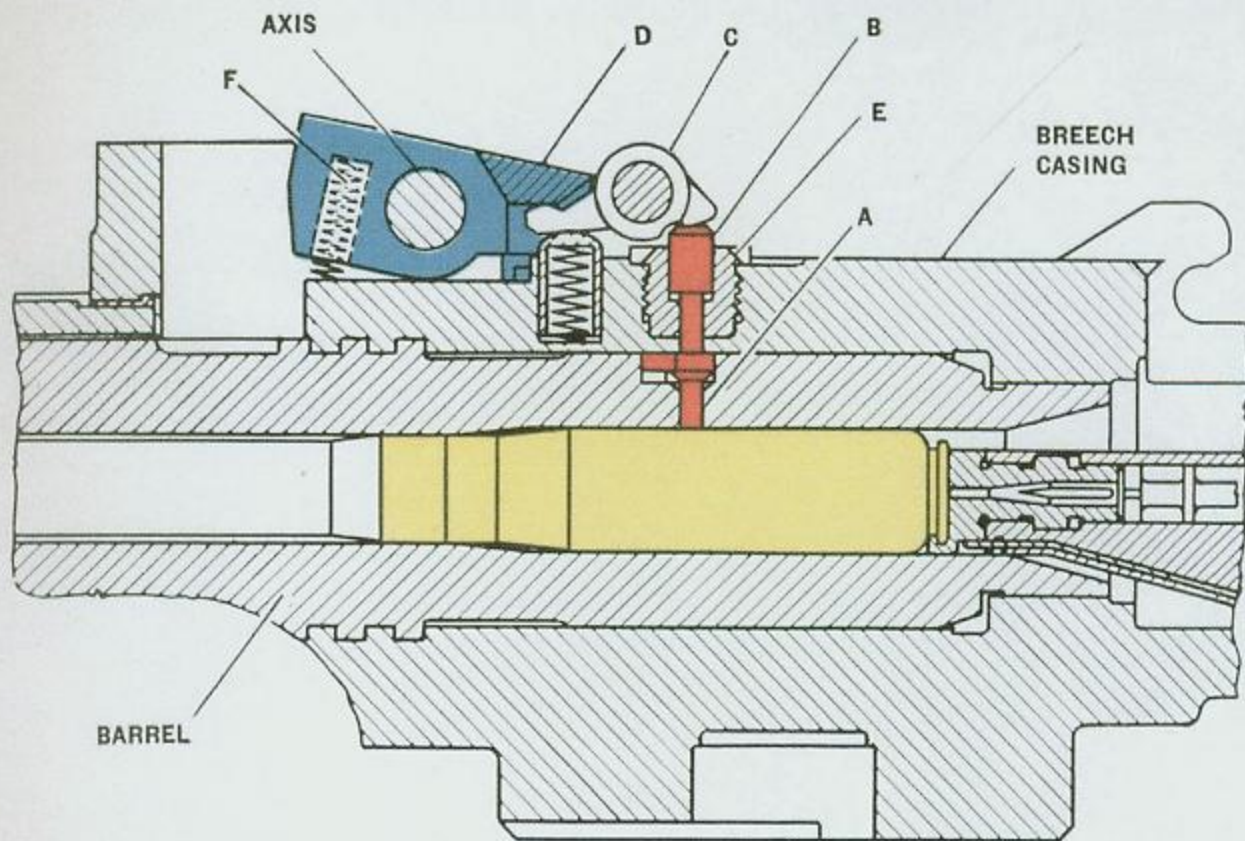

Figure 21—Double Loading Stop Gear. Gun has fired and cartridge is in firing chamber

- | | |
|---|---|
| A—Double loading stop plunger—lower (OE-1011) | D—Double loading stop (OE-1054) |
| B—Double loading stop plunger—upper (OE-1080) | E—Double loading stop guide bushing (OE-1055) |
| C—Double loading stop lever (OE-1053) | F—Double loading stop spring (OE-1336) |

The position of these parts when a cartridge is in the firing chamber is shown in Figure 21. The front end of the double loading stop (D) is raised by spring (F) and the rear end has fallen until it is in the path of the stop plates mounted one on each breech bar.

NOTE—The positions of the lower plunger (A), upper plunger (B) and lever (C) remain the same in Figures 21, 22 and 23. The cartridge case is assumed to have ripped apart in Figures 21 and 22 with the part remaining, still holding lower plunger (A) flush against the firing chamber wall. The double loading stop (D) remains free to rotate, to a limited extent.

The left breech bar is shown, see Figure 22, recoiling to the rear carrying with it the stop plate marked "L". (On the right breech bar the stop plate is marked "R".) The rear end of the stop plates is sloped to lift the double loading stop (D), Figure 22, against the pressure of its springs. The springs assert themselves after the hardened stop plates have passed the double loading stop. See Figure 21. Faces on the rear end of the double loading stop (D) then intercept the hardened stop plates on the breech bars as the breech bars counterrecoil and thereby hold the entire recoiling mass to the rear as shown in Figure 23.

When the gun is operating normally the fired cartridge case is ejected before the breech bars have recoiled far enough to reach the double loading stop (D), Figures 22 and 20. When ejection of the fired cartridge case occurs, the double loading stop lower plunger (A) is no longer held outward by the cartridge case and the whole system is then returned to its inward position by the spring under the double loading stop lever (C).

GUN MECHANISM

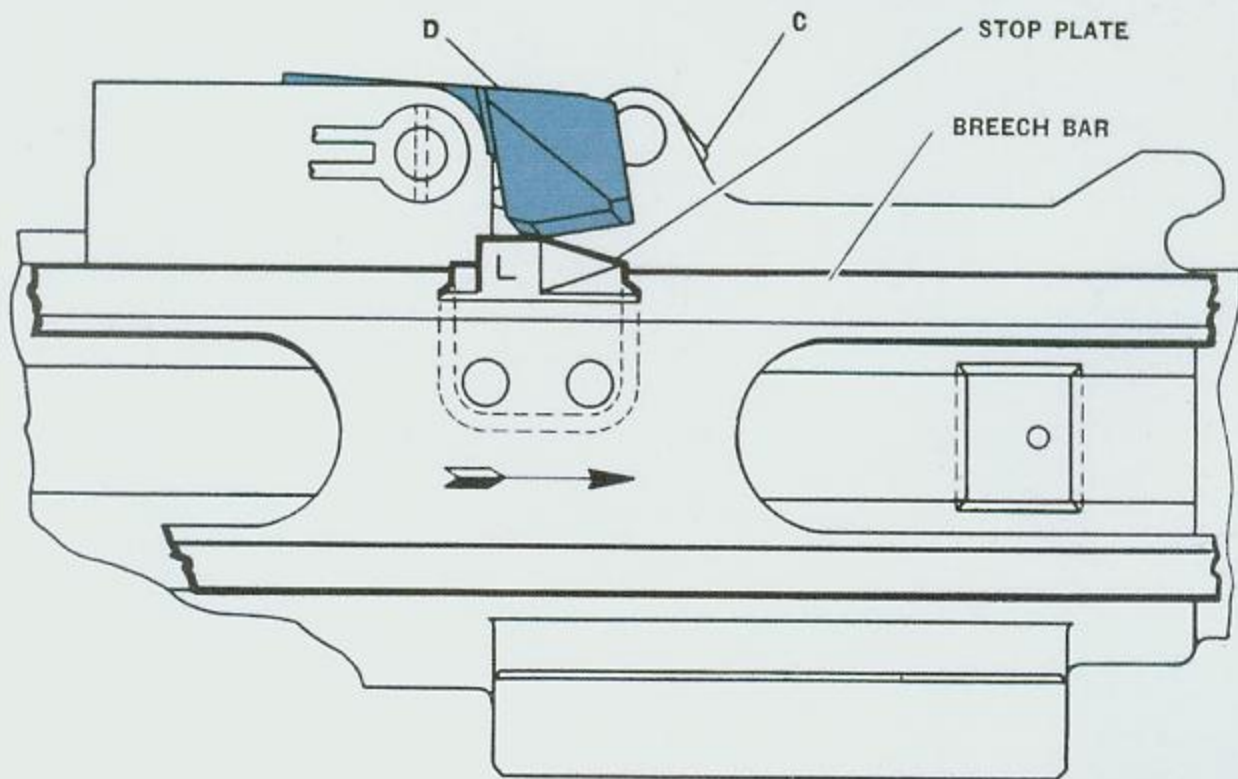

Figure 22—Double Loading Stop Gear. Part of cartridge shell left in chamber as recoil takes place

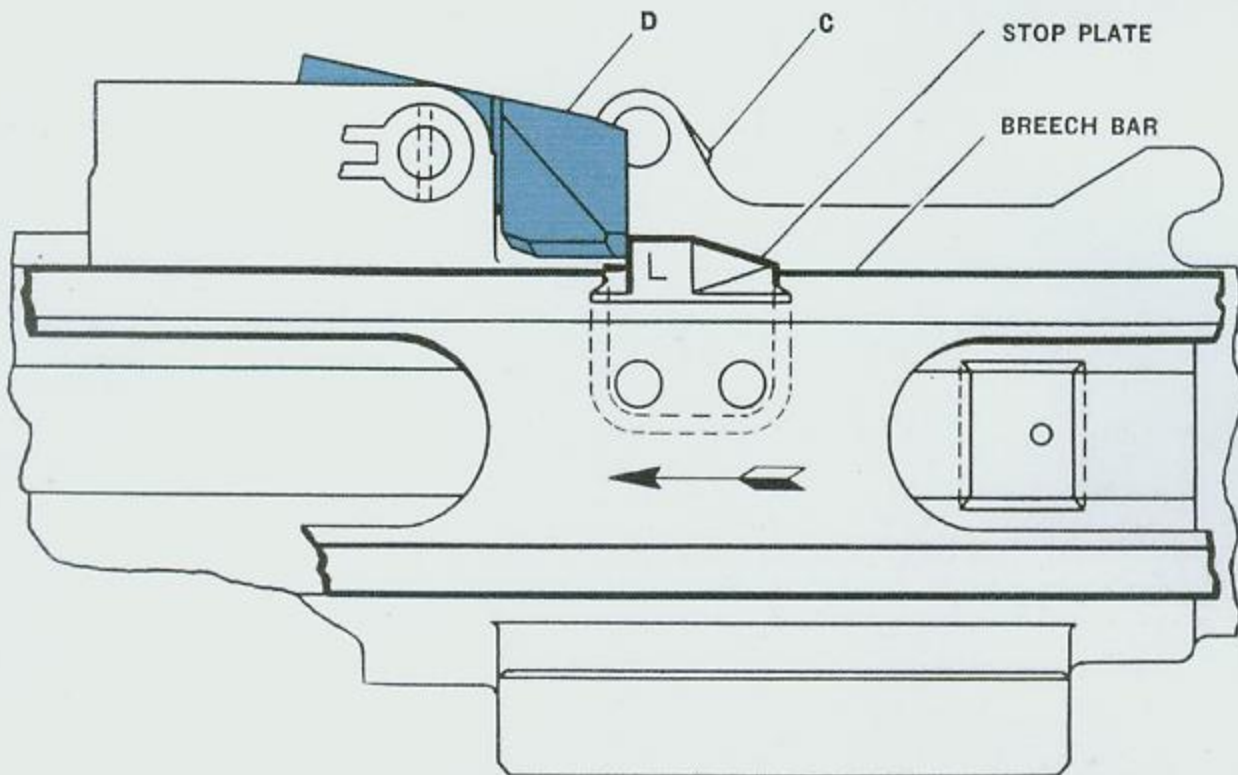

Figure 23—Double Loading Stop Gear. Counterrecoil is arrested by the stop plate bearing against the double loading stop

C—Double loading stop lever (OE-1053) D—Double loading stop (OE-1054)

GUN MECHANISM

Interception of the breech bars by the stop plates on breech bars intercepting the double loading stop (D) occurs only if a portion of the fired cartridge case remains in the chamber in line with plunger (A).

The double loading stop lower plunger (A) is shaped to lie flush with the curve of the firing chamber wall. This lower plunger (A) has a shoulder on its outer end that prevents it from turning and also limits the travel of the lower plunger. The upper plunger (B) is limited on its inward travel by a shoulder on the guide bushing (E) and on its outward travel by the rear end of operating lever (C), Figures 20 and 21.

A new style double loading stop plunger—lower is used in the Mark 4 Mod. 1 gun barrel (OE-1013). This plunger (OE-1014), differs from the former part, (OE-1011), in that it has a round head and its lower end is flat instead of curved to the inside radius of the gun barrel chamber.

NOTE—THE DOUBLE LOADING STOP OPERATES IN THE EVENT OF A TORN CARTRIDGE CASE BEING LEFT IN THE CHAMBER AND IN CONTACT WITH THE LOWER PLUNGER, Figure 79. IF THE PORTION OF THE TORN CARTRIDGE CASE LEFT IN THE CHAMBER IS FORWARD OF THE STOP, THE DOUBLE LOADING STOP WILL NOT OPERATE AND A JAM WILL OCCUR.

TRIGGER MECHANISM

Chapter 4

The illustrations used in this chapter show the action of the parts diagrammatically in order to best explain their operation. The gun assembly drawing, Plate 1, shows all parts in their correct proportions.

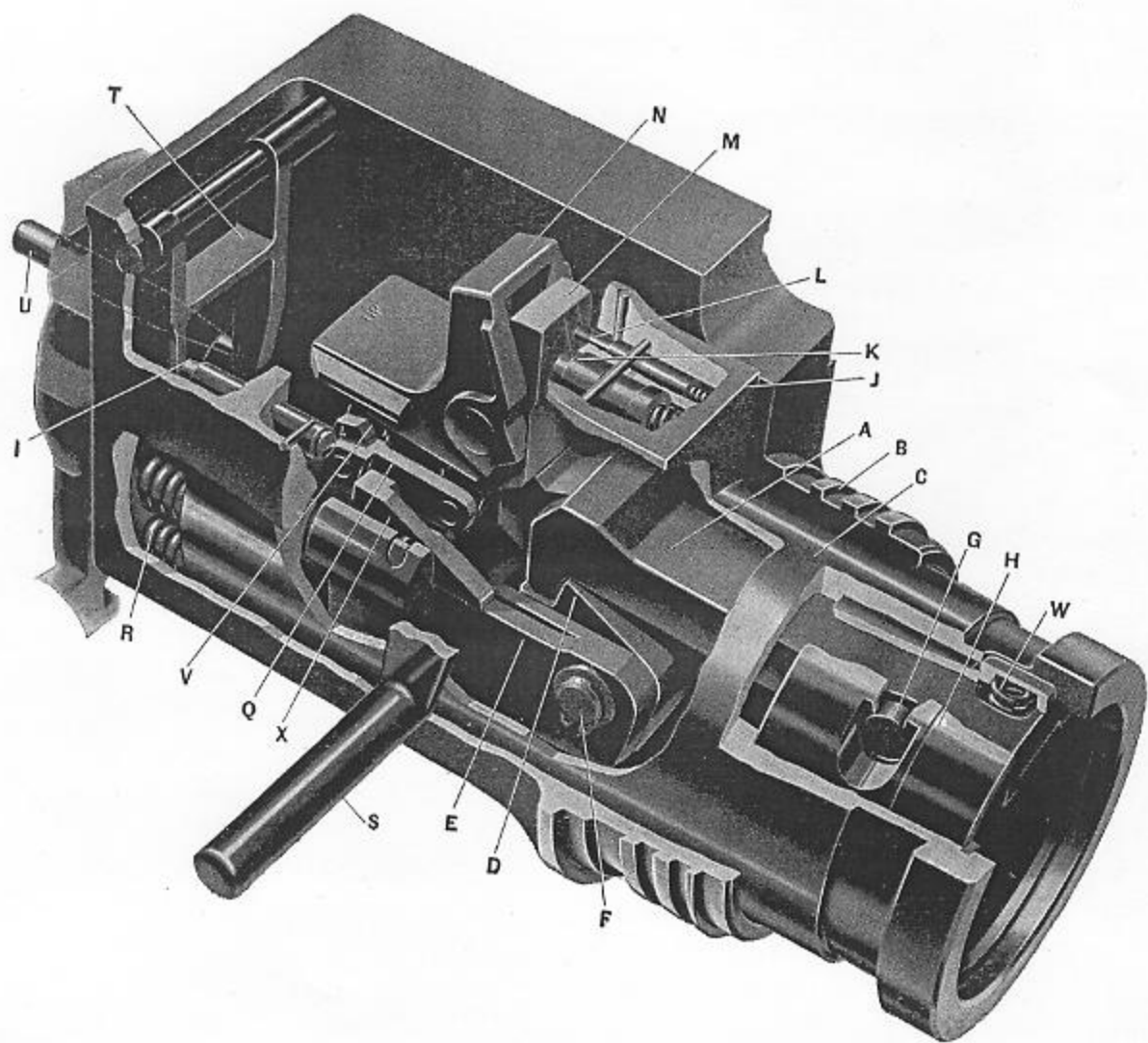

Figure 24—Trigger Mechanism In Cocked Position

A—Trigger hook (OE-1216)
B—Breech casing (OE-1040)
C—Trigger casing (OE-1202)
D—Recoil sear (OE-1317)
E—Breech bolt (OE-1315)
F—Recoil sear axis bolt (OE-1319)
G—Trigger hook axis bolt (OE-1217)
H—Trigger hook holder (OE-1215)
I—Trigger pawl tripping bolt (OE-1225)
J—Parallelogram spring box (OE-1211)
K—Parallelogram lever plunger—rear (OE-1212)

L—Parallelogram lever plunger—top (OE-1213)
M—Parallelogram lever—rear (OE-1203)
N—Parallelogram lever—top (OE-1204)
O—Parallelogram lever—bottom (OE-1206)
R—Trigger buffer springs (OE-1326)
S—Trigger (OE-1220)
T—Magazine interlock fork (OE-1230)
U—Magazine interlock rod (OE-1075)
V—Parallelogram lever—front (OE-1205)
W—Trigger hook spring (OE-1343)
X—Breech pawl (OE-1104)

TRIGGER MECHANISM

TRIGGER FUNCTION

The principal feature of the trigger group is that a trigger hook (A), Figure 24, mounted on the breech casing (B), (a non-recoiling part) can hook onto the recoiling sear (D) that is on the end of the breech bolt (E) and thereby hold the recoiling mass in the cocked position, Figure 24.

Additional features are:

(A). The trigger hook (A) can be kept in the released position by keeping the trigger pressed in order to allow automatic fire:

(B). The trigger hook automatically intercepts the recoil sear and holds the recoiling mass in the cocked position when the trigger is released or when the last round in the magazine has been fired, Figure 25. It is, therefore, unnecessary to recock by hand to resume firing or after changing magazines.

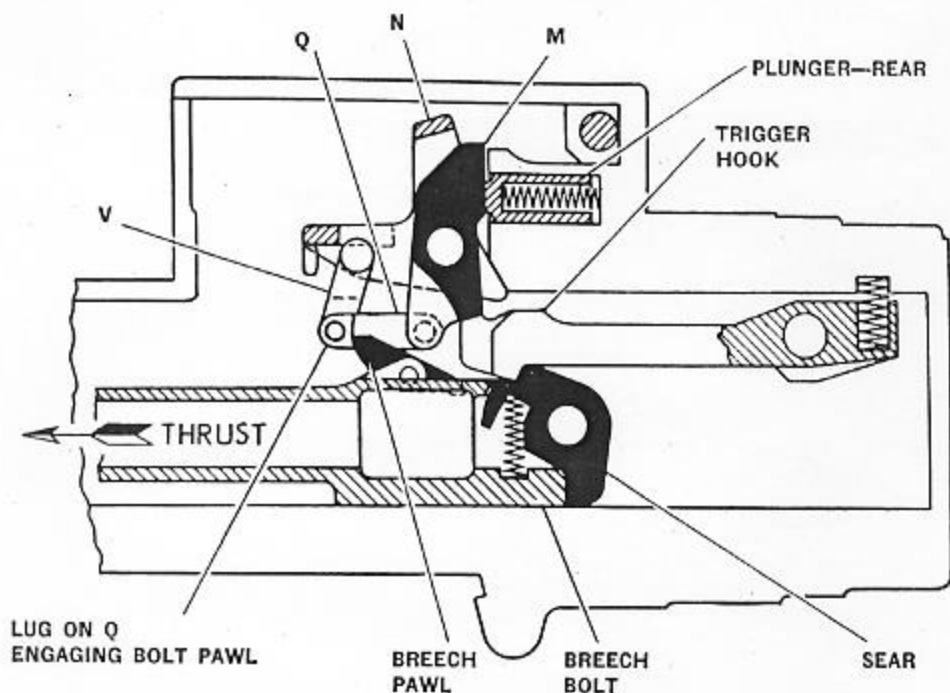

Figure 25—Recoiling mass being held in a cocked position

M—Parallelogram rear lever
N—Parallelogram top lever

Q—Parallelogram bottom levers
V—Parallelogram front lever

The recoiling mass is shown in Figures 24 and 25 held in the cocked position. The barrel springs are compressed and are tending to pull the breech block toward the muzzle (looking at Figures 24 and 25 this would be to the left). The recoil sear (D), Figure 24, is attached to the rear end of the breech bolt by an axis bolt (F).

The trigger hook (A) is hooked on the recoil sear (D), thereby preventing the breech block and its bolt (E) from moving forward. This trigger hook (A) is pivoted on an axis bolt (G) in the trigger hook holder (H). The trigger hook holder (H) rests in the trigger casing (C).

The trigger hook is **always** endeavoring to disengage from the recoil sear. This attempt to disengage is due to the action of two forces:

1. The spring (W) at the end of the trigger hook (A), Figure 24, is exerting pressure on the end of the trigger hook (A) to lift the opposite end from the recoil sear (D).

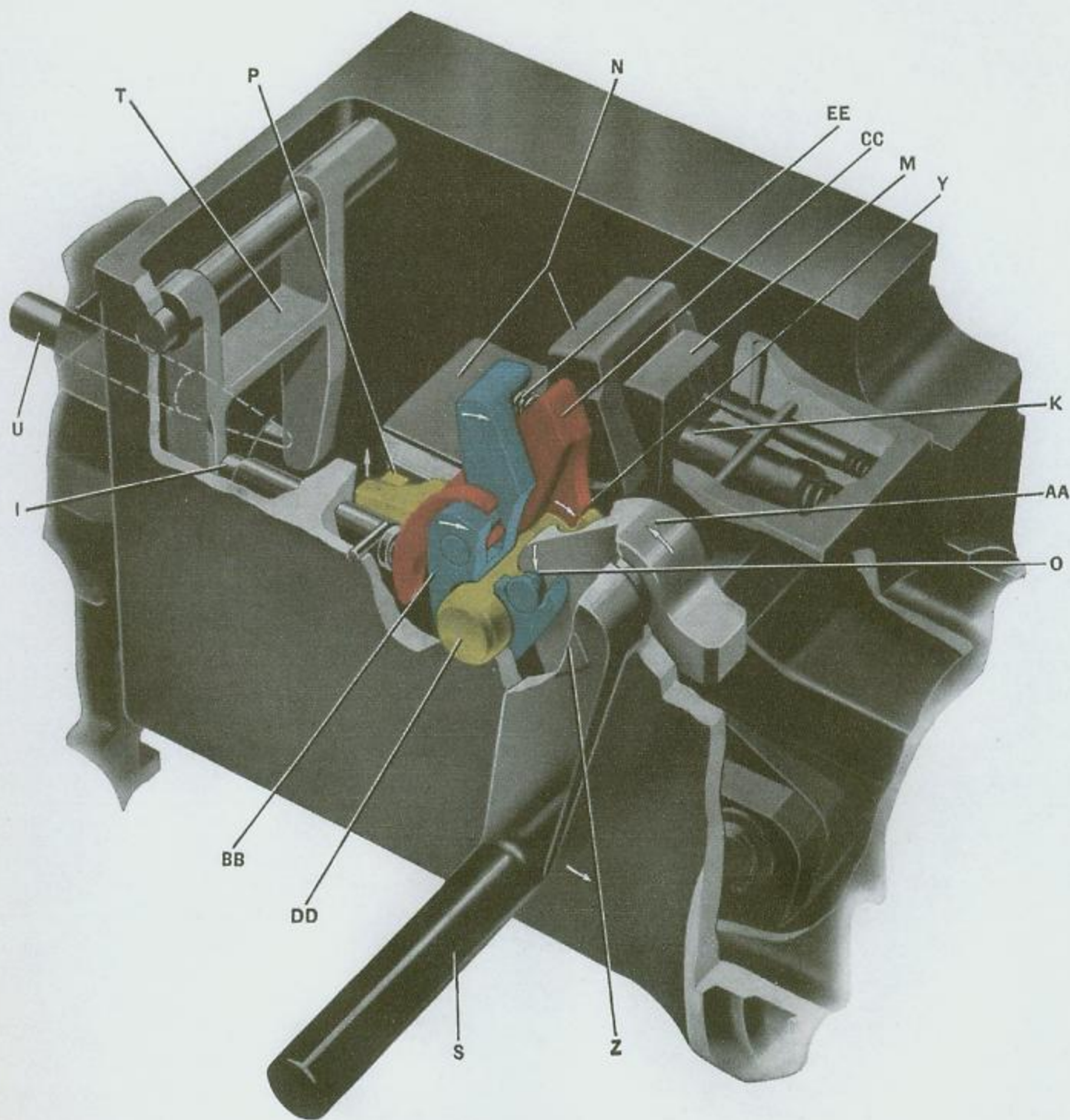

Figure 26—Trigger action on parallelogram

I—Trigger pawl tripping bolt (OE-1225)
 M—Parallelogram lever—rear (OE-1203)
 N—Parallelogram lever—top (OE-1204)
 O—Point of contact between trigger intermediate lever and trigger pawl holder
 P—Point of contact between trigger crank toe and parallelogram top lever
 S—Trigger (OE-1220)
 T—Magazine interlock fork (OE-1230)

U—Magazine interlock rod (OE-1075)
 Y—Point of contact between trigger pawl and trigger crank
 Z—Trigger retaining bolt (OE-1221)
 AA—Trigger intermediate lever (OE-1218)
 BB—Trigger pawl holder (OE-1219) shown in BLUE
 CC—Trigger pawl (OE-1222) shown in RED
 DD—Trigger crank (OE-1223) shown in YELLOW
 EE—Trigger pawl spring (OE-1332)

TRIGGER MECHANISM

2. There is an upward thrust on the trigger hook that is caused by the forward pull of the barrel spring acting on the inclined faces of the sear and trigger hook. This is illustrated in Figure 25.

NOTE—These faces, it will be noted, do not constitute an interlocking hook, but are at such an angle that the barrel spring pull on recoil sear tends to force the trigger hook upward and out of the engagement; simultaneously the trigger hook spring is exerting its pressure on the trigger hook trying to disengage it from the recoil sear.

COCKED POSITION

In the cocked position, Figure 25, upward movement of the trigger hook is blocked by the lever (M). This lever forms the rear member of a parallelogram consisting of the following:

1. Parallelogram top lever (N), Figures 24 and 25.
2. Parallelogram front lever (V).
3. Parallelogram bottom levers (Q) (left and right).
4. Parallelogram rear lever (M).

The four corners of the parallelogram are formed by axis pins thus allowing the four levers to pivot on each other. The pin connecting the top and rear levers (N and M) is also mounted in the trigger casing, Figure 24.

As previously stated there is an upward thrust on the trigger hook that is caused by the forward pull of the barrel spring acting on the inclined faces of the sear and trigger as shown in Figure 25. This upward thrust combined with the pressure of the spring loaded parallelogram lever plunger, rear (K), Figure 24, tends to rotate parallelogram rear lever (M) counterclockwise and thus pull the bottom levers (Q) to the right. These bottom levers (Q), however, cannot go to the right because they are held to the left by the breech bolt pawls (X) bearing against the lugs, Figures 24 and 25, on the bottom levers (Q). There are two levers (Q) and they form the bottom levers of the parallelogram against which the right and left breech pawls (X), Figure 24, bear. These two breech pawls (X) are pivoted on the breech bolt (E), Figure 24. The full weight of compressed barrel springs on the breech bolt makes it impossible for the two levers (Q) to be pulled to the right and, therefore, prevents the trigger hook from disengaging.

FIRING ACTION

Pressing the trigger will so move the parallelogram levers, Figure 29, that the trigger hook will be released from the recoil sear and the trigger hook will be kept clear of the path of the recoiling sear as long as the trigger is pressed or until the magazine is empty. The firing is entirely automatic.

When firing, the pressing of the trigger (S) Figure 26, turns the trigger retaining bolt (Z) in a counterclockwise direction. The trigger intermediate lever (AA) is on the trigger retaining bolt (Z) and is also turned. A recess in this trigger intermediate lever (AA), Figure 26, engages a pin on the trigger pawl holder (Blue) and, as illustrated, this trigger pawl holder is made to turn on its axis in a clockwise rotation.

The trigger pawl holder (Blue), Figure 26, has an axis pin (also blue), and on it is placed the trigger pawl (Red). In between the pawl holder (Blue) and the pawl (Red) is a spring (EE) that is under compression in order to keep a toe on the pawl (Red) in engagement at point (Y) with a notch on the trigger crank (Yellow). As stated above, pressing the trigger turns the trigger bolt (Z), Figure 26, counter-clockwise; the trigger intermediate lever (AA), Figure 26, being on the same bolt is also turned counterclockwise; the recess (O) in the trigger intermediate lever (AA) turns the pawl holder (Blue) clockwise and carries the trigger pawl (Red) with it as a unit. As stated above, the toe of the trigger pawl is in engagement with the notch on the trigger crank and, therefore, when the trigger pawl is rotated clockwise the trigger crank also is rotated clockwise.

At the front end of the trigger crank (Yellow) is another toe that lies under a lip at point (P) of the parallelogram top lever (N). Movement of the trigger crank (Yellow) pushes up the front end of parallelogram top lever (N) causing it to rotate about its axis pin and forcing the parallelogram to slew into the position shown in Figure 28. Parallelogram bottom left and right levers (Q), Figure 28, are rotated about their axis on the parallelogram rear lever (M). The front end lugs (Q) of parallelogram bottom levers that

TRIGGER MECHANISM

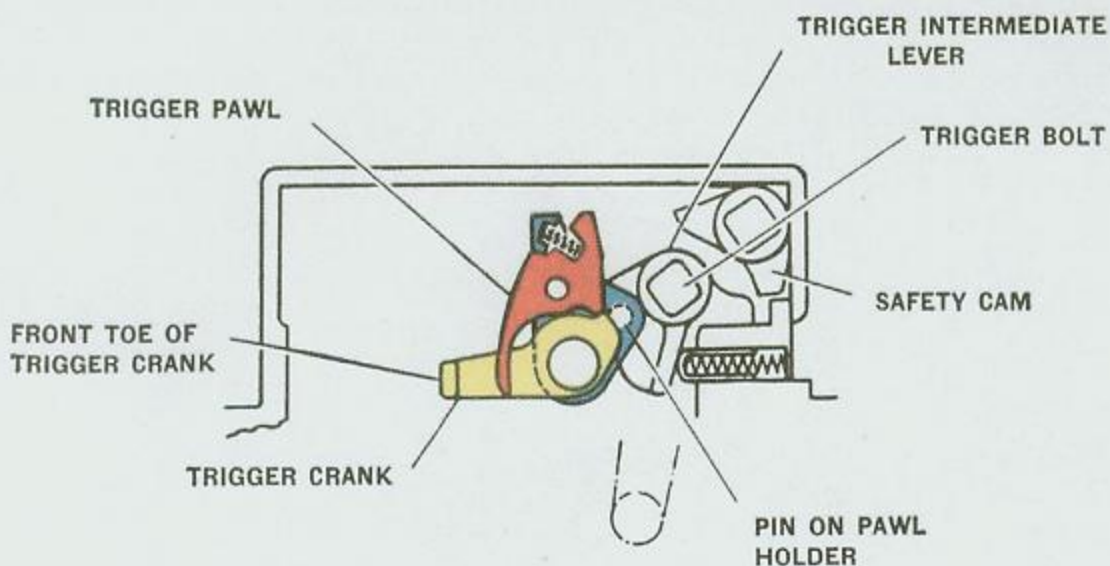

Figure 27—Trigger to trigger crank operation

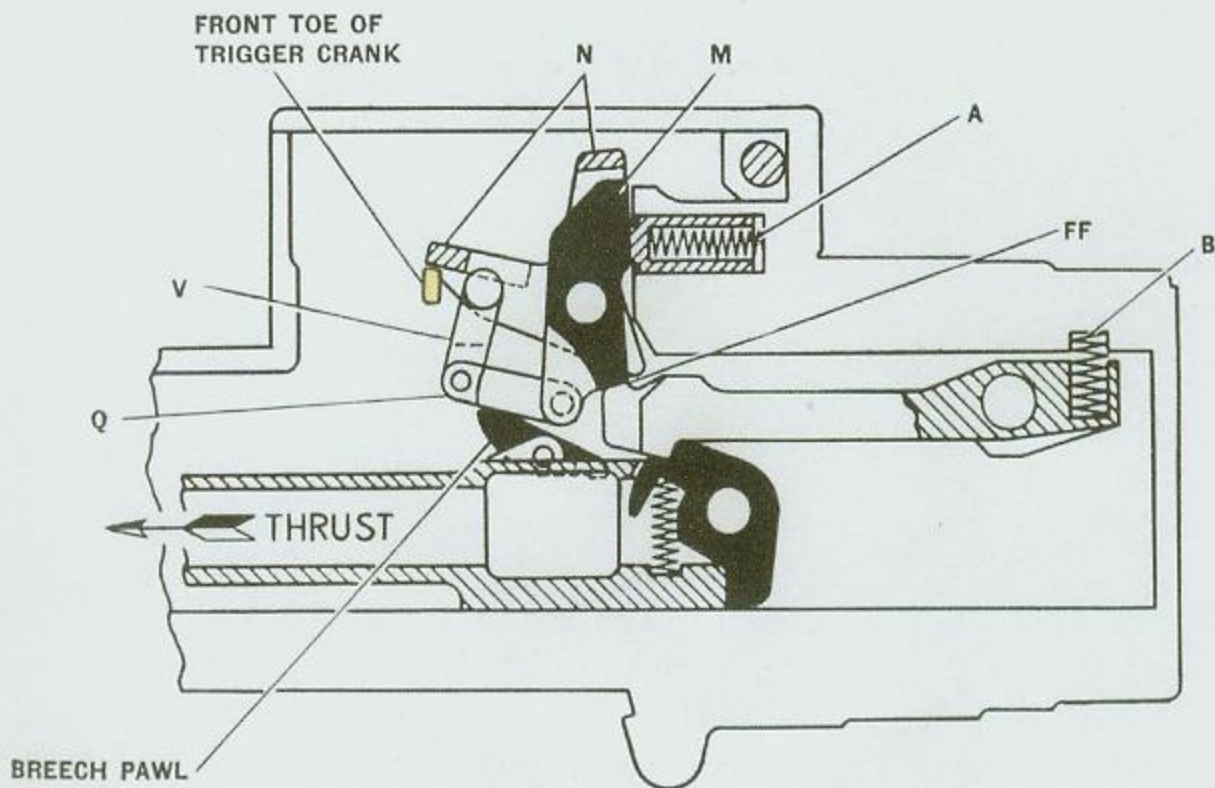

Figure 28—Recoiling mass about to be released to fire the gun, the parallelogram being moved by trigger crank

A—Parallelogram rear lever plunger spring
 B—Trigger hook spring
 M—Parallelogram rear lever
 N—Parallelogram top lever

Q—Parallelogram bottom levers
 V—Parallelogram front lever
 FF is the point of contact between the parallelogram rear lever and trigger hook

TRIGGER MECHANISM

were bearing against the breech pawls, Figure 28, are now disengaged. The attempt of the trigger hook to disengage itself from the recoil sear, is now about to be realized because the levers (Q) cannot restrain it, inasmuch as they are freed of the breech pawls and barrel spring. Levers (Q) can now go to the right, thus forcing lever (M) counterclockwise. Springs also assist in this action as follows:

Parallelogram Rear Lever Plunger Spring (A), Figure 28

Trigger Hook Spring (B)

The movement of the parallelogram rear lever (M) brings it into line with a recess in the trigger hook, allowing the trigger hook to rotate upward, about its axis and into the position shown in Figure 29 where it is clear of the recoil sear. This disengagement from the recoil sear releases the entire breech block mass so that it counterrecoils, under the push of the barrel spring, and fires the gun.

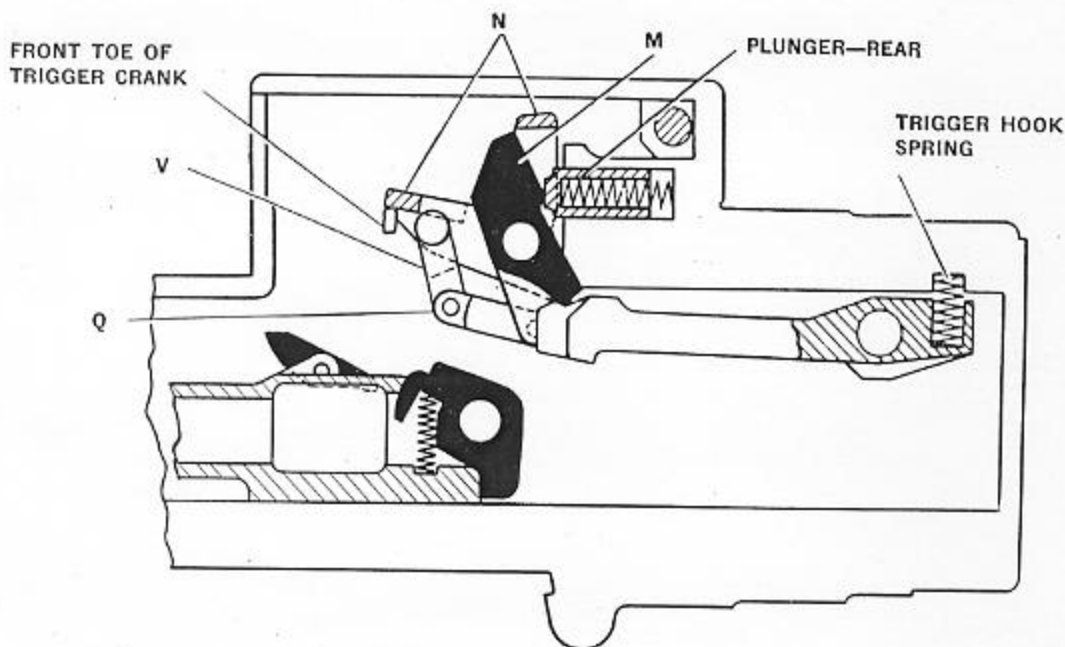

Figure 29—Recoiling mass released to fire the gun

M—Parallelogram rear lever
N—Parallelogram top lever

Q—Parallelogram bottom levers
V—Parallelogram front lever

The trigger pawl (Red), Figures 26 and 27, is on an axis pin in a trigger pawl holder (Blue). In between the pawl holder and the pawl is a spring (EE), Figure 26, that is under compression in order to keep a toe on the pawl (Red) in engagement at point (Y) with a notch on the trigger crank (Yellow). During the firing travel of the trigger pawl it remains in engagement with the trigger crank (Yellow).

This action retains the trigger gear in the position shown in Figure 29 as long as the trigger is kept pressed to the rear and there are cartridges in the magazine. In the position illustrated in Figure 29, the lugs on the parallelogram bottom levers (Q) are clear of the recoil and counterrecoil path of the breech pawls. The trigger hook is kept clear of the recoil sear by the trigger hook spring.

Releasing the trigger allows the trigger intermediate lever (AA), Figure 26, trigger pawl holder (Blue), trigger pawl (Red), and trigger crank (Yellow) to return to the position shown in Figure 26. The parallelogram top lever (N) is lowered by its plunger spring, Figure 30. This drops parallelogram front lever (V),

TRIGGER MECHANISM

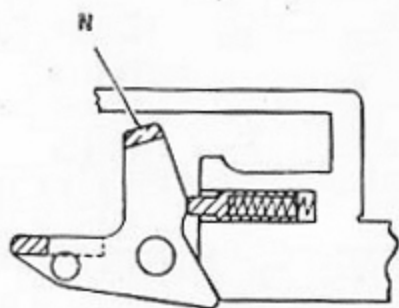

Figure 30—Action of spring plungers against parallelogram top lever

Figure 31, and parallelogram bottom right and left levers (Q) into such a position that the lugs on bottom levers (Q) lie in the recoil and counterrecoil path of the breech pawls.

On the breech block mass recoil the breech pawls ride under the bottom levers (Q), Figure 31, and, during the subsequent counterrecoil, engage them again as shown in Figure 31. The parallelogram lever (M) is still in the recess in the trigger hook as shown in Figures 29 and 31, and it is being kept in the recess by its spring. When the lugs on bottom levers (Q) are engaged by the breech pawls the effect is to pull the bot-

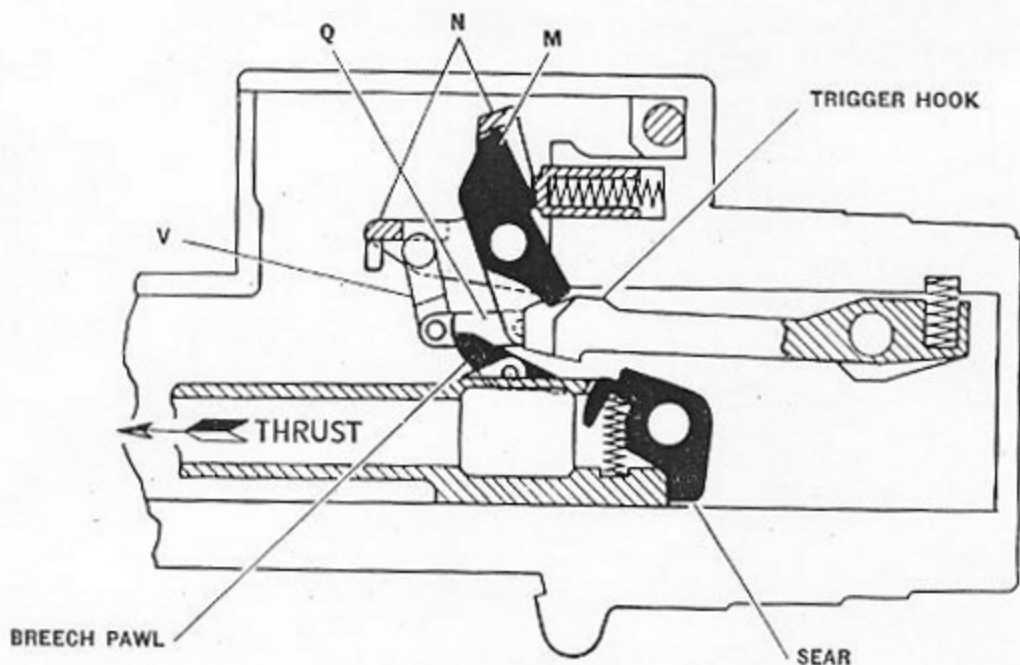

Figure 31—Trigger released, recoiling mass about to start counterrecoil and be held in cocked position by breech pawls engaging parallelogram bottom lever lugs

M—Parallelogram rear lever
N—Parallelogram top lever

Q—Parallelogram bottom levers
V—Parallelogram front lever

TRIGGER MECHANISM

tom levers (Q) forward. This movement rotates the parallelogram rear lever (M) clockwise causing a face on it to press on the toe (FF), Figure 26, of the trigger hook forcing it down into engagement with the recoiling sear. The breech block mass is thus intercepted and held in the cocked position. See Figure 28, "Recoiling mass in cocked position."

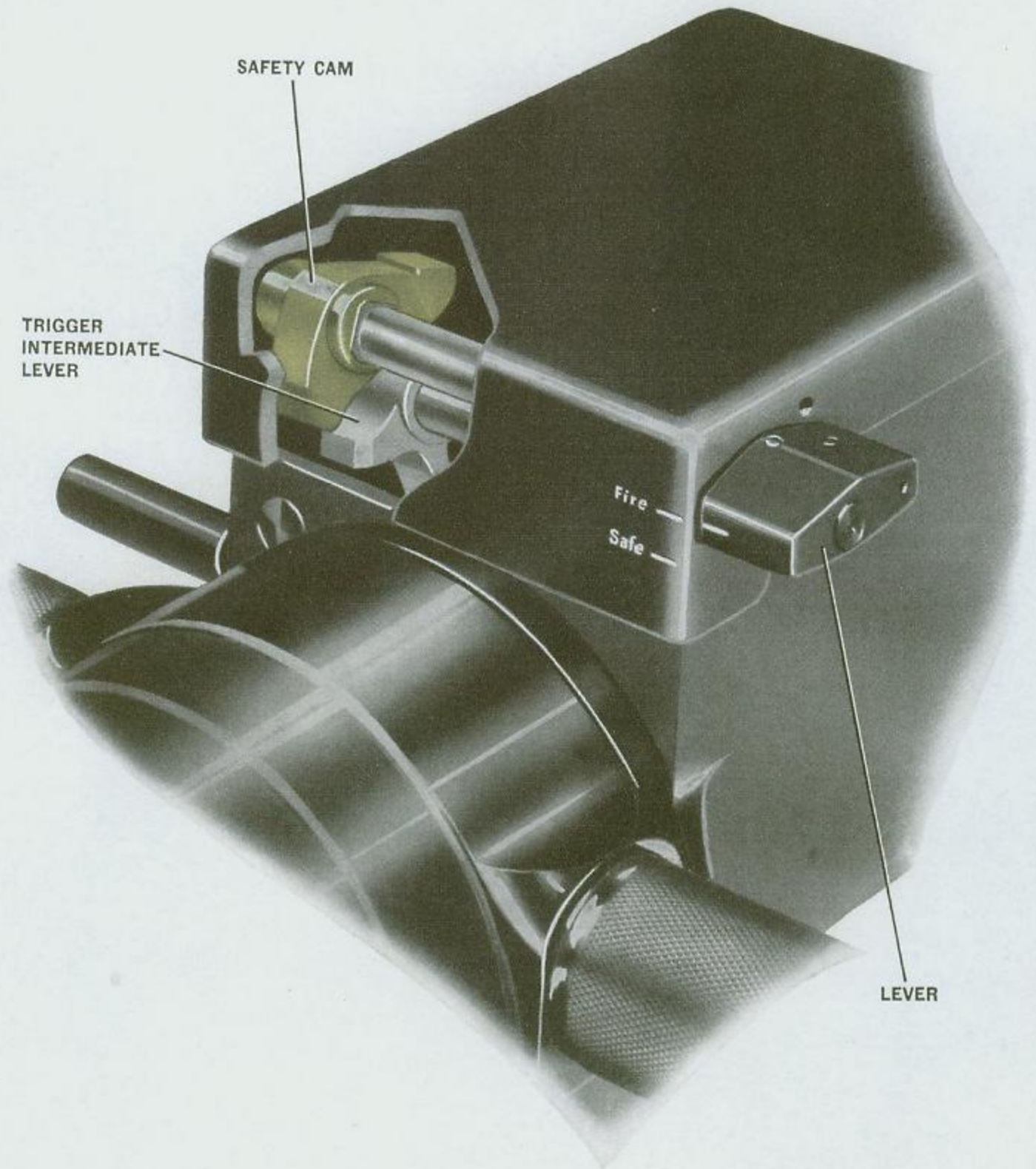

Figure 32—Safe/Fire Gear

TRIGGER MECHANISM

SAFE/FIRE GEAR

A safe/fire lever is fitted close to the right hand-grip. When put to the "Safe" position it turns an axis bolt and rotates the safety cam.

The toe of the safety cam contacts the rear toe of the trigger intermediate lever thus locking it and preventing any movement. When put to the "Fire" position, Figure 32, the safety cam is rotated clear of the trigger intermediate lever.

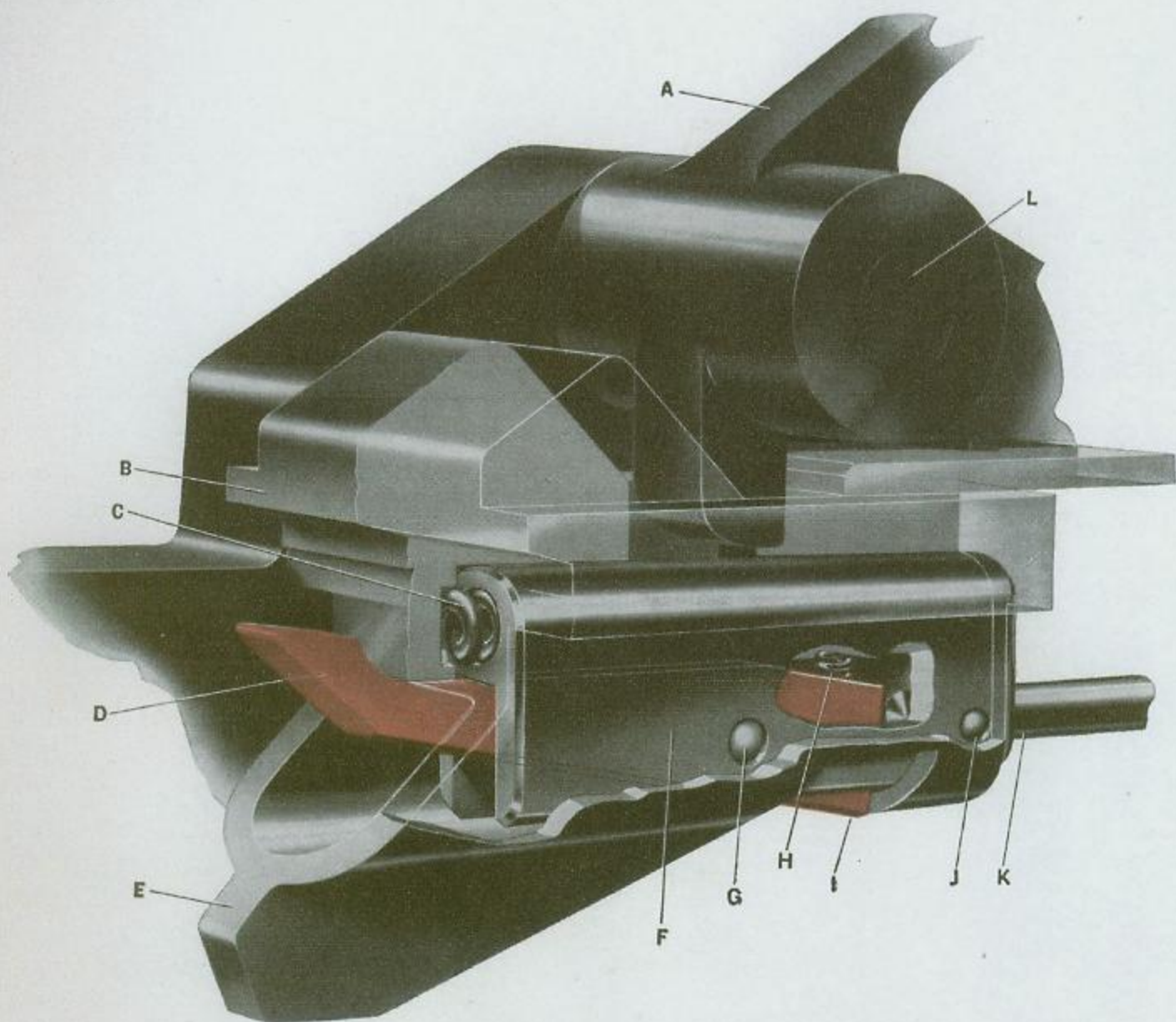

Figure 33—Magazine interlock gear in firing position

- A—Magazine catch lever (OE-1043)
- B—Magazine securing lug on ejector
- C—Interlock carrier spring (OE-1340)
- D—Interlock lever (OE-1074)
- E—Ejector (OE-1045)
- F—Interlock carrier (OE-1066)
- G—Axis bolt (OE-1067) holding interlock lever to interlock carrier

- H—Magazine interlock lever spring (OE-1330)
- I—Magazine interlock lever in catch recess in ejector
- J—Axis pin (OE-1261) holding interlock rod to interlock carrier
- K—Interlock rod (OE-1075)
- L—Magazine catch lever spring axis bolt (OE-1076)

MAGAZINE INTERLOCK GEAR

The purpose of the magazine interlock gear is to stop the gun in the cocked position after the last round of each magazine is loaded into the gun, regardless of the position of the trigger. Otherwise the breech block mass would counterrecoil on an empty gun, making it necessary to recock by hand before firing could be continued with a fresh magazine.

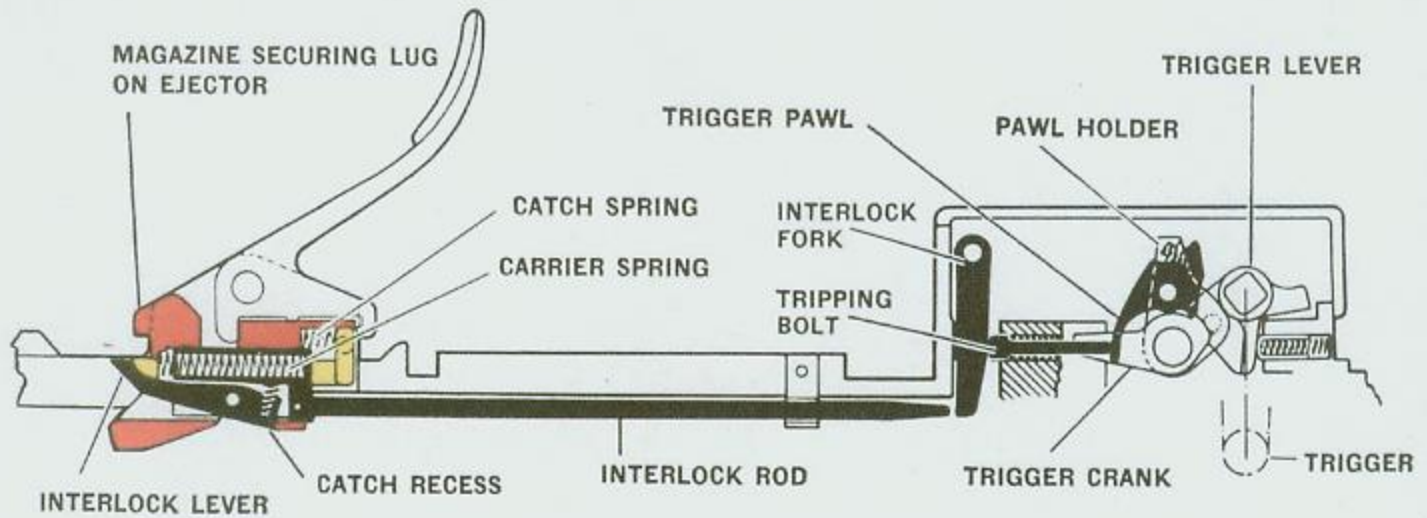

Figure 34—Magazine interlock gear in firing position

MAGAZINE INTERLOCK GEAR ACTION

The positions of the various parts of this gear, while the gun is firing, are shown in Figure 33. The

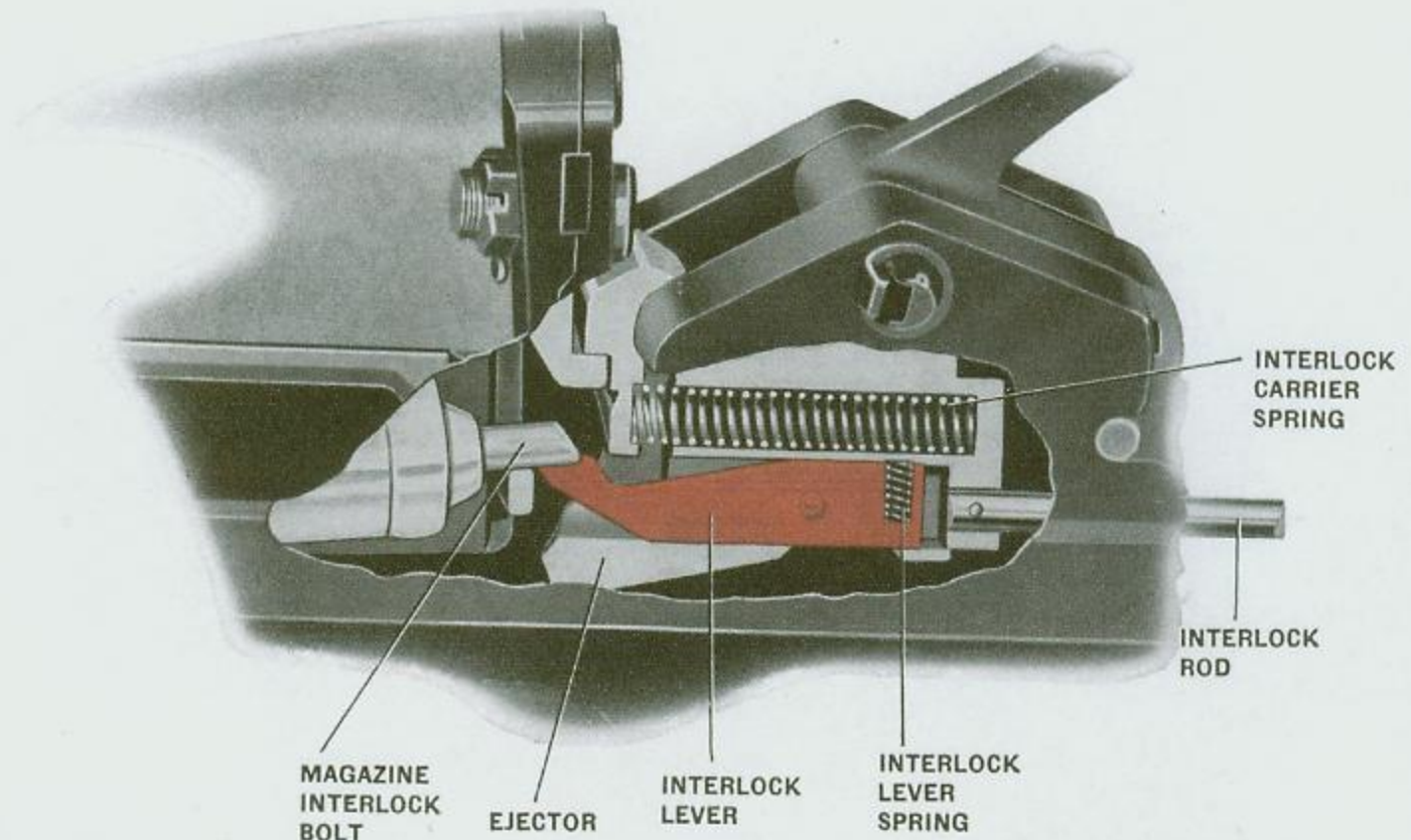

Figure 35—Magazine is empty—last round has been fired—interlock gear tripped by feeder bolt thus tripping trigger gear and keeping the gun cocked

TRIGGER MECHANISM

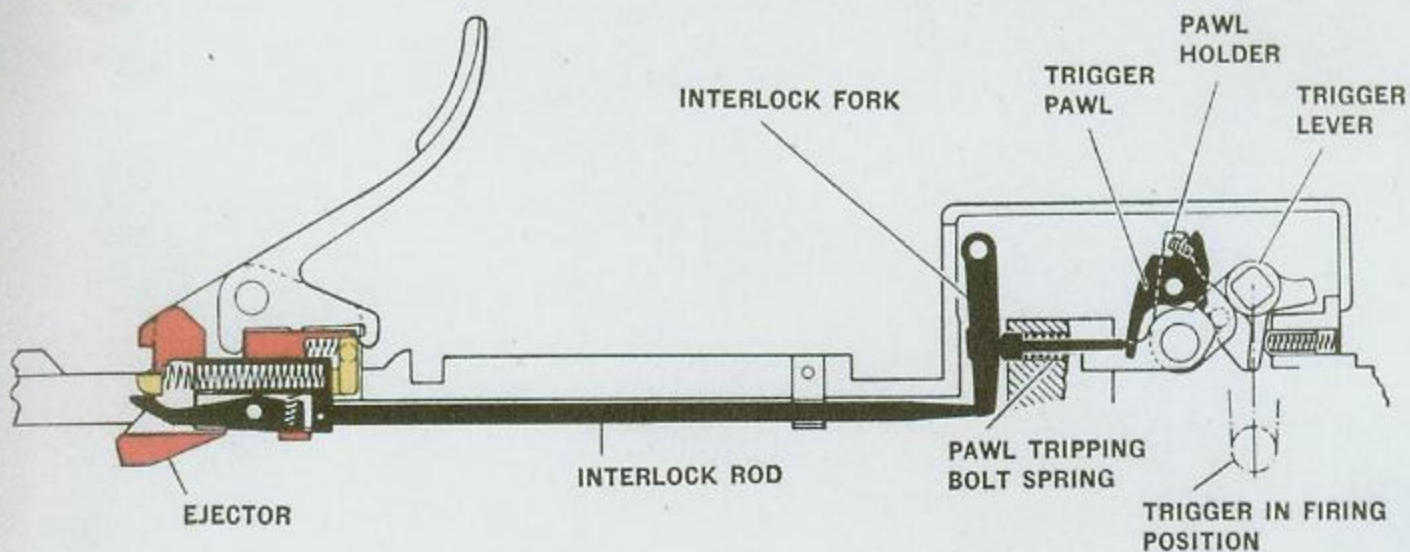

Figure 36—Magazine interlock gear. Last round has been fired. Trigger gear is now tripped

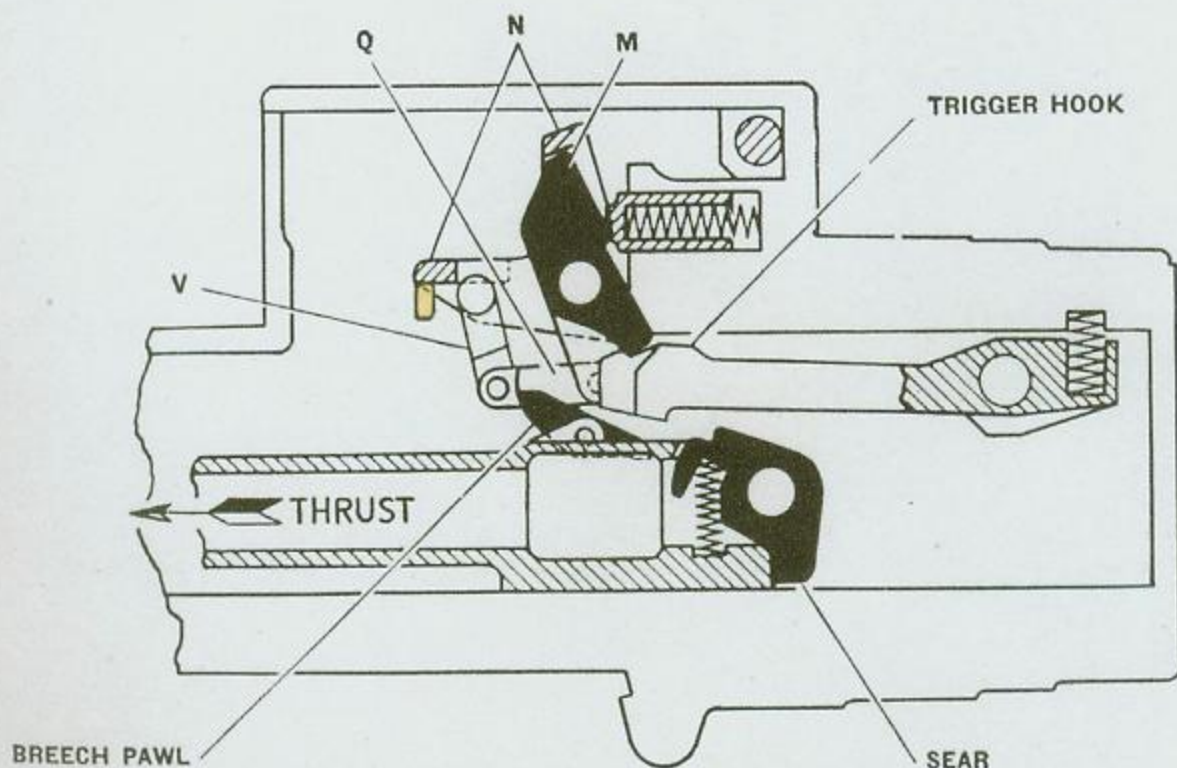

Figure 37—Interlock tripped, recoiling mass about to start counterrecoil and be held in cocked position by breech pawls engaging parallelogram bottom lever lugs

M—Parallelogram rear lever
N—Parallelogram top lever

Q—Parallelogram bottom levers
V—Parallelogram front lever

TRIGGER MECHANISM

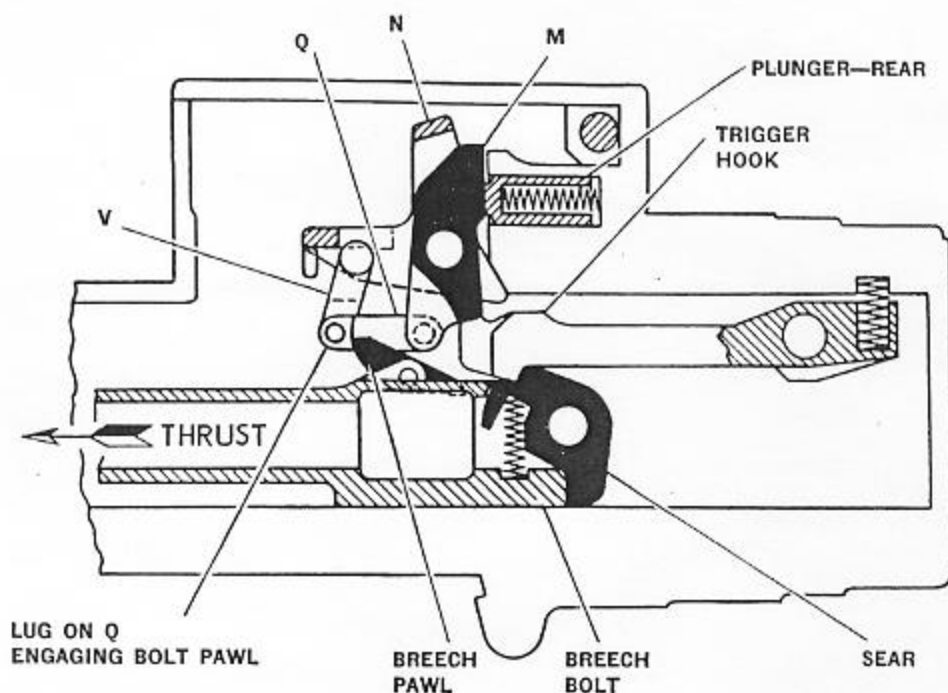

Figure 38—Recoiling mass held in a cocked position

M—Parallelogram rear lever
N—Parallelogram top lever

Q—Parallelogram bottom levers
V—Parallelogram front lever

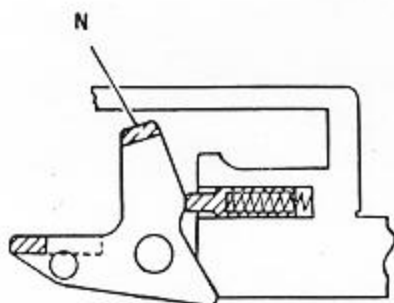

Figure 39—Action of spring plungers on parallelogram top lever

front portion of the magazine interlock gear is shown in Figure 33. It should be noted that the interlock lever (D) is fastened by its axis bolt (G) to the interlock carrier (F) and the interlock rod (K) is also fastened to the interlock carrier (F) by pin (J). The interlock carrier spring (C) acts rearward on the carrier (F) when the lever (D) is out of its catch recess (I). The interlock lever spring (H) acts on the lever (D) tending to keep the lever in its catch recess (I) and the front end upward.

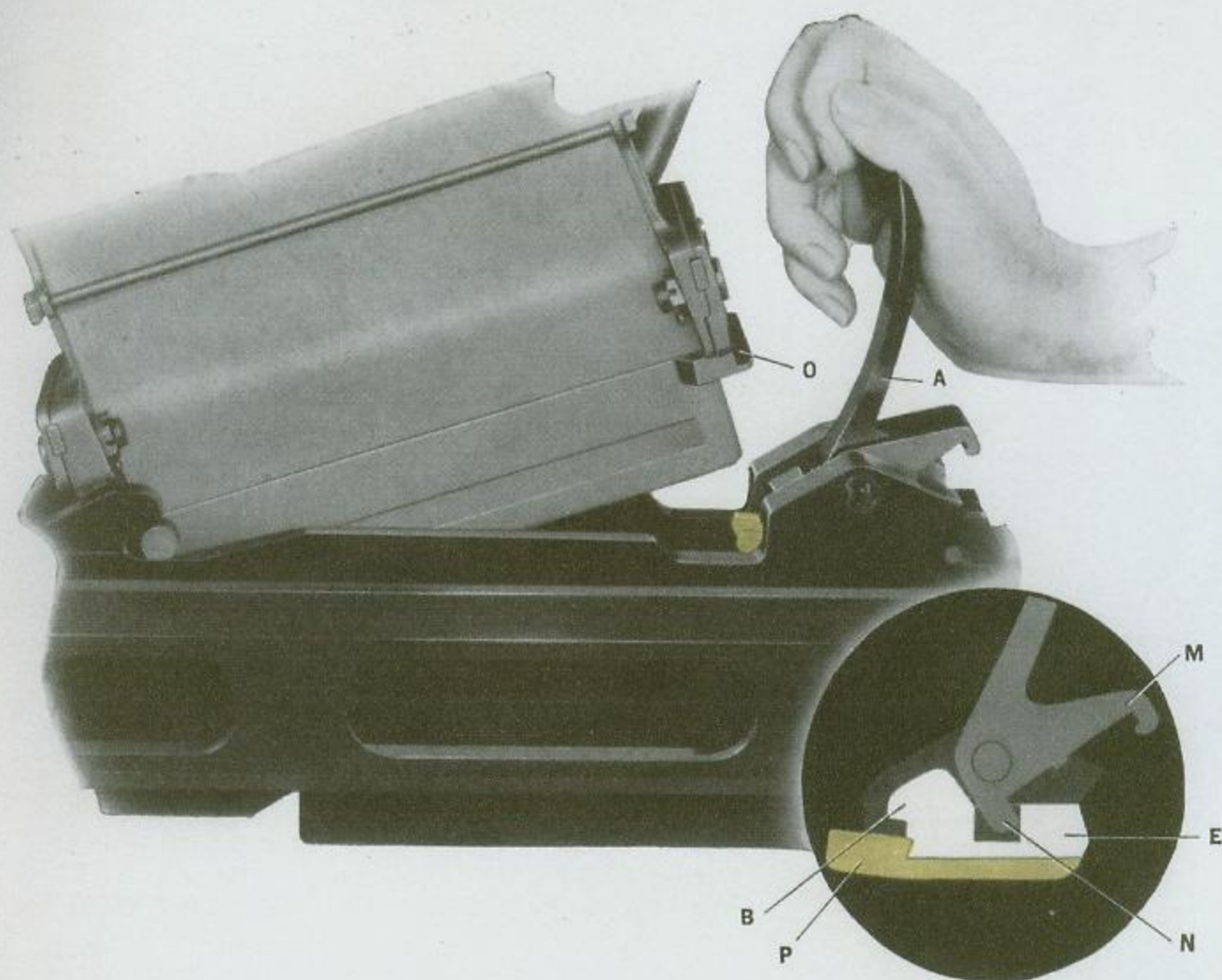

Figure 40—Unshipping a magazine—ejector moved to rear by hand pressure on catch lever and held to rear by catch

- | | |
|--|--|
| A—Magazine catch lever (OE-1043) | N—Front toe of magazine catch lever |
| B—Securing lug on ejector for magazine | O—Lug on magazine for locking by ejector |
| E—Ejector (OE-1045) | P—Magazine catch (OE-1046) |
| M—Rear toe of magazine catch lever | |

The loading power of the magazine is by a clock spring behind the cartridge feeder in the magazine. This feeder operates against the last round in the magazine. A detail description and illustration of the magazine operation is given on pages 64 and 65.

When the last round is fed into the gun, the cartridge feeder emerges at the mouth of the magazine, Figure 35. A bolt on the rear end of the cartridge feeder then bears down against the front end of the magazine interlock lever that is pivoted within the magazine interlock carrier and disengages it from the catch recess in the ejector. This leaves the magazine interlock carrier together with the magazine interlock lever free to move rearward within the ejector under the influence of the interlock carrier spring. As the carrier moves to the rear, it takes with it the magazine interlock rod. The rear end of the rod pushes against the magazine interlock fork, Figure 36, thus rotating the fork on its axis bolt. As the fork rotates, a part of

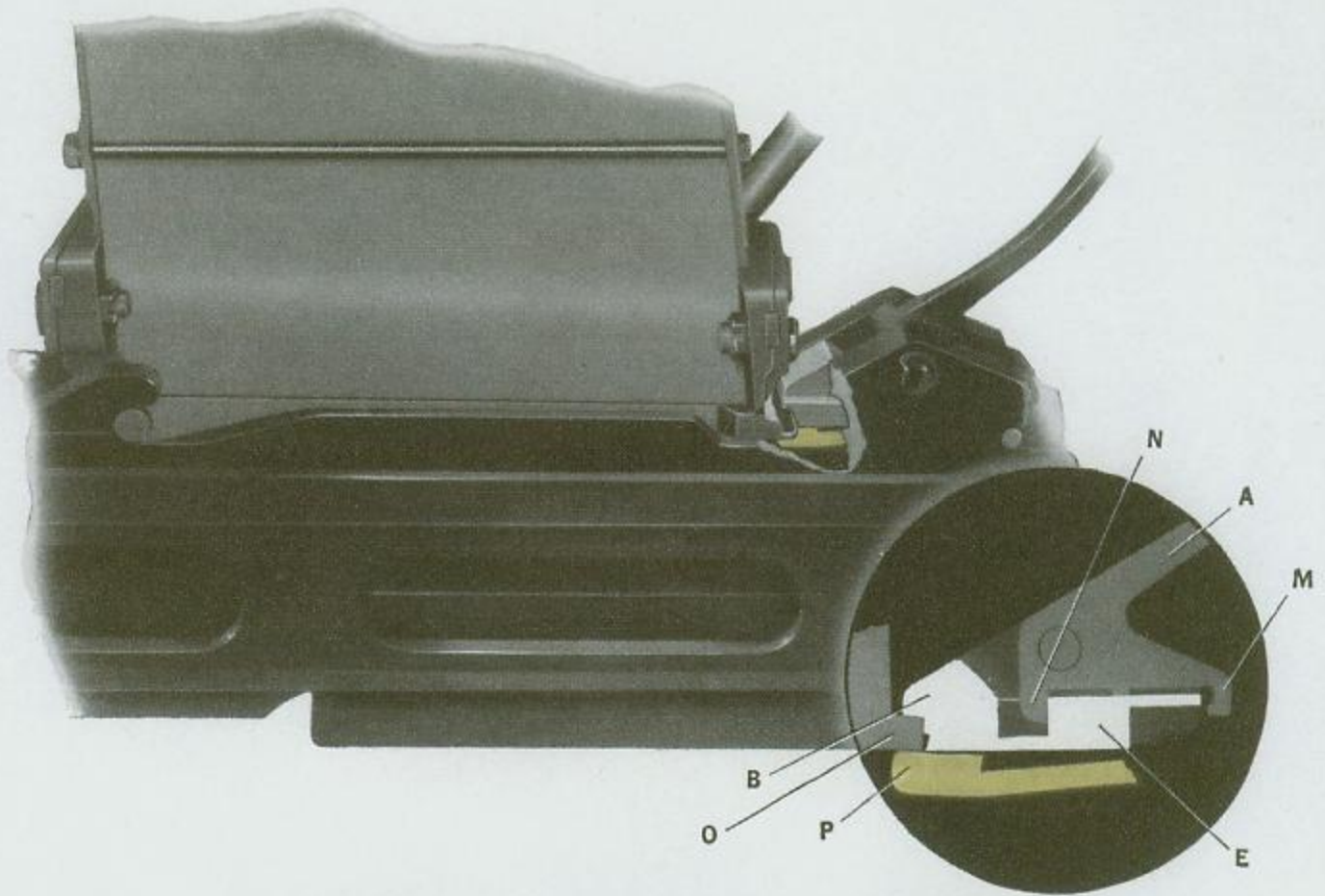

Figure 41—Magazine in shipped or firing position, showing catch down and ejector locking magazine in place

A—Magazine catch lever (OE-1043)
B—Securing lug on ejector for magazine
E—Ejector (OE-1045)
M—Rear toe of magazine catch lever

N—Front toe of magazine catch lever
O—Lug on magazine for locking by ejector
P—Magazine catch (OE-1046)

the fork presses against a bolt that bears in turn against the claw of the trigger pawl. The movement of this bolt then trips the trigger pawl disengaging it from the trigger crank permitting the trigger crank to drop. This lowers the front end of the parallelogram into the position shown in Figure 37. This brings the lug on the parallelogram bottom levers (Q) in line with the path of travel of the breech pawls on recoil and counter-recoil. As the breech block recoils the breech pawls slide under and past the lugs on parallelogram bottom levers (Q) and on the counterrecoil engage these lugs, and lock the trigger hook as shown in Figure 38.

MAGAZINE INTERLOCK WITHDRAWAL WHEN UNSHIPING MAGAZINE

The action of moving the magazine catch lever toward the muzzle to free the empty magazine for unshipping, Figure 40, forces the ejector to the rear so that it overtakes the magazine interlock carrier. This allows the magazine interlock lever, pivoted within the magazine interlock carrier, to be forced by its spring into engagement again with the recess in the ejector thus locking the interlock carrier to the ejector once more. This movement of the ejector compresses the catch spring, Figure 42, moving the magazine catch about its pivot causing its front ends to contact the front end of the ejector thus holding the ejector in its rear position.

TRIGGER MECHANISM

When shipping a new magazine a projection at the mouth presses down the forward ends of the catch, Figure 41, leaving the ejector free to move forward because of the pressure of magazine interlock catch spring, Figure 42, and lock the magazine to the gun as previously described under heading "Magazine Catch Gear and Ejector" page 29. In the course of this action of locking the magazine when the ejector moves forward the magazine interlock carrier is carried with it because it is engaged in the catch recess in the ejector, Figure 42, and the magazine interlock rod is also moved forward because it is fastened to the carrier. This forward movement of the magazine interlock rod frees it from the magazine interlock fork, Figure 42.

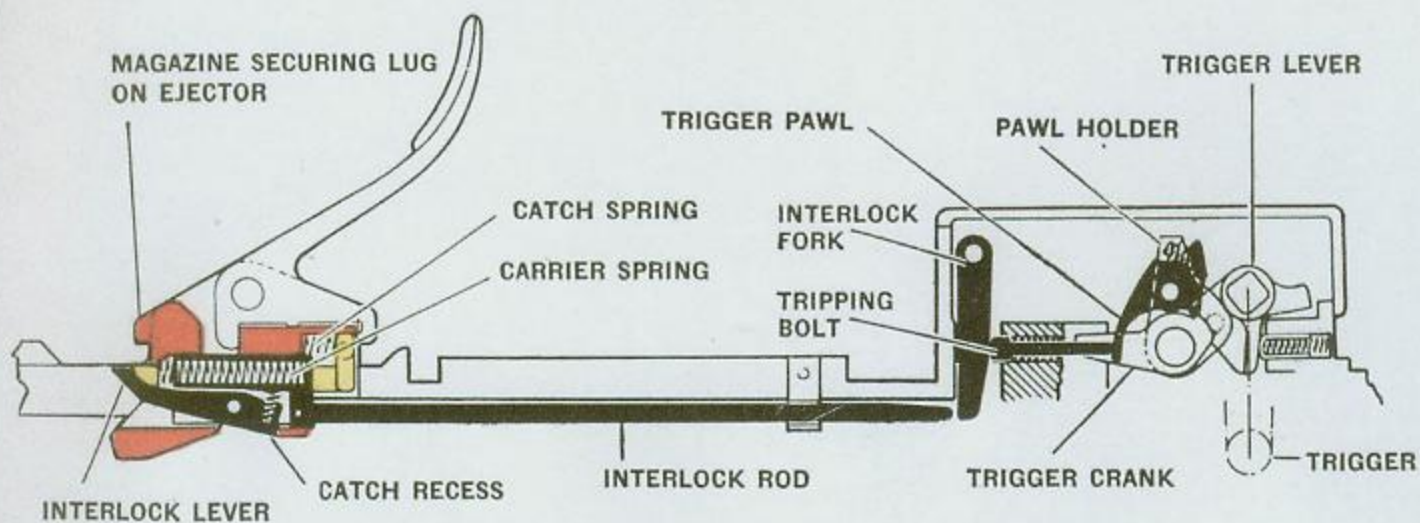

Figure 42—Magazine interlock gear in firing position

The magazine interlock fork and the trigger pawl tripping bolt then return to their original positions, Figure 42, because of the pressure of the trigger pawl tripping bolt spring, Figure 36. The trigger pawl, Figure 42, is thus left free to re-engage itself with the trigger crank because of the pressure of the compressed spring between the trigger pawl holder and trigger pawl.

NOTE—THE MAGAZINE IS HELD LOCKED TO THE GUN DURING THE PERIOD OF EJECTION OF THE CARTRIDGE. When the breech bolt mass is recoiling, the impact of the fired cartridge case against the ejector slides the ejector rearward into engagement with the recess (M), Figure 41, of the magazine catch lever thereby preventing it from rising. Thus the magazine is held locked to the gun during the period of the ejection of the cartridge.

NOTES

NOTES

RECOILING PARTS AND BUFFERS

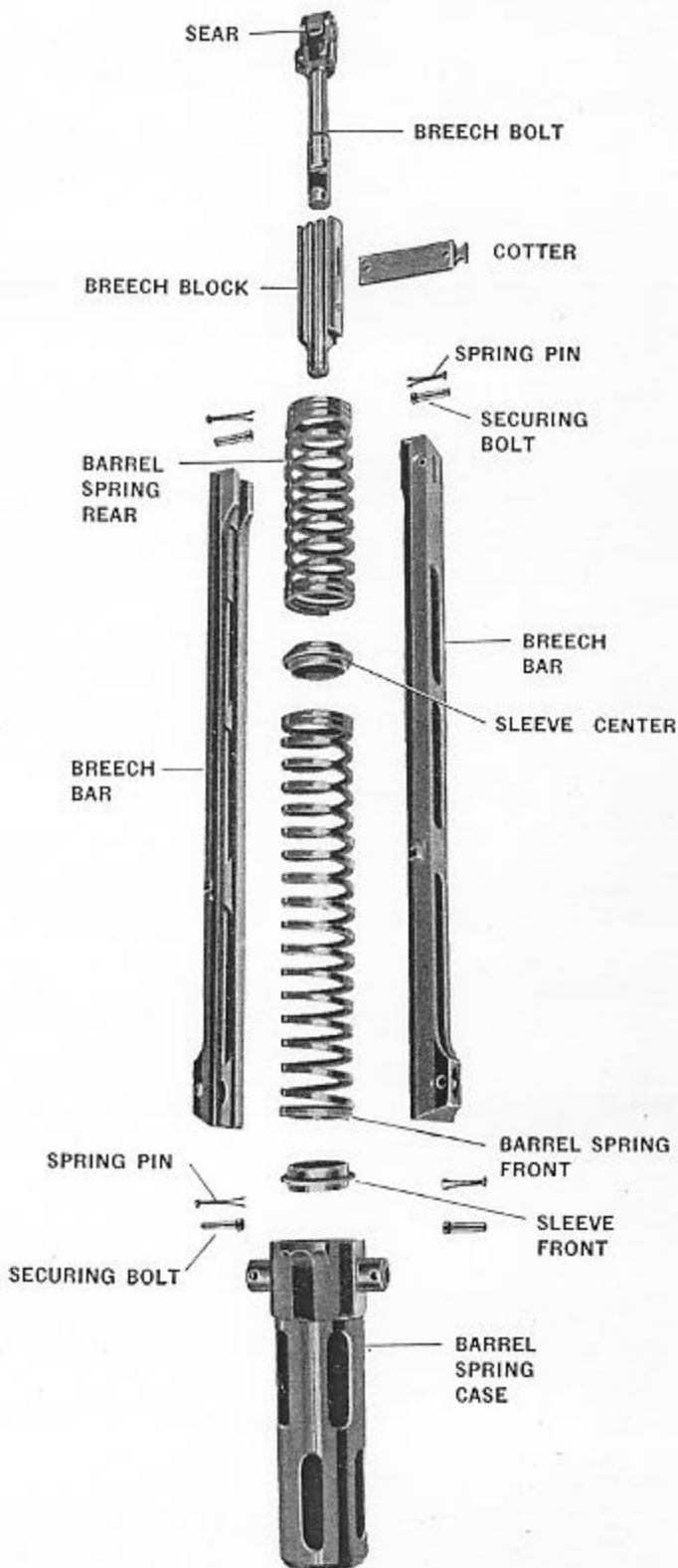

Figure 43—Recoiling Parts

Chapter 5

COMPONENTS

The principal components of the recoiling group illustrated in Figure 43, are:

1. Breech block (OE-1304), carrying the hammer (OE-1308), striker pin (OE-1307) and breech face piece (OE-1305).
2. Breech bolt (OE-1315), carrying the sear (OE-1317).
3. Breech bars, left and right (OE-1310 and OE-1311), connecting the breech block (OE-1304) to the barrel spring case (OE-1102)*.
4. Breech bolt cotter and securing bolts holding recoil parts together, as follows:
 - (a) Breech bolt cotter (OE-1316), holds breech block (OE-1304) to breech bolt (OE-1315).
 - (b) Securing bolts (OE-1323) and spring pins (OE-1324)**, secure barrel spring case to breech bars.
 - (c) Securing bolts (OE-1323) and spring pins (OE-1324)**, secure breech bars to breech bolt cotter.
5. Barrel spring case (OE-1102)*, mounted on the forward portion of the barrel.
6. Barrel springs (OE-1320 and OE-1321)***, mounted on the center portion of barrel, between the barrel spring case and the breech casing.

*Later model guns use a new barrel spring case with which front sleeve (OE-1318) is not used. See Page 147.

**Later model guns use a wire spring type securing bolt retainer (299666-4). See Page 135.

***Later model guns use new round wire barrel springs numbers (367533-2) front and (367533-1) rear. See Page 148.

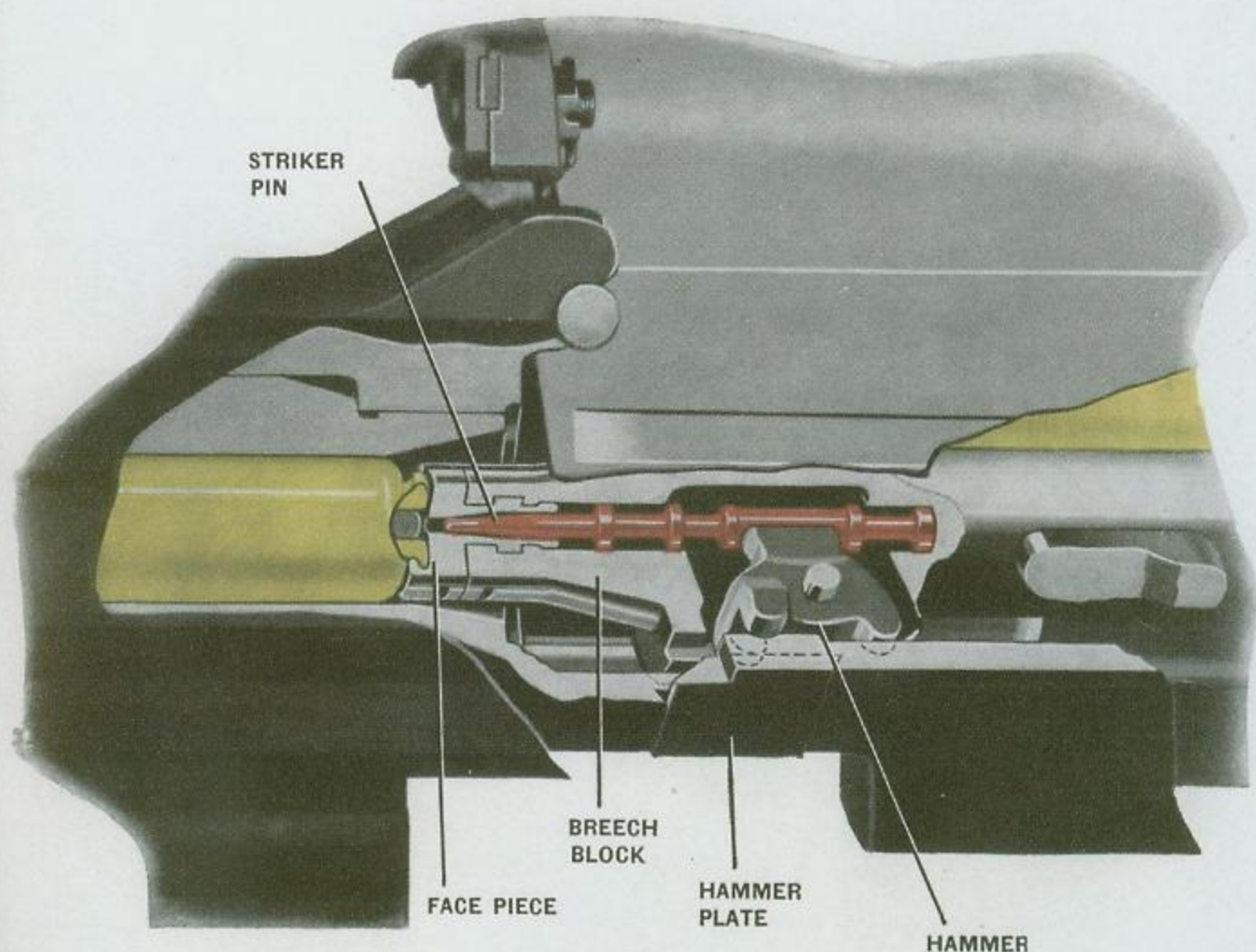

Figure 44—Breech bolt traveling forward with cartridge
Hammer holding striker pin to rear

RECOILING PARTS AND BUFFERS

In addition to the barrel springs (OE-1320 and OE-1321), Figure 43, there are two sets of buffer springs. A set of twelve (OE-1327) are mounted in the front end of the gun casing to cushion the last inch or so of recoil, Figure 46. A set of fifteen (OE-1326) in the trigger casing cushions the shock on the trigger mechanism when the trigger hook stops the gun in the cocked position, Figure 24.

STRIKER GEAR

The action of the striker gear is shown in Figures 44 and 45 showing the striker pin being held to rear when the breech bolt is traveling forward; the hammer imparting a blow to the striker pin and the striker pin being withdrawn by the hammer.

NOTE—The striker pin reaches its full firing travel by momentum and not by a direct thrust all the way by the hammer.

In order to understand the action of the hammer it should be noted in Figures 44 and 45 that the front toes and rear toe are positioned out of line with each other. There are two front toes, one on each side of the hammer. The rear toe is an extension of the center part of the hammer. The upper part of the hammer rests in, and operates, the striker pin. The hammer plate is secured to the breech casing and has a center cam surface, to operate the rear toe of the hammer and impart a thrust on the striker pin. Momentum carries the striker forward, thus firing the cartridge. See Figure 45. The hammer plate has two other cam surfaces, one on each side, to operate the hammer front toes and thus withdraw the striker pin from the

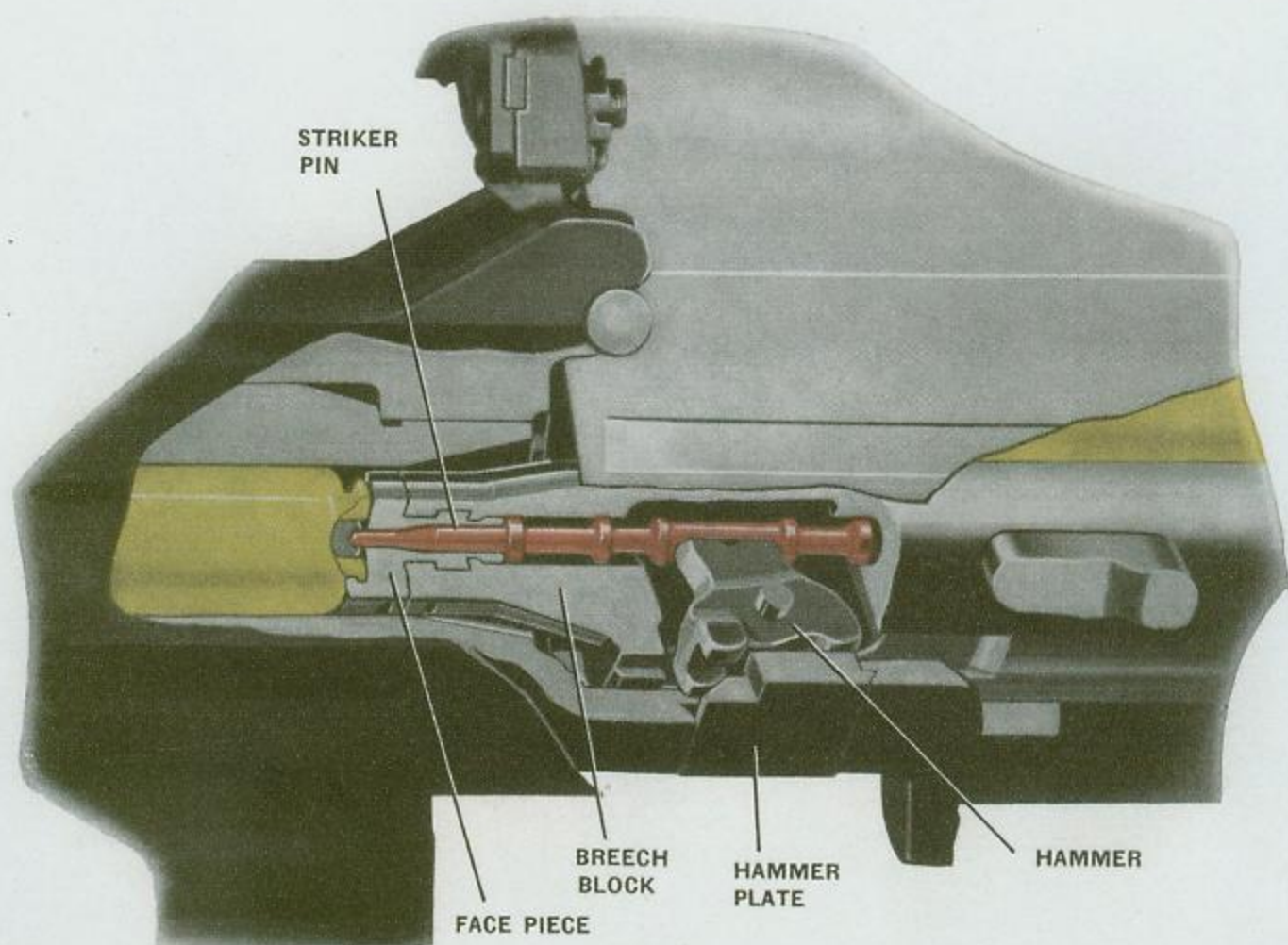

Figure 45—Breech bolt has carried cartridge into position to be fired. Rear hammer toe on hammer plate; front hammer toes in recess in breech casing

RECOILING PARTS AND BUFFERS

fired cartridge. The hammer plate cam surfaces are arranged so that the front toes are clear when the rear toe is operating, and the reverse is also true.

The three conditions of the operation of the striker gear are:

1. Breech block is traveling forward; Figure 44, it has picked up a cartridge, but has not quite reached the firing chamber. All three hammer toes are riding against the side of the breech casing, thereby holding the striker pin to the rear. The rear toe is about to strike the rear end of the center cam surface of the hammer plate.

2. The breech block has reached the end of its travel, Figure 45. The cartridge is being fired. The rear toe of the hammer is riding on the center cam surface of the hammer plate, causing the hammer to rotate forward. The hammer has driven the striker pin fully forward penetrating the primer of the cartridge. The front toes have entered a cutaway recess in the breech casing.

NOTE—THE STRIKER PIN SHOULD PROTRUDE 0.045 INCH TO 0.070 INCH FROM THE BREECH BOLT FACE PIECE WHEN THE STRIKER PIN IS FULLY FORWARD. See Maintenance Instructions on Page 142.

3. The breech block has started on recoil carrying with it the fired cartridge, Figure 44. The front toes have ridden up the front slope of the hammer plate causing the hammer to rotate rearward. The hammer has retracted the striker pin from the fired cartridge.

BREECH BLOCK

The breech block is connected to the breech bolt by the same cotter that connects the breech bolt to the breech bars. See Figure 43. The purpose of the breech bolt is to extend the breech block to the rear, in order to contact the trigger group. The breech bolt carries the recoil sear at the rear on an axis bolt. The right and left breech pawls are near the rear of the breech bolt. The recoil sear and breech pawls work with the trigger group as described on Page 42 and illustrated on Page 43.

The breech block face piece, Figures 44 and 45, is mounted in the front end of the breech block. It is retained by a shoulder that fits into a recess machined in the breech block, and is locked in place by a leaf spring. A hole is drilled in the center of the breech block face piece for the forward end of the striker pin. A cartridge carrier lip is integral with the front of the face piece, to carry the rear end of the cartridge case.

BREECH BARS

The breech bars are connected at the rear by the breech bolt cotter that passes through the breech block and its extension, the breech bolt, Figure 43. The breech bars are connected at the front to trunnions formed on the barrel spring casing. The trunnions fit in holes in the breech bars. Tubular securing bolts that are secured by two-legged spring pins fasten the breech bars to the barrel spring casing trunnions at the front, and to the breech bolt cotter at the rear. See Figure 43. New type breech bar securing bolt retainers (299666-4) made of round wire are now used. Instructions covering their installation and removal may be found on Page 135.

The right and left breech bars have hardened stop plates that contact the double loading stop whenever a portion of a torn cartridge case remains in the firing chamber under the double loading stop pin. See Page 34 for description and illustration of "Double Loading Stop."

BARREL SPRINGS AND CASE

There are two barrel springs; a long front one in the barrel spring case and a short rear one, with a center sleeve between them, See Figure 43. These springs are wound in opposite directions so as to prevent

RECOILING PARTS AND BUFFERS

twist on the spring casing and on the breech bars that might be caused by twisting of a single spring. The purpose of these springs is to absorb the rearward momentum of the recoiling parts, and to return these parts to their forward position.

NOTE—The compression on the rectangular barrel springs is 72 pounds and on the round wire barrel springs 130 pounds when the recoiling parts are in their fully forward position. The compression amounts to 576 pounds on the rectangular wire barrel springs and 396 pounds on the round wire springs when the buffer strikes the breech casing.

The casing for the barrel springs carries the recoiling end of these springs, Figure 43. A barrel spring front sleeve fits into the front end of the casing and is the front seat for the springs. A barrel spring center sleeve is the intermediate support for the barrel springs and is located between the two springs. It is a loose fit on the barrel. A barrel spring seating ring that is locked in the front end of the breech casing is the rear seat for the barrel springs. See Figure 46. The recoil buffer springs, described below, assist the barrel springs.

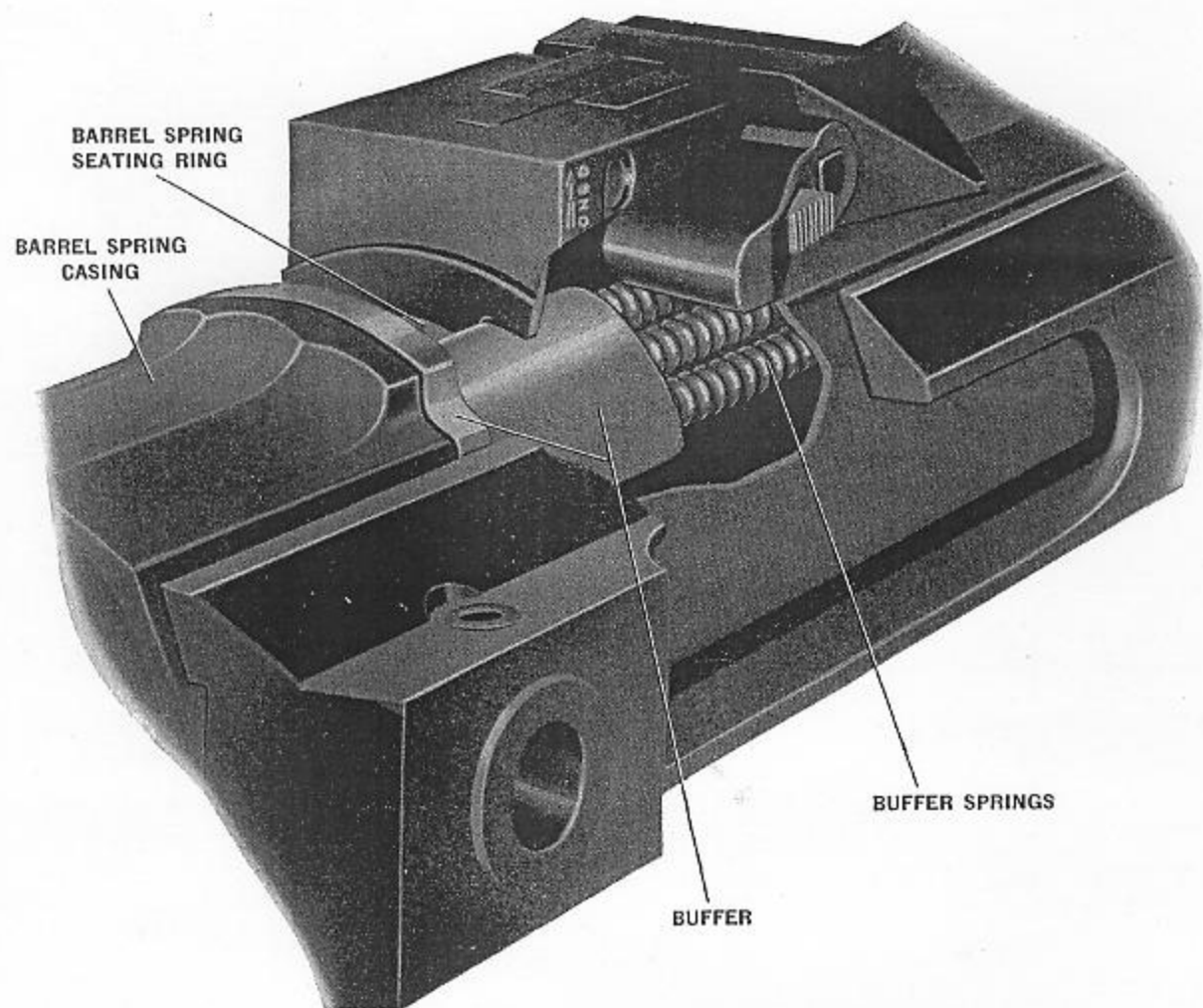

Figure 46—Recoil Buffer Springs

RECOILING PARTS AND BUFFERS

RECOIL BUFFER SPRINGS

A set of twelve buffer springs are mounted in the forward end of the breech casing, Figure 46.

These recoil buffer springs assist the barrel springs to absorb the recoil and also assist the breech block mass in counterrecoiling. They operate only during the last inch of recoil and during the first inch of counterrecoil. The total compression of the twelve buffer springs, plus the barrel springs at full metal to metal recoil, is 3084 pounds on the rectangular wire type and 2616 pounds on the round wire type barrel and buffer springs.

NOTE—The gun will continue firing with recoil buffer springs broken, but it is inadvisable to allow this except in action, as the recoil tends to become metal to metal. Parts are then liable to be damaged and THE GUN BECOMES LESS STEADY FOR LAYING AND THE RATE OF FIRE DROPS. See Maintenance Instructions Pages 112 and 113.

A recoil buffer, Figure 46, retains the buffer springs in the breech casing, and the rear end of the barrel spring casing contacts this buffer during the last inch of recoil, compressing the springs. The buffer is held in the breech casing by the barrel spring seating ring. See Figure 46.

TRIGGER BUFFER SPRINGS

One of the duties of the trigger group is to intercept the recoiling mechanism, in order to keep the gun cocked whenever the trigger is released during firing, and, as the recoiling mass is moving forward at high speed, there is a severe shock at the moment of interception. The trigger buffer springs cushion this shock, thereby protecting the sear and trigger hook.

There are fifteen trigger buffer springs (R), Figure 24, mounted in the trigger casing (C), Figure 24.

This trigger casing also carries the trigger hook and the trigger parallelogram levers, and is locked in the breech casing by the hand grip mounting piece. The trigger casing is free to move forward a short distance by compressing the trigger buffer springs against the breech casing. This cushions the interception of the recoiling mass.

NOTES

NOTES

Chapter 6

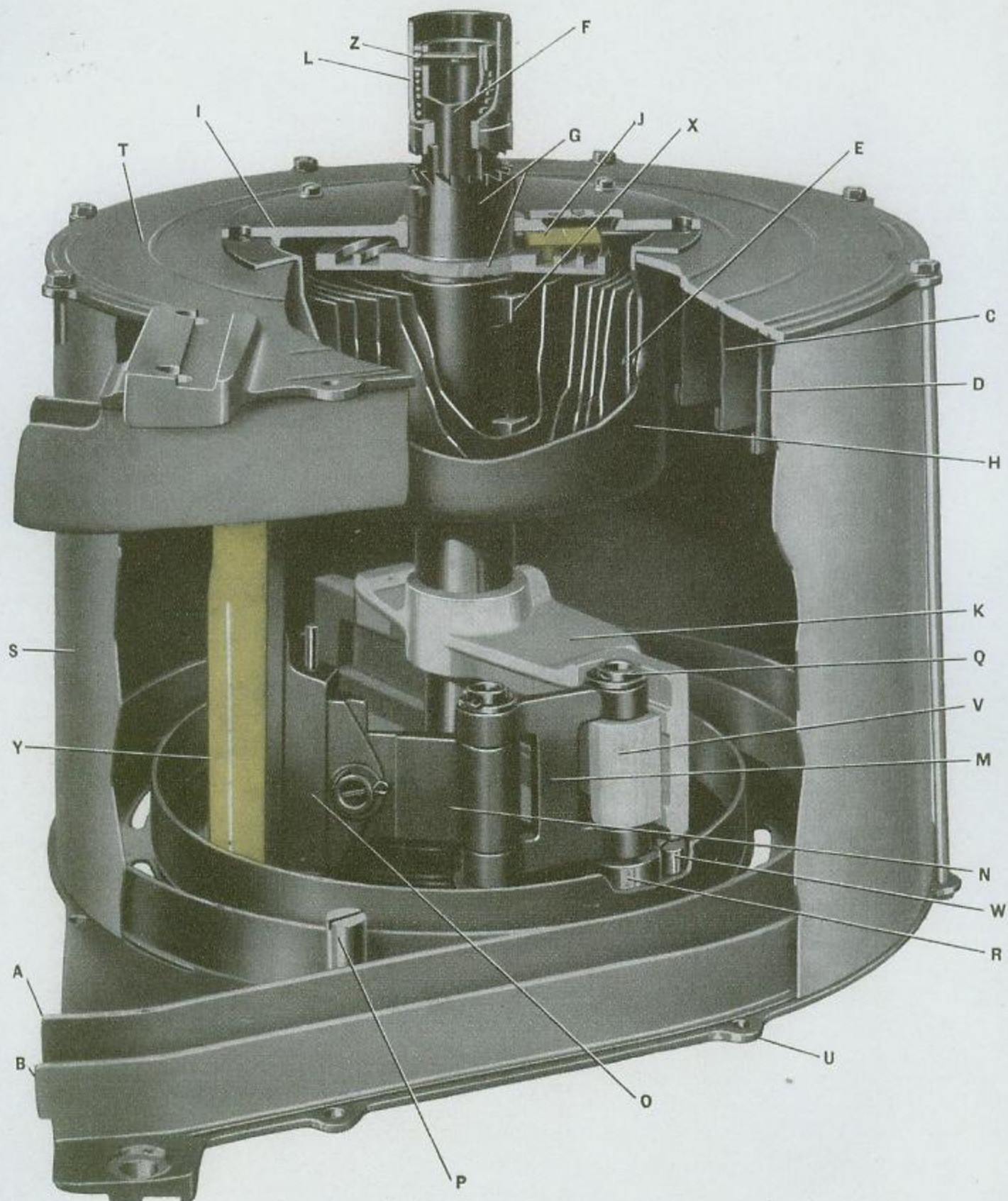

Figure 47—Magazine Internal Parts

MAGAZINE OPERATION

The magazine consists of a cylindrical drum containing 60 rounds of ammunition that are driven around spirals, see A, B, C and D, Figure 48, inside the drum, by a clock spring (E) that is hand wound from outside the magazine. The tension of the spring can be adjusted.

MAGAZINE FEED ACTION

The feed system maintains a pressure on the innermost round, by means of a wound clock spring (E), Figure 47, that is always endeavoring to push the rounds around the spirals (A, B, C and D), and out of the magazine mouthpiece. The lips of the magazine mouthpiece are partly closed so that a round can pass through it only by being pushed out longitudinally at a right angle to the direction of the feed drive, a gap being cut in the front, or muzzle end, of the mouthpiece to allow the rounds to slide in or out.

MAGAZINE SPRING

The pressure on the innermost round is from a clock spring (E), Figure 47, that is housed in the magazine casing. The outer end of the spring is held to a spring case by a securing pin at (E). The spring case is bolted to the magazine casing by screws, thus fixing the outer end of the magazine clock spring. The inner end of the spring is hooked on the spring axis (G) at point (X), and any tension on the spring (E) tends to turn this spring axis (G). This spring axis (G) can either rotate freely on the mainshaft (F), or can be coupled to it by a spring coupling sleeve (L) having ratchet teeth. When this coupling sleeve (L) is in engagement the tension of the clock spring (E) is transmitted to the main shaft (F) tending to rotate it.

MAGAZINE CARTRIDGE FEEDER

The feed block (K) driven by the main shaft carries the feed arm (V) which can slide through the feed block to the radius of any point in the spiral path (A, B, C and D). The cartridge feeder link (M) is pinned to the feed arm (V) and to the feed head (N) by two articulating bolts (Q). These two articulating bolts have rollers (R) that guide the feed system around the spiral. The cartridge feeder (O) swivels on the feed head (N) pushing the cartridge (Y) around the spiral.

MAGAZINE SPRING TENSION LIMITS

The spring axis (G) has a spiral groove cut on its flange, and this spiral groove actuates an indicator block (J), Figure 47, that slides in a radial direction in the cover plate (I). This block (J) is an indicator of the amount of tension in the spring (E), and it also stops the winding or unwinding of the spring when the end of the spring axis spiral groove is reached.

NOTE—This block (I) does NOT indicate how many rounds of ammunition are in the magazine, but shows the amount of tension in the magazine clock spring (E). THE ZERO POSITION OF THE INDICATOR BLOCK (J) SHOWS THAT IT HAS REACHED THE END OF THE SPRING AXIS GROOVE AND IS HOLDING WHATEVER TENSION

The following are the references on Figure 47:

A—Magazine spiral guide—rear—inner (OE-1543)	N—Feed head (OE-1563)
B—Magazine spiral guide—rear—outer (OE-1542)	O—Cartridge feeder (OE-1567)
C—Magazine spiral guide—front—inner (OE-1540)	P—Stop bolt—long (OE-1576)
D—Magazine spiral guide—front—outer (OE-1539)	Q—Articulating bolt (OE-1564)
E—Spring (OE-1572)	R—Articulating bolt roller (OE-1565)
F—Main shaft (OE-1584)	S—Casing (OE-1544)
G—Spring axis (OE-1582)	T—Front plate (OE-1537)
H—Spring case (OE-1570)	U—Rear plate (OE-1538)
I—Cover plate (OE-1581)	V—Feeder arm (OE-1561)
J—Indicator block (OE-1583)	W—Stop bolt—short (OE-1577)
K—Feed block (OE-1549)	X—Lugs where spring fastens to spring axis
L—Coupling sleeve (OE-1529)	Y—Cartridge
M—Cartridge feeder link (OE-1579)	Z—Ratchet cross pin (OE-1587)

REMAINS IN THE CLOCK SPRING (E). IN THIS POSITION THE RATCHET TEETH OF THE COUPLING SLEEVE (L) CAN BE DISENGAGED FROM THE MAIN SHAFT (F) THUS FREEING IT FROM ALL SPRING DRIVE.

The last round of ammunition should be fed into the magazine mouthpiece just before the indicator block (J) reaches the end of the spring axis groove.

NOTE—The amount of residual tension in the magazine spring is of importance as it indicates how much drive will be imparted to feeding the last round.

Instructions for checking and adjusting the magazine spring tension are given on Page 71.

LOADING THE MAGAZINE

NOTE—The last two rounds loaded in each magazine should have blind loaded projectiles. This practice is generally adopted to obviate the danger of firing of an H. E. projectile through the muzzle cover.

1. Place magazine in the loading frame (OE-1591) as shown in Figure 48.

NOTE—See if the indicator block is at zero, and if it is not, the spring tension must be relieved as instructed on Page 72.

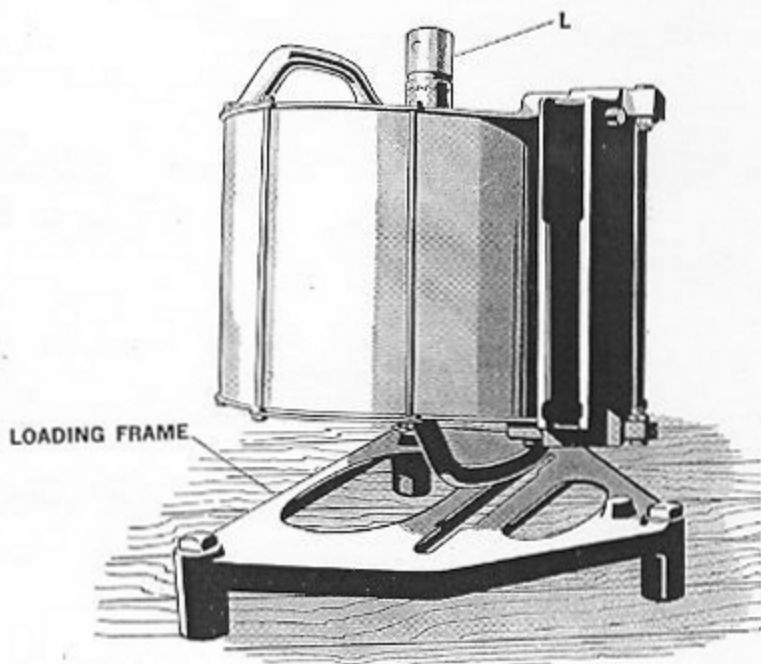

Figure 48—Placing magazine in loading frame, coupling (L) down

2. Pull out the coupling sleeve (L), Figure 50, as far as possible, and while holding it out, turn it to a point where, when released, it is on the lugs of the main shaft and will not snap down and engage the ratchet teeth again, Figure 51. Turning the coupling sleeve about an eighth turn, should hold it disengaged.

MAGAZINE

3. Place the loading lever on the end of the main shaft, as shown in Figure 52. This will permit the feed axis to be revolved and thereby rotate the cartridge feeder.
4. Revolve the loading lever clockwise, until the cartridge feeder is in the magazine mouth.

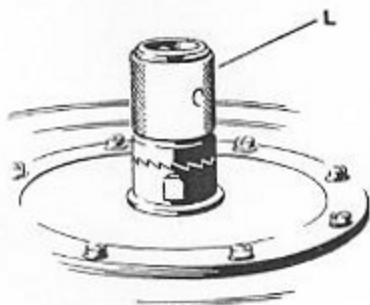

Figure 49

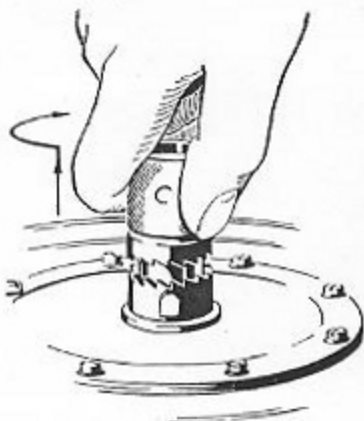

Figure 50

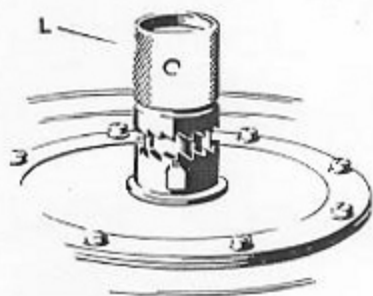

Figure 51

COUPLING SLEEVE POSITIONS

5. Remove loading lever from coupling sleeve, leaving the coupling sleeve (L) in its pulled out position, as in Figure 51.
6. Push, by hand, through the magazine opening against the cartridge feeder, and move it back just

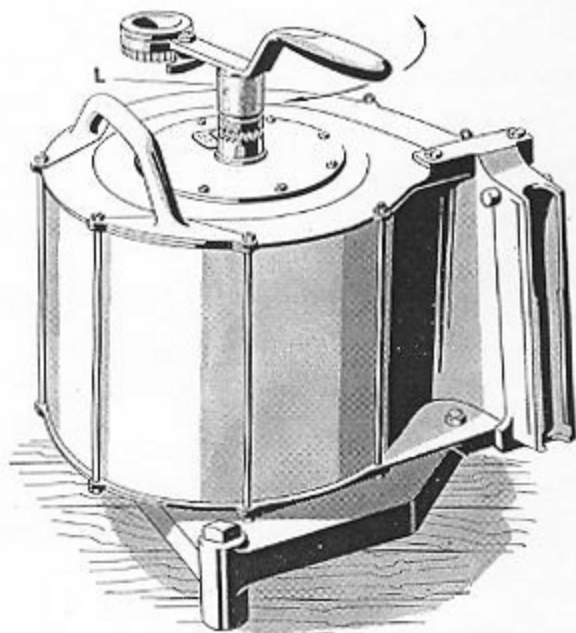

Figure 52—Magazine loading lever on main shaft (feed axis)

far enough to leave space for the insertion of one or two cartridges. NEVER LEAVE SPACE FOR MORE THAN TWO CARTRIDGES.

7. After a cartridge is inserted, press by hand against it, moving it back far enough to insert one or two cartridges. See Figure 53. Continue inserting cartridges until the magazine is full. Capacity of magazine is 60 cartridges.

Instead of pressing the cartridge by hand, magazine loading tool (299712-7), illustrated in Figure 54, can be used to better advantage.

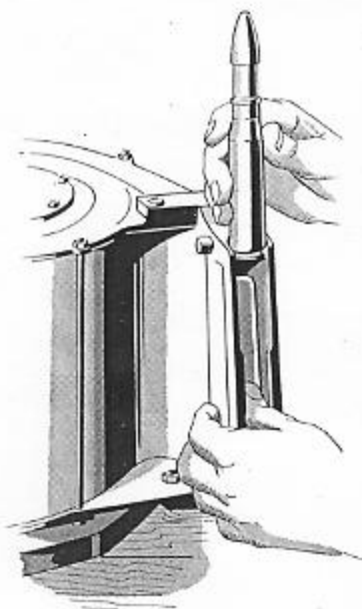

Figure 53—Hold feeder back just far enough to insert one cartridge

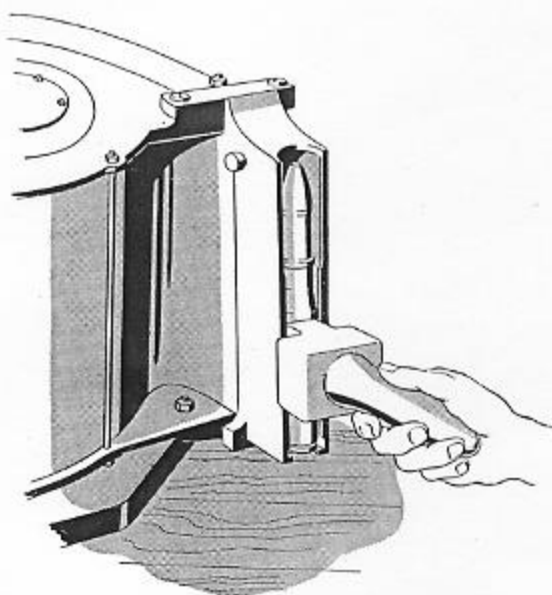

Figure 54—Loading the magazine with loading tool (299712-7)

If desired, it can be made on shipboard by cutting it out of a piece of hardwood to the dimensions shown in Figure 55.

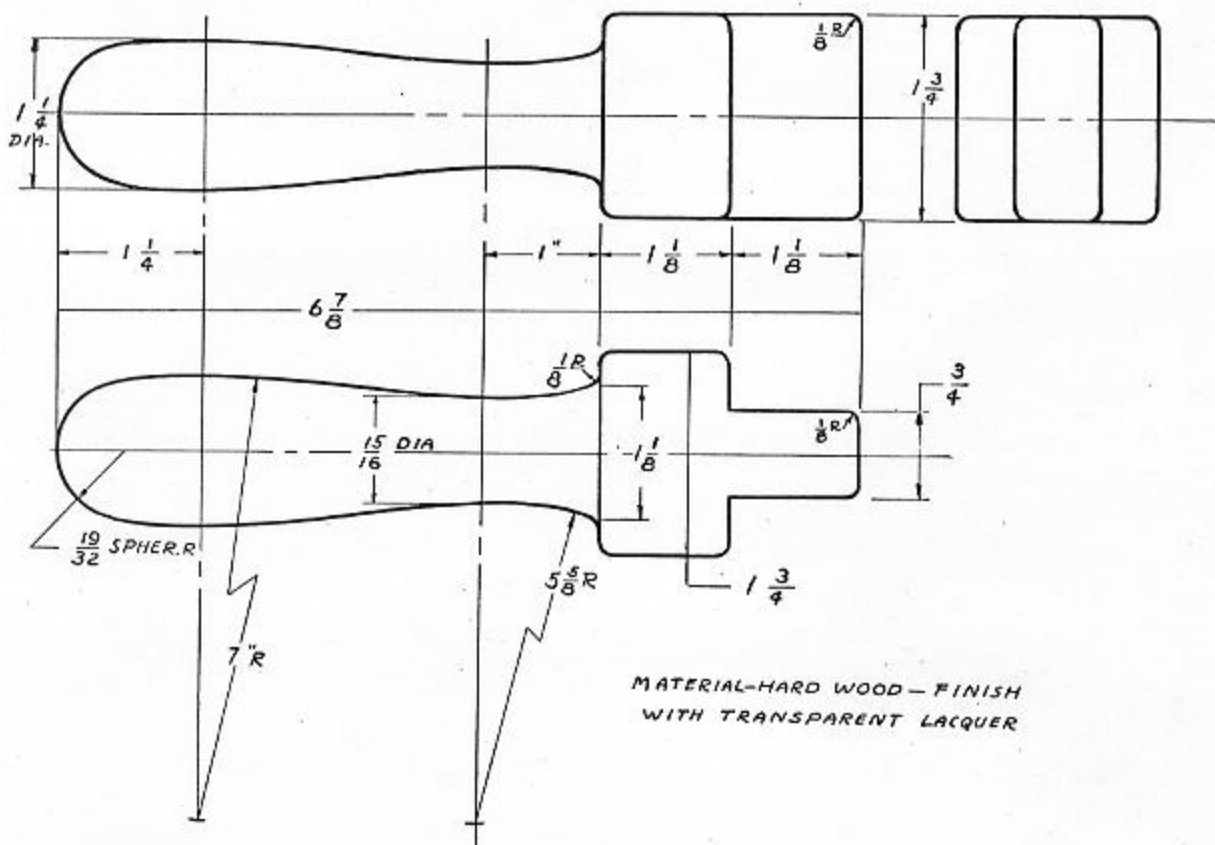

Figure 55—Drawing of loading tool (299712-2)

Magazine loading tool assembly (367524), illustrated in Figure 56, will be found helpful in rapidly loading cartridges into the magazine. To use the tool, clamp it over the mouthpiece of the magazine. Pull the handle backward and feed the cartridges into the mouthpiece, one at a time. As the cartridge is placed in position, push the handle forward and then pull backward. Repeat the operation until the magazine is loaded.

NOTE—It is essential that all cartridges be pushed all the way down to the bottom of the magazine mouth so that their bases are in alignment and firmly seated on the magazine rear plate, as shown in Figure 58. This is important because the breech block moves very rapidly and the magazine must feed the cartridge to it properly, so that the face piece can readily pick up the cartridge.

CAUTION—Great care should be taken not to push the cartridges and feeder a further distance than is necessary for the insertion of TWO cartridges. If the cartridges with the cartridge feeder are pushed in too far, they might become upset, and jam. A jammed magazine can be caused by pushing the feeder back too far by hand, or by using the

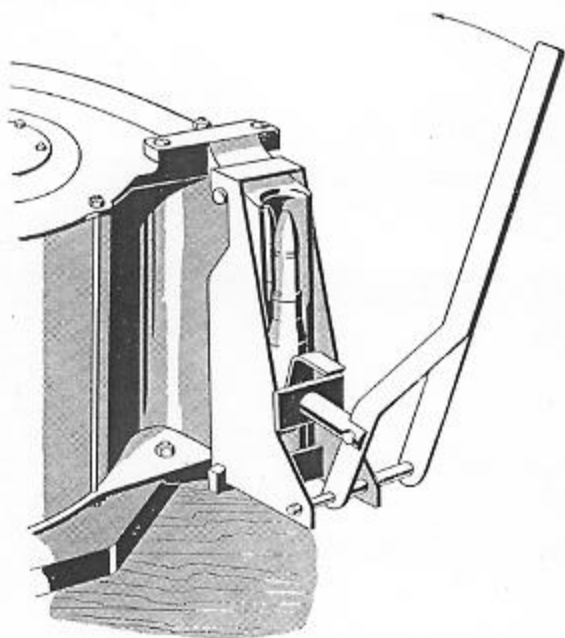

Figure 56—Loading the Magazine with loading tool assembly (367524)

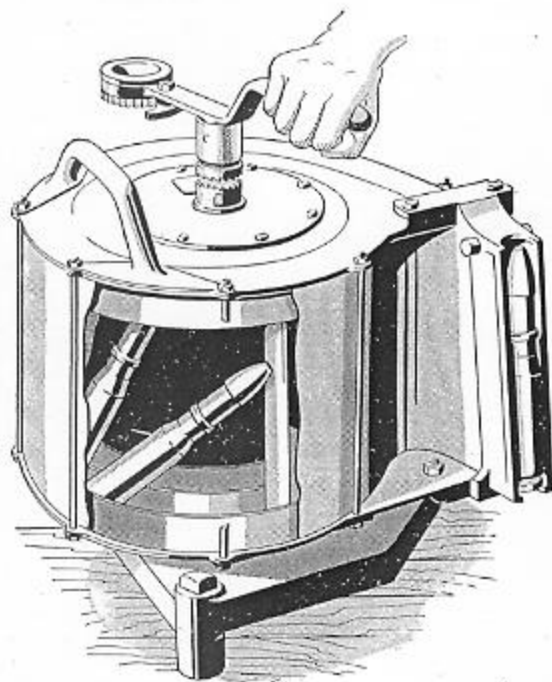

Figure 57—Magazine jammed because the cartridge feeder has been pushed back too far by the loading lever on the feed axis

loading lever on the feed axis, as shown in Figure 57. IF THIS HAPPENS IT IS NECESSARY TO DISMANTLE THE MAGAZINE TO CLEAR THE JAM.

It is sometimes impossible to push by hand a number of cartridges back into the magazine in order to make room for more, and this is particularly true toward the end of the loading of the magazine. When this condition occurs, use the loading lever as shown in Figure 52. Rotate the loading lever counter-clockwise very slightly for a distance necessary for the insertion of one or NEVER OVER TWO cartridges.

CAUTION—IF THE LOADING LEVER IS ROTATED FARTHER THAN THIS, THE CARTRIDGES WOULD HAVE ROOM TO FALL INTO AN OBLIQUE POSITION, SEE FIGURE 57, THEREBY PREVENTING FURTHER LOADING, AND MAKING IT NECESSARY TO DISMANTLE THE MAGAZINE AND CLEAR THE JAM.

8. When the magazine has been correctly filled to capacity (60 rounds), the coupling sleeve must be revolved by hand until it drops into engagement with the ratchet teeth as shown in Figure 49.

NOTE—THE MAGAZINE CLOCK SPRING MUST THEN BE EITHER COMPLETELY, OR SLIGHTLY, TENSIONED AS INSTRUCTED IN THE FOLLOWING:

COMPLETELY TENSIONING A MAGAZINE SPRING.

9. When the loaded magazine is to be used **immediately**, the spring is tensioned completely in the loading frame. Place the loading lever on the spring axis, as shown in Figure 58. Revolve the loading lever counter-clockwise. Continue revolving the loading lever until a stop becomes distinctly noticeable. This indicates that the clock spring is completely tensioned. Remove the loading lever. Remove the loaded magazine from the loading frame and install on a gun.

DO NOT STORE A FULLY TENSIONED MAGAZINE, BECAUSE OF THE UNNECESSARY STRAIN ON THE WOUND CLOCK SPRING.

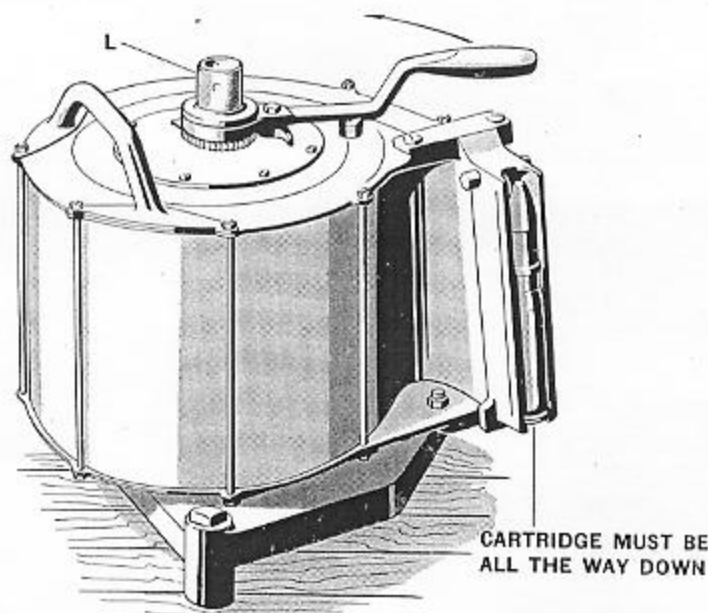

Figure 58—Tensioning the Magazine Spring

SPRING TENSION INDICATOR

The indicator scale on the front cover of the magazine shows "0," "15," "30," "45" and "60" and these figures are a measure of the magazine spring tension. Magazines are given either a partial spring tensioning when being stored for future use, or a complete tensioning when being used immediately. The amount of spring tensioning will depend upon how many cartridges there are in the magazine, as for example, a load of 30 or 45 cartridges requires a different spring tension than a full load of 60 rounds.

Partial tensioning of a magazine for storage purposes requires only a slight spring pressure, and the number of cartridges in the magazine makes no difference.

In the case of a magazine completely filled to its capacity of 60 rounds, and fully tensioned, the indicator will read "60."

In case the magazine has a partial load of cartridges, then the spring is tensioned according to the load in the following manner: There are openings in the back plate of the magazine through which the rear ends of the cartridges are visible. **Tension the spring for ten more cartridges than there are in the magazine.**

NOTE—Hold the coupling sleeve (L), Figure 58, with the fingers to prevent its turning when tensioning the spring on a partly loaded magazine. If it is permitted to turn, the cartridge feeder will be backed away from the cartridges and a jam may result.

SLIGHT INITIAL TENSIONING OF A MAGAZINE SPRING

10. When a fully or partly filled magazine is to be stored, the spring is given a slight initial tensioning that is just sufficient to hold the cartridges upright.

NOTE—A slight tensioning with the loading lever in the position shown in Figure 58 is sufficient. If the magazine is fully loaded or only partly filled, this slight initial tensioning is necessary to prevent a jam in the magazine.

11. If no initial tensioning is given the magazine spring, the cartridges are liable to fall out, become disarranged, or be tipped over when the magazine is lifted from the loading frame.

RELIEVING THE MAGAZINE SPRING TENSION

It may become necessary to relieve the spring tension on the magazine feed block to unload, to store, or to strip the magazine.

RELIEVING MAGAZINE SPRING TENSION

1. Place the magazine in the loading frame in the same manner as when loading. See Figure 48. Place loading lever in the spring tensioning axis as shown in Figure 63.

NOTE—The loading lever will not clear the magazine handle, so place it in such a position that it has room to move clockwise from one side of the handle to the other.

2. The tension of the spring causes pressure on the ratchet teeth of coupling sleeve shown in Figures 59, 60 and 61. Therefore, press counter-clockwise on the loading lever to relieve this pressure, and at the same time disengage the coupling sleeve with the other hand by pulling outward, Figure 60, and turning about one-eighth turn, so that the sleeve stays disengaged. See Figure 61.

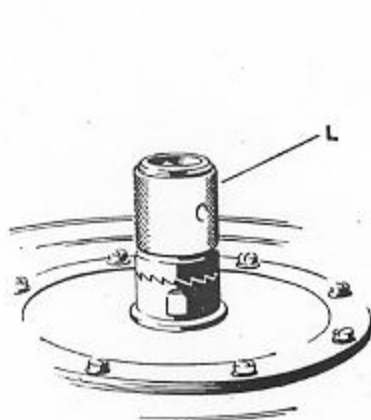

Figure 59

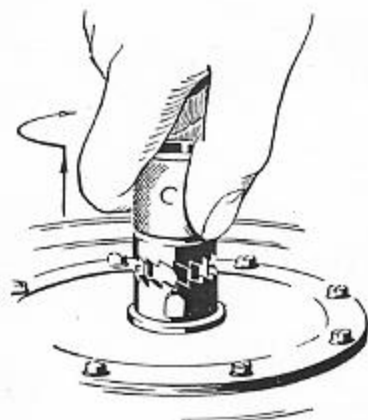

Figure 60
Coupling Sleeve Positions

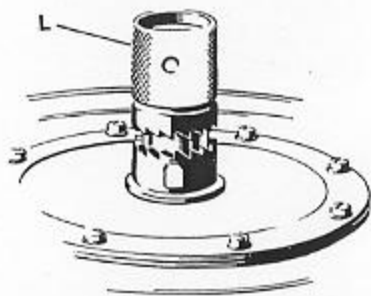

Figure 61

3. Allow the loading lever to move clockwise, as far as it can (until it contacts the magazine handle). Turn the coupling sleeve slightly and allow it to snap down and mesh the ratchet teeth. See Figure 59.

4. Press on the loading lever ratchet pawl and revolve the loading lever back to position from which it started in Step 1. Then release the pawl.

5. Repeat Step 3, until the spring tension is completely relieved and no pressure can be felt against the lever.

NOTE—If the cartridges are to be left in the magazine, the spring must be given a slight initial tension before taking the magazine out of the loading frame in order to prevent their falling out, or being tipped over, Figure 57.

MAGAZINE



Figure 62—Unloading a fully tensioned magazine

revolve it clockwise with one hand, so that a cartridge is constantly being pressed against the magazine mouthpiece. Use the other hand, and push out the cartridges as they appear at the mouthpiece.

NOTE—The loading lever must be made to revolve continuously as the cartridges are being removed, or the cartridges will upset and jam. IF THIS HAPPENS IT IS NECESSARY TO DISMANTLE THE MAGAZINE TO CLEAR THE JAM.

UNLOADING A FULLY TENSIONED AND PARTLY FILLED MAGAZINE

It is advisable to relieve the spring tension by using Steps 1, 2, 3, 4 and 5, Page 72, and then unload the cartridges as instructed above. See Figure 63.

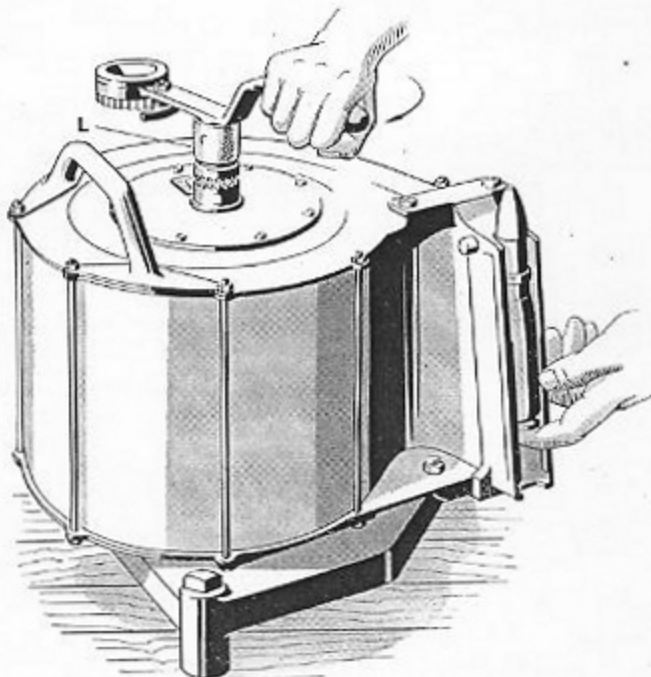

Figure 63—Unloading a partly tensioned magazine

STRIPPING THE MAGAZINE

STRIPPING THE MAGAZINE

NOTE—The magazine should be stripped by an artificer.

1. Place magazine in loading frame.
2. Empty the magazine of cartridges unless the stripping is being done to eliminate a jam, in which case it will be necessary to proceed with cartridges still in the magazine.
3. There are eight screws that hold the cover plate (I), Figure 64, on the magazine. Remove six of these, leaving any two that are directly opposite each other, in place.
4. Install the loading lever on the spring axis as shown in Figure 66, and relieve spring pressure as instructed on Page 72, Steps 2, 3, 4 and 5.

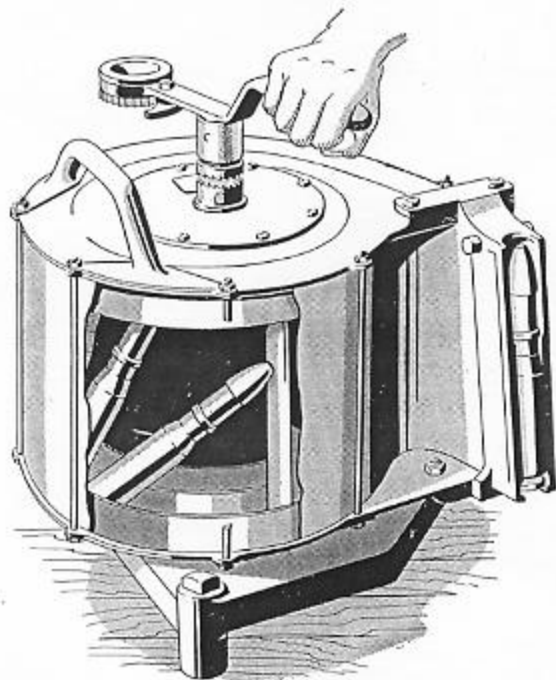

Figure 64—Magazine jammed requiring dismantling

The following are the references on Figure 65:

- | | |
|---|--|
| A—Magazine spiral guide—rear—inner (OE-1543) | N—Feed head (OE-1563) |
| B—Magazine spiral guide—rear—outer (OE-1542) | O—Cartridge feeder (OE-1567) |
| C—Magazine spiral guide—front—inner (OE-1540) | P—Stop bolt—long (OE-1576) |
| D—Magazine spiral guide—front—outer (OE-1539) | Q—Articulating bolt (OE-1564) |
| E—Spring (OE-1572) | R—Articulating bolt roller (OE-1565) |
| F—Main shaft (OE-1584) | S—Casing (OE-1544) |
| G—Spring axis (OE-1582) | T—Front plate (OE-1537) |
| H—Spring case (OE-1570) | U—Rear plate (OE-1538) |
| I—Cover plate (OE-1581) | V—Feeder arm (OE-1561) |
| J—Indicator block (OE-1583) | W—Stop bolt—short (OE-1577) |
| K—Feed block (OE-1549) | X—Lugs where spring fastens to spring axis |
| L—Coupling sleeve (OE-1529) | Y—Cartridge |
| M—Cartridge feeder link (OE-1579) | Z—Ratchet cross pin (OE-1587) |

STRIPPING THE MAGAZINE

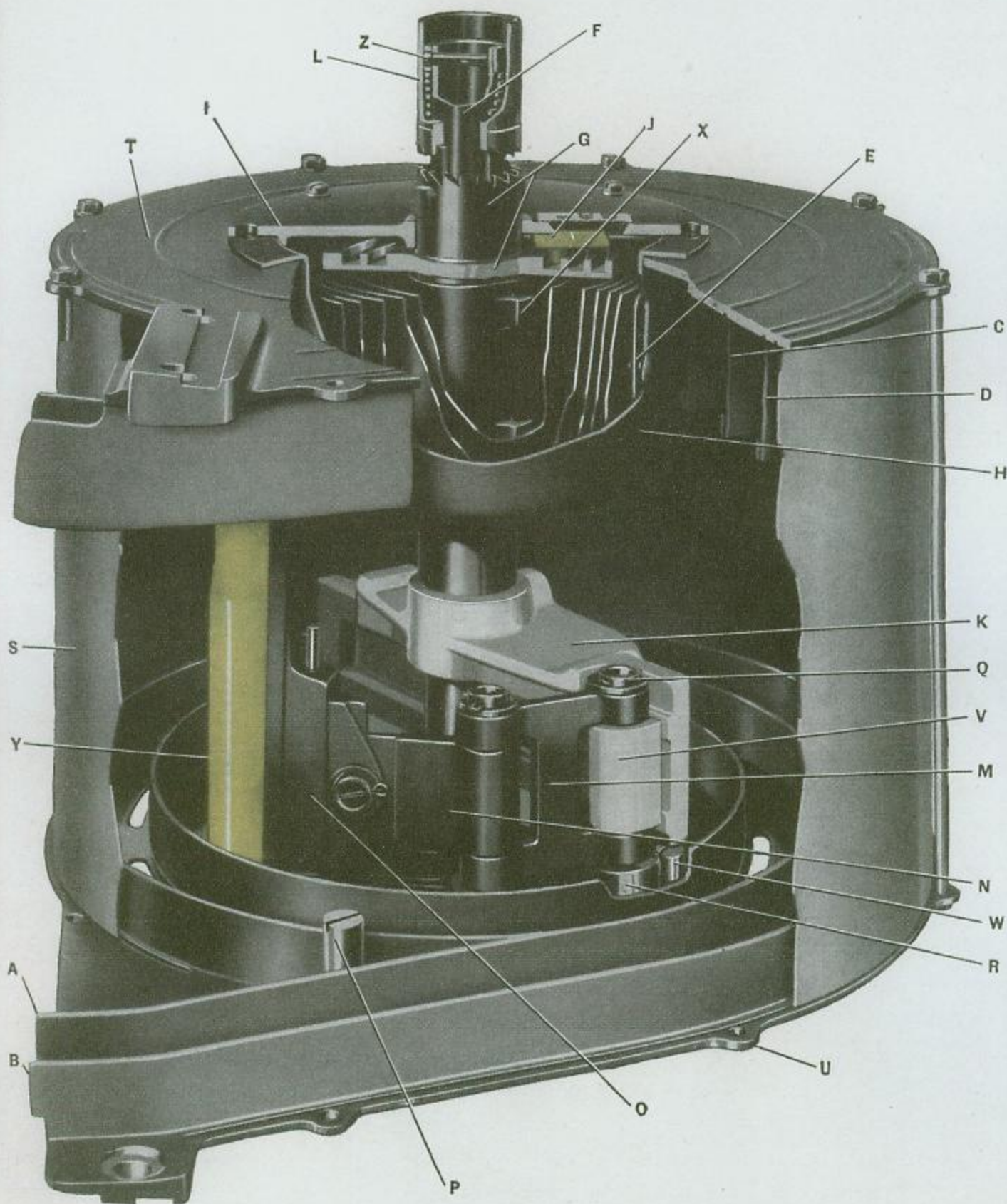

Figure 65—Magazine

STRIPPING THE MAGAZINE

5. With coupling sleeve disengaged, Figure 61, place the loading lever on the feed axis, Figure 66, and revolve it counter-clockwise, until the cartridge feeder (O), Figure 65, is at the inner end of its travel.
 6. Turn the coupling sleeve so that it snaps down and engages the ratchet teeth, Figure 59.
 7. Install the loading lever on the magazine spring axis as shown in Figure 67. Turn the loading lever counter-clockwise just far enough to take the slight remaining spring tension.
 8. Hold the loading lever in the position described in Step 7, and remove the two remaining screws from the cover plate (I), Figure 65. Keep the loading lever in the position given in Step 7, and loosen the cover plate (I) from the magazine with a screw driver or suitable tool, being very careful not to pry up the spring casing flange.
- NOTE—The loosening of the cover plate with a screw driver frees it from the spring casing, and now the remaining spring tension may be allowed to rotate the loading lever clockwise.**
9. All spring tension is now eased off and the loading lever can be unshipped.
 10. Rotate the spring housing assembly until one of the holes in the coupling sleeve is in line with the head of ratchet cross pin (Z), Figure 65.
 11. Lift spring case (H) containing spring (E) accompanied by the spring axis (G) until its flange clears the dowel screw in the front plate (T), and turn it until the letters "D" in the front plate (T) and cover plate (I) are in line. As the spring and case are supplied as an assembly under part number (299709) it is not necessary to remove the spring from the case. If either part is damaged, replace with the new assembly. Remove the spring axis (G) by twisting it in the spring to disengage lugs (X) from the holes in the spring.
 12. Remove the snap ring from the rear end of the main shaft (F), using pliers (OE-1608) in tool roll.
 13. Remove the complete main shaft (F), feed block (K), feeder link (M) and cartridge feeder (O) from the front.
 14. The feeder link (M), feed block (K), and cartridge feeder (O) can be separated by removing the bolt cotter pins and tapping out the two articulating bolts (Q), and feeder swivel bolt, using (OE-1613) punch in tool roll.
 15. The magazine casing (S) should not normally be stripped into its component parts.

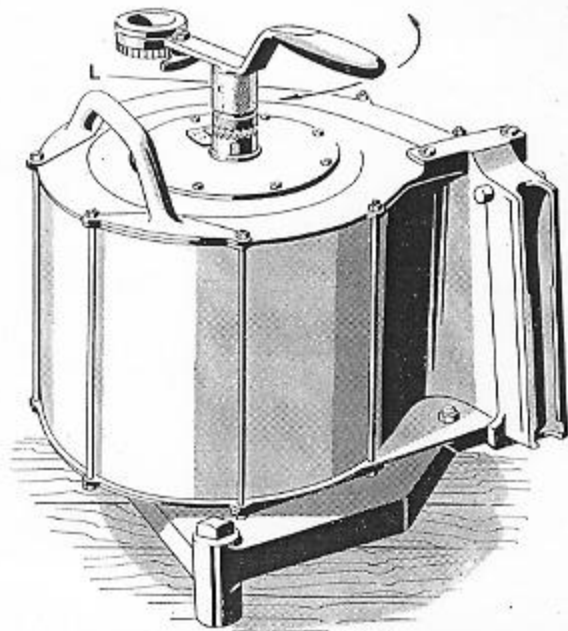

Figure 66—Magazine loading lever on main shaft (feed axis)

REASSEMBLING THE MAGAZINE

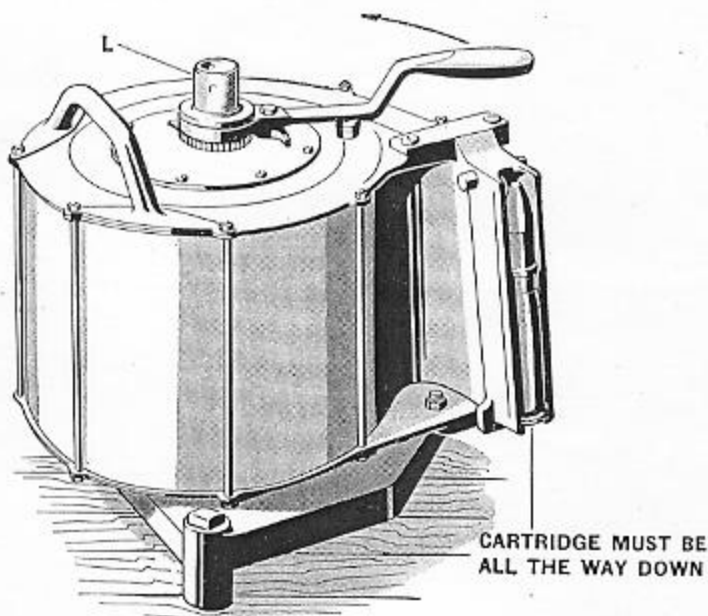

Figure 67—Loading lever on spring axis

REASSEMBLING

Thoroughly lubricate all parts. See Magazine Maintenance on Page 78.

1. Assemble the main shaft (F), feed block (K), feeder arm (V), feeder link (M), two articulating bolts (Q) with their rollers (R), feed head (N), bolt washers, bolt cotter pins and cartridge feeder (O).
2. Lubricate, see Page 78, and insert this feed group assembly into the magazine from the front. Engage the rollers (R) in the spiral guideway (A) and (B). Insert the rear end of the main shaft into its bearing in the rear plate.
3. Assemble the snap ring at the rear end of the main shaft. To check the action, turn the feed system so that the cartridge feeder (O) is outward at the limit of its travel in the empty position.
4. Pack the spring and case assembly with grease (OS-1350). Insert spring axis (G) in spring (E) and engage lugs (X) in the two holes in the center turn of the spring. Insert this assembly into the magazine with the letters "D" in line. Rotate the spring case until the dowel hole marked "O" in its flange, engages the dowel screw in the front plate of the magazine.

NOTE—Examine the spring case holes that are counter-clockwise from the hole marked "O." In a few cases they may be marked "1," "2," "3," and up. If these markings are found, then turn the spring case (H) so that the hole with the highest number, instead of the hole marked "O," is engaged with the dowel screw on the front plate of the magazine.

5. Place the cover plate (I) on the magazine, and do **not** install any screws in it. Move the indicator block (J) with a knife blade, or any similar tool, so that it engages in the spiral groove on the spring axis (G), Figure 65.

NOTE—Up to this point it is permissible to have the cover plate (I) in any position; also the indicator block (J) can be engaged in the spiral groove of the spring axis (G) in any position.

REASSEMBLING THE MAGAZINE

6. Turn the cover plate (I) counter-clockwise until the indicator shows zero and the indicator block (J) can be felt coming up against the clock spring (E).
7. Assemble the coupling sleeve (L) with its spring, the retaining ring and the cross pin.
8. Slip the loading lever on the spring axis (G) as shown in Figure 67 and turn the loading lever counter-clockwise about seven-eighths of a revolution or until the letter "A," stamped on the cover, is in alignment with letter "A" stamped on the magazine casing.
9. Maintain this position by holding the loading lever, and install the eight cover screws.

CAUTION—The counter-clockwise rotation of the cover from the zero position in Step 6 to "A" alignment in Step 8, has to be done against the clockwise pull of the clock spring. Approximately seven-eighths' revolution of the cover by the loading lever, should bring the alignment marks "A" opposite each other. **BE VERY CAREFUL NOT TO TURN MORE THAN THIS AMOUNT. ALSO, DO NOT ALIGN MARKS "A" BY TURNING THE LOADING LEVER CLOCKWISE.**

CHANGING MAGAZINES

It is essential that the magazine loader be adept in changing magazines. The proper procedure is as follows:

- (a) Grasp the magazine front handle with the right hand and cock the magazine catch by pushing forward on the lever with the left hand.
- (b) With the right hand, tilt the magazine slightly with the forward end down, grasp the magazine rear handle with the left hand and remove the magazine from the gun.
- (c) Tilt the loaded magazine slightly with the forward end down and the forward guide lugs slipped **all the way forward** flush against the magazine receiving slot.
- (d) Next, the rear of the magazine is put smartly into place with a sharp downward motion.
- (e) Check to see that magazine is firmly locked in place by shaking with the handles. If locked there will be no motion of magazine.

MAGAZINE MAINTENANCE

CORRODED OR DRY MAGAZINE

If a magazine becomes dry or corroded internally, it must be disassembled, cleaned, and lubricated with grease (OS-1350). See instructions for disassembling and reassembling magazine, Page 74.

MAGAZINE CLOCK SPRING

The magazine clock spring was packed with grease, when the magazine was issued. However, this grease tends to squeeze out in service. Watch this spring for evidences of corrosion, and if corrosion is found, clean and repack with grease (OS-1350).

MAGAZINE INTERLOCK BOLT

The spring that is behind the magazine interlock bolt may become corroded, or may operate slowly, due to the use of too thick an oil, or because the oil thickens in cold weather. This magazine interlock bolt is the part on magazine cartridge feeder that causes the gun to be held in a cocked position when the magazine has fed its last round to the gun. See Page 48 for detail description. Therefore, any corrosion or slow operation

MAGAZINE MAINTENANCE

due to thick or thickened oil, will cause the gun to fail to remain in a cocked position after firing the last round of each magazine.

Use grease (OS-1350), and apply **sparingly** and often.

GENERAL LUBRICATION OF MAGAZINE

All moving parts should be lightly coated with grease (OS-1350). A light coat of the same grease should be applied to the spiral guideways in the magazine.

NOTES

SIGHT

Chapter 7

DESCRIPTION OF SIGHTS

There are five types of sights in use: 20 mm. Sights Mark 2, Mark 4, Mark 4 Mod. 1, and Mark 5 and Gun Sight Mark 14 Mod. 2.

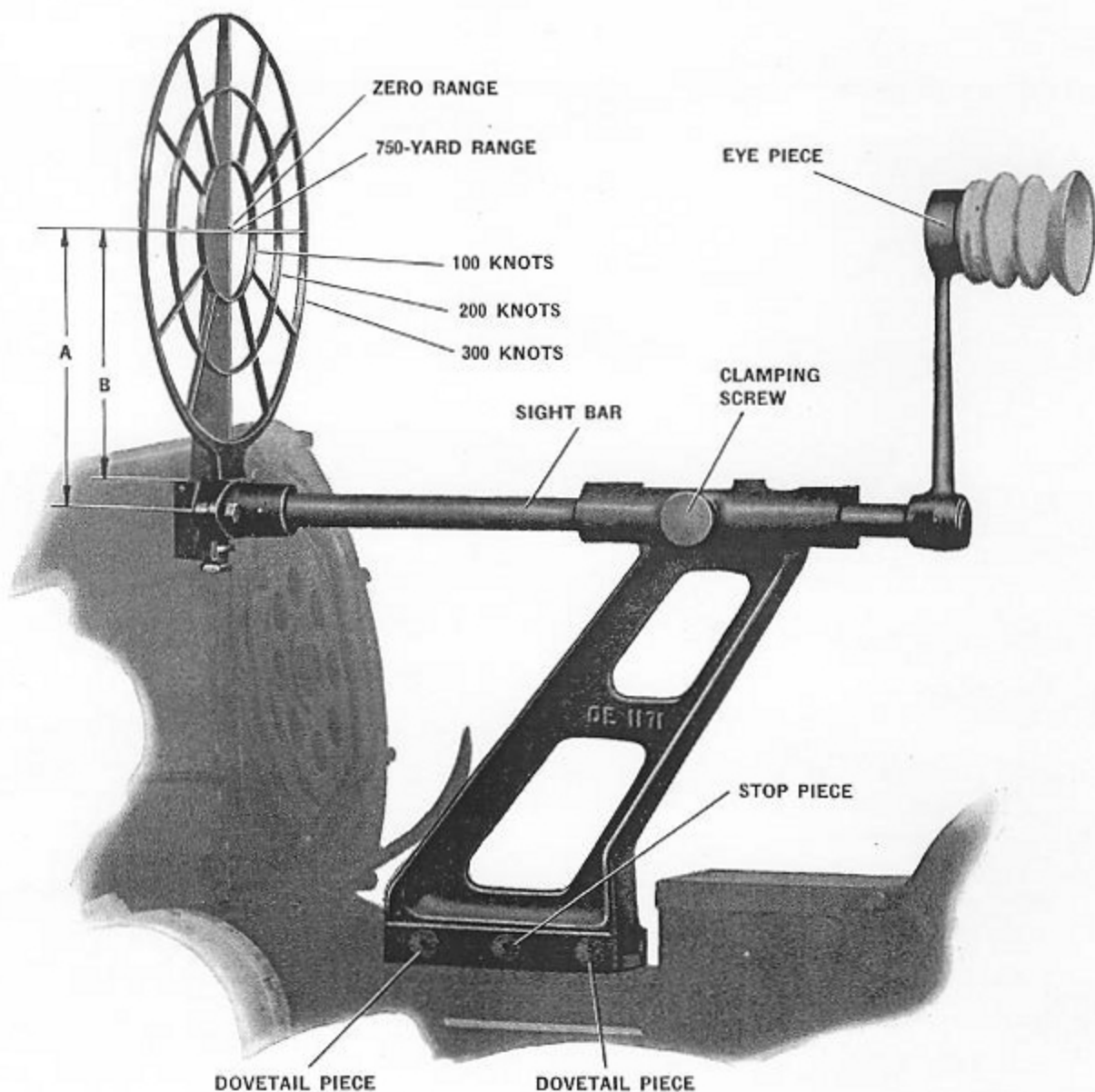

Figure 68—Sight Arrangement—Mark 4

Mark 4 and Mark 4 Mod. 1 sights can be easily distinguished by their name plates. Mark 4 sight is illustrated in Figure 68. The bracket on Mark 4 Mod. 1 is one inch lower than the one on Mark 4, and has less backward slope. This brings the line of sight one inch closer to the gun. Changes in the sight bar maintain the eye piece in the same fore and aft location.

SIGHT

The Mark 2 sight is identical in appearance to Mark 4, except that it has an adjustable back sight.

Mark 5 sight, illustrated in Figure 69, uses a single adjustment which compensates for both range and elevation and has a simple elevation indicator.

Operating instructions and boresighting information for Gun Sight Mark 14 Mod. 2 are covered in Ordnance Data 4429 which is issued with the gun sight.

USE OF SIGHTS MARK 2, MARK 4, AND MARK 4 MOD. 1

The Mark 2 sight has an adjustable backsight having two positions: One for 750 yards range (marked "Normal"), and one for parallel bore sighting (marked "Zero Line Up").

Mark 4 and Mark 4 Mod. 1 sights are calculated for a horizontal range of 750 yards. The backsights are fixed. The foresight horizontal bar is used for 750 yards range and there is a white mark on the vertical center bar to indicate parallelism.

The line of sight from the backsight (set to Normal in case of Mark 2) to the center of the foresight is 24.5 minutes below a line parallel to the axis of the bore of the gun. This gives 24.5 minutes elevation of the bore above the line of sight, which corresponds to the elevation required for a horizontal range of 750 yards.

The 100, 200, and 300-knot rings indicate the approximate amounts of lead required, at average ranges, against targets whose speed components across the sight are 100, 200, and 300 knots, respectively.

SHIPPING AND UNSHIPPING THE SIGHT—MARK 4 AND MARK 4 MOD. 1

To ship the sight assembly on the gun, see that the three clamping screws (OE-1192) on the right hand side, see Figure 69, are loosened and that the two dovetail pieces (OE-1190), see Figure 68, and stop piece (OE-1191) are backed out of the sight bracket far enough to permit the sight to be set down over the vee ways on the breech casing. Set the sight bracket down over the ways on the breech casing. This can be done only when the rear of the bracket is back close to the trigger housing. Slide the sight forward until the rear edge of the sight bracket is flush with the back edge of the sight mounting ways on the breech casing. Turn the center clamping screw until the stop piece engages in the notch in the mounting ways. When this is engaged the sight bracket cannot be moved longitudinally. Do not tighten fully. Next tighten the front and rear clamping screws with spanner (OE-1189) and then tighten the center clamping screw firmly.

To unship the sight assembly, loosen the three clamping screws (OE-1192), see Figure 69, using spanner (OE-1189). The center screw must be backed out five or six turns and then pushed toward the left side until the stop piece, see Figure 68, is disengaged from the notch in the breech casing. Then slide the sight assembly back toward the trigger cover and lift it off the gun.

PREPARING SIGHT FOR STOWING—MARK 4 AND MARK 4 MOD. 1

When stowed in the sight box, the foresight is rotated 150 degrees to the left from the vertical, or firing position. This can only be done after unshipping the sight from the gun.

On Mark 2 and Mark 4, loosen the sight bar clamping screw, Figure 68, and back it out until the sight bar can be moved forward. Slide the sight bar forward through the bracket as far as it will go. Then rotate the foresight 150 degrees to the left. In this position the sight bar clamping screw will engage another hole in the sight bar. The clamping screw should be tightened securely.

On the Mark 4 Mod. 1 sight, loosen and back out the sight bar clamping screw, Figure 68. The foresight can then be rotated 150 degrees to the left and the sight bar clamping screw tightened into a hole in the sight bar to secure the assembly in this position.

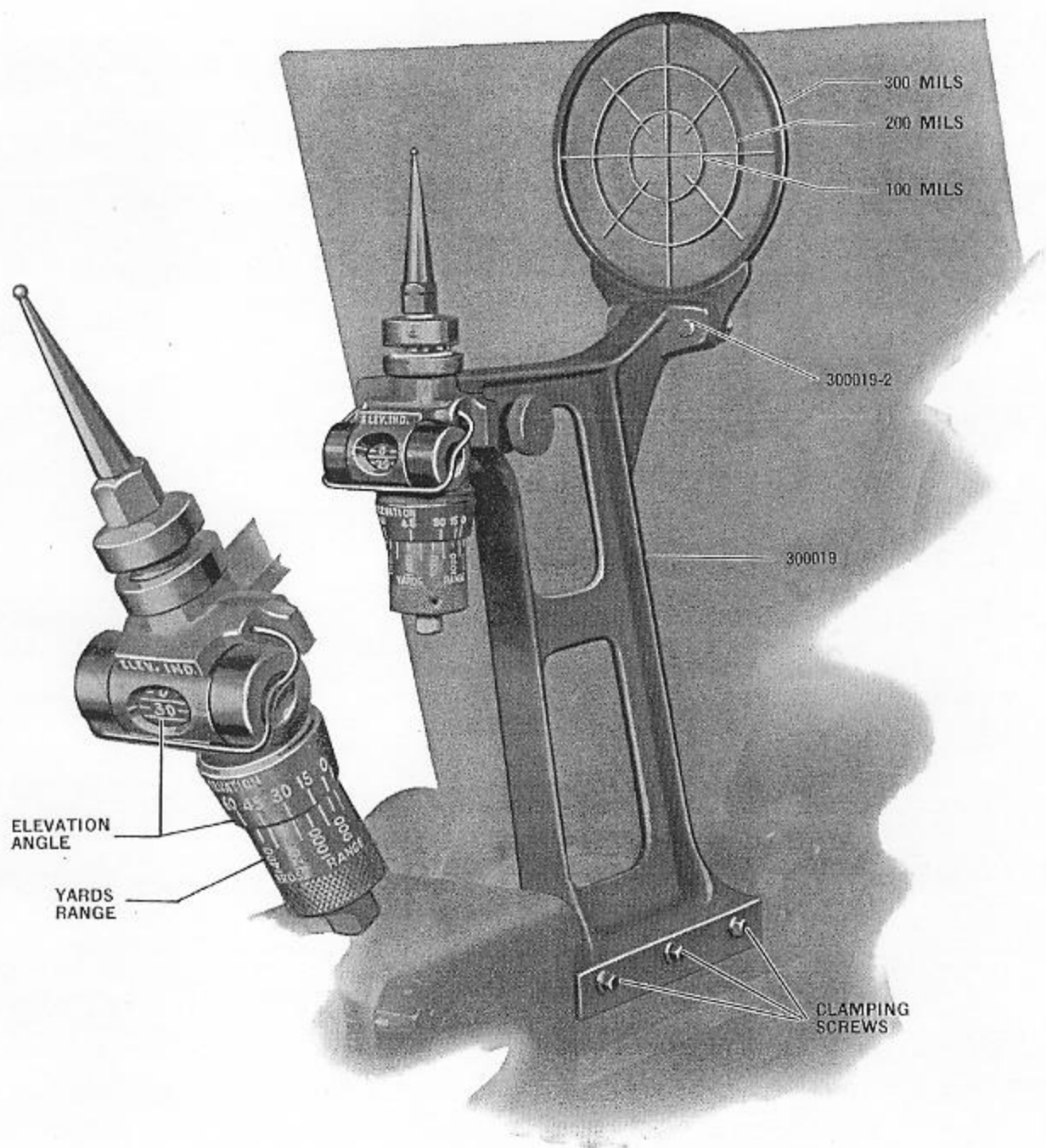

Figure 69—Sight Arrangement—Mark 5

SIGHT

CAUTION—When installing a sight on the gun, care should be taken that the sight bar clamping screw is properly engaged and tightened in the aligning hole in the sight bar. This is necessary to properly align the sight.

REPLACEMENT OF FORESIGHT ASSEMBLY—MARK 2, MARK 4, AND MARK 4 MOD. 1 SIGHTS

Should it be necessary to replace a foresight assembly, the gun must be boresighted and the foresight adjusted to the proper position as described on page 88.

MARK 5 SIGHT—DESCRIPTION

Sight bracket assembly (300019), Figure 69, is designed to permit the installation of this sight on both Mark 2 and Mark 4 guns.

Foresight assembly (300019-1) is attached to the front of the bracket with two tapered shank screws (300019-2). The foresight rings set at distances from the center of the foresight equal to 100 and 200 mils (U. S. N.). The inside of the supporting ring is 300 mils (U. S. N.) from the center of the sight.

Rear sight support assembly (300020), Figure 70, is accurately positioned by its spline in a mating recess in the sight bracket. It is adjustable horizontally by means of adjusting screw (300023-4) and is locked in position by screw (300023-5). The lower extremity of the rear sight support (300020), Figure 70, carries an elevation scale graduated in degrees.

Elevation indicator is mounted on rear sight support assembly (300020). This is read directly through a small opening located conveniently for the gunner when in firing position. The elevation readings are taken from drum assembly (300022) which contains two small weights (300022-3) and rotates freely on drum shaft (300023-2). The ends of the shaft operate in two bearing caps (300023-3) which are held in place by retainer (300023-1).

Rear sight collar assembly (300021), Figure 70, is used only for setting the sight at original assembly. Its adjustment should never be disturbed except when rear sight pin (300021-3) is removed for some reason or to allow for adjustments when bore sighting when the guns are in service. When replacing the pin the procedure under "Servicing", page 87, should be carefully followed. Also see "Bore Sighting" on page 88.

The rear sight pin assembly consists of pin (300021-3), range adjustment cylinder (300022-1), and set screw (300021-4). The cylinder, graduated in yards range, is firmly fixed to the pin by the set screw when the sight is originally adjusted and this relative positioning should not be disturbed.

Rear sight pin tip (300021-6) screws onto the end of sight pin (300021-3). A taper on the end of the sight pin fits in a corresponding seat at the lower end of the pin tip.

Friction spring (300022-2), Figure 70, is placed outside of range adjusting cylinder (300022-1) for the purpose of maintaining the setting of the cylinder.

OPERATION—MARK 5 SIGHT

It is only necessary for the gunner to choose his elevation and range and set the range adjusting cylinder. Elevate the gun to the angle at which firing is expected to occur. Observe elevation indicator reading. Estimate range and turn the range adjusting cylinder until the estimated range figure appears opposite the observed elevation figure.

The insert in Figure 69 shows the proper adjustment for 1100 yards range and 30° elevation.

SIGHT

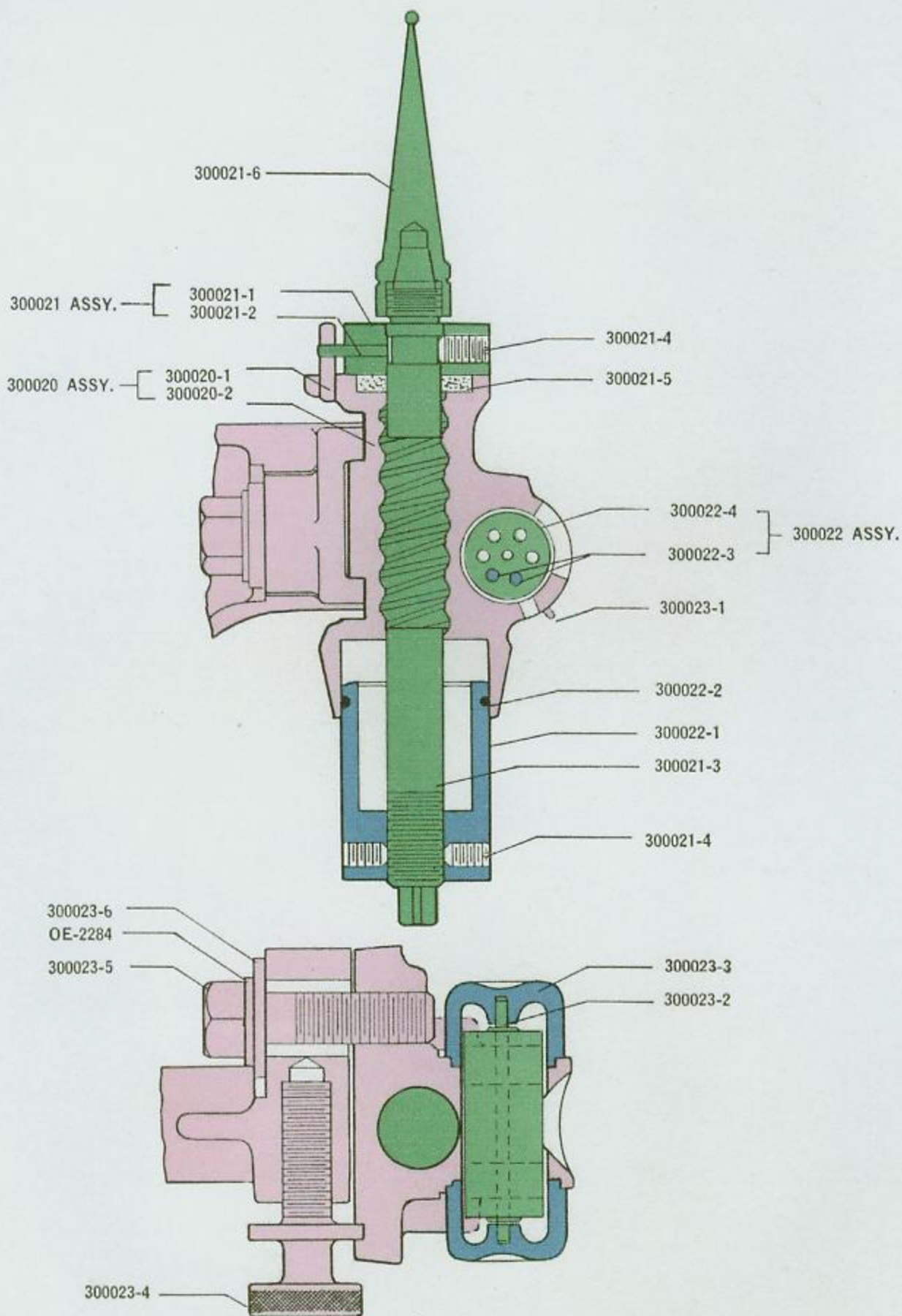
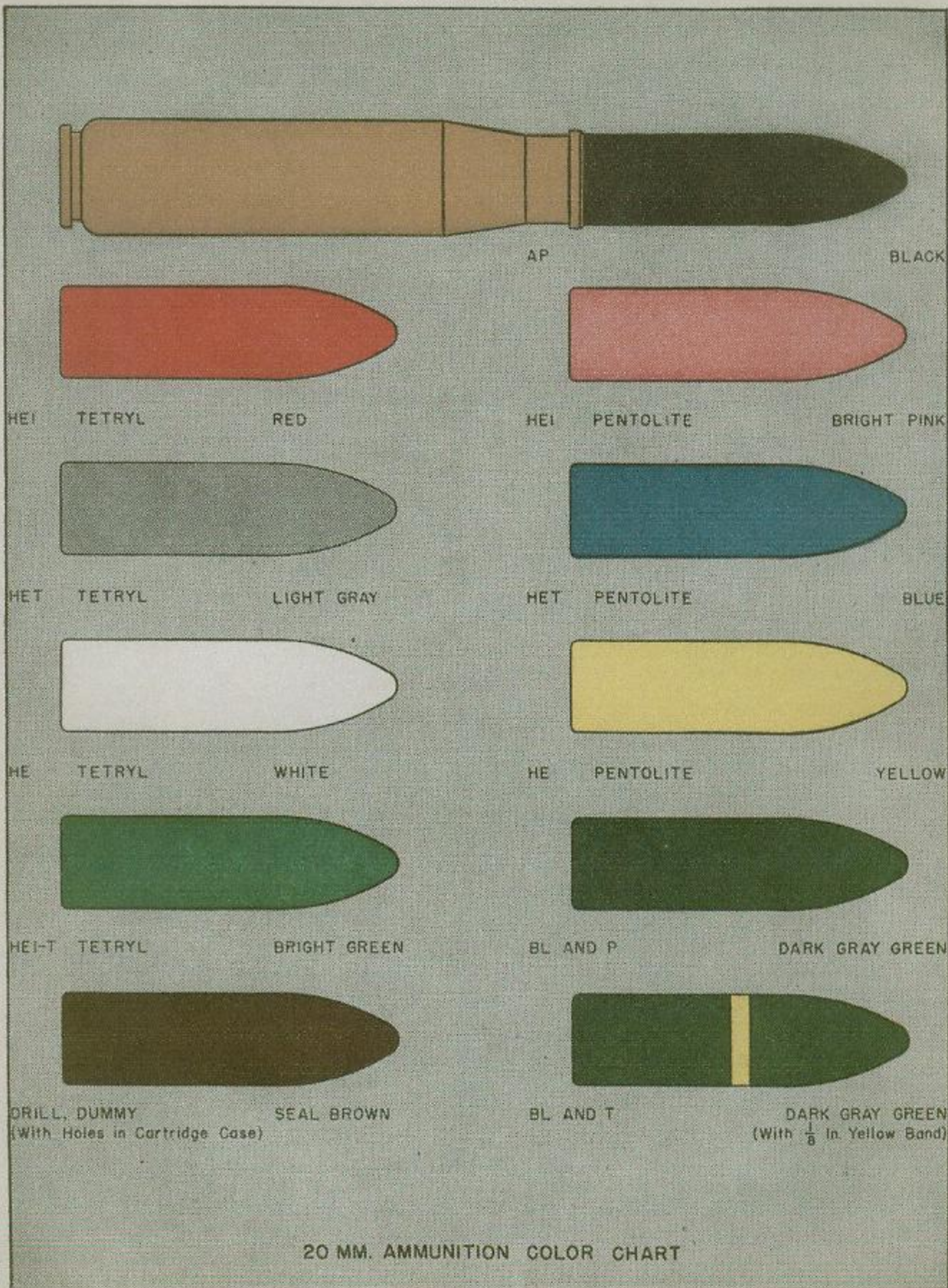

Figure 70—Mark 5 sight sectional view

AMMUNITION



20 MM. AMMUNITION COLOR CHART

SERVICING—MARK 5 SIGHT

Included with each sight in the sight box is one spare foresight assembly, three spare rear sight pin tips, and a $\frac{1}{4}$ " square socket with hinge handle.

Foresight—To change remove the two cap screws (300019-2), Figure 69, and take off the foresight. Place new foresight in position with large end of tapered holes and rivet head facing forward and reassemble the two screws. The taper on the screws matches with the tapered recesses in the foresight and, therefore, the error introduced by changeover is negligible.

Rear Sight Pin Tip—Rotate range adjustment cylinder (300022-1), Figure 70, until pin (300021-2) in initial adjustment collar (300021) is about one half turn away from the stationary vertical stop pin (300020-1) in the top of the rear sight support assembly (300020) (this procedure will prevent possible damage to stop pin by wrench slipping, etc.). Hold head on lower end of sight pin (300021-3) stationary with the $\frac{1}{4}$ " socket and hinge handle provided, and unscrew the tip (300021-6) from the pin, using an adjustable or $\frac{1}{2}$ " end wrench.

Install the new tip by reversing the foregoing operations, taking every precaution that the new pin tip is pulled down tight against the tapered seat. Setting of the rear sight collar assembly (300021) should not be disturbed during this operation.

Rear Sight Pin and Range Adjusting Cylinder Assembly—If for some reason it should become necessary to remove this, proceed as follows: Remove rear sight pin tip from sight pin according to foregoing instructions. Strip rear sight pin initial adjustment collar assembly (300021) by loosening set screw (300021-4). Remove sight pin (300021-3) and range adjustment cylinder (300022-1) as an assembly by screwing the pin downward. **Neither loosen nor remove the range adjustment cylinder from the pin.**

To reinstall these parts thread the rear sight pin assembly upward into its recess until the upper end of sight pin (300021-3) starts to project through sight support (300020-2). Reinstall felt seal (300021-5) in recess. Place rear sight collar assembly (300021) over upper end of sight pin and screw pin assembly upward until shoulder on sight pin (300021-3) is flush with top of collar assembly (300021). It will now be found that the 600 yard mark on range adjusting cylinder (300022-1) will register close to the 75 degree mark on the elevation scale. Set the 600 yard range mark exactly on the 75 degree elevation mark and hold in this location until rear sight collar assembly (300021) is turned clockwise (as viewed from above) against stop pin (300020-1). Then lock the collar to the sight pin with set screw (300021-4).

ALTERNATE REAR SIGHT PIN TIPS—MARK 5 SIGHT

As rounds fired on a barrel increase, bore and chamber wear occur to a degree definitely lowering the muzzle velocity of the projectile. Muzzle velocity and range of projectile decrease in like proportion, and therefore, some means of compensation for decrease in range with barrel wear must be provided to maintain sight accuracy with lowered projectile flight. To provide this type of compensation for the Mark 5 Sight, pin tips of different heights are furnished for first third, second third, and last third of normal barrel life. These pins are identified by grooves on hexagonal section as follows: First third has one groove (300021-6), second third has two grooves (300021-7), and last third has three grooves (300021-8). At the interval of barrel life corresponding to the noted classifications, pin tips should be changed accordingly to maintain sight accuracy with a changed trajectory of projectile. See "Life of the Gun Barrel," Page 111.

BORE SIGHTING INSTRUCTIONS

GENERAL

1. The bore sight is used to establish a line of sight coincident with the axis of the bore of 20 mm. A.A. guns. The line of sight, thus established, is used to check the line of sight of a front area type of open sight or of the Gun Sight Mark 14 Mod. 2, whichever is used. A bore clear mirror, an empty 20 mm. cartridge case modified as described hereinafter, and a set of crosslines at the muzzle comprise the bore sight.

2. **Modification of cartridge case**—A $\frac{3}{32}$ -inch diameter hole, centered with respect to the case periphery, is drilled through the primer end of an empty 20 mm. cartridge case. A suitable means may be provided for removing the cartridge case from the bore. The case, thus modified, is used to position the observer's eye relative to the axis of the barrel, thus reducing parallax and establishing a line of sight more nearly coincident with the axis of the gun barrel.

3. **Crosslines at muzzle**—In addition to the mirror and modified cartridge case, it may be found convenient to improvise a set of crosslines attached at the muzzle to assist in lining up the line of sight on the target. These may be made by lashing two wires to the muzzle bell. The wires should be perpendicular to each other and have their intersection on the axis of the gun bore. A second method is to solder the two wires to a cylindrical shell of the proper size to fit over the muzzle bell. Here again the wires should be perpendicular to each other and have their intersection at the center of the bore.

NOTE—Since an error of $\frac{1}{16}$ -inch in positioning the intersection of the crosslines on the axis of the bore will produce only about one mil error in the line of sight, the positioning may be done by eye.

PROCEDURE

4. The procedure used in bore sighting a 20 mm. gun equipped with an open ring sight is as follows:

- (a) Prepare a target or batten by ruling vertical and horizontal lines whose intersections represent the position of the line of sight with respect to the axis of the gun barrel. See Figure 71. As a starting point for the layout, the point where the axis of the bore intersects the target should be chosen. The other lines may then be laid out from this point.

NOTE—The lines should be laid out as accurately as possible since the bore sighting distances involved will be short, and mistakes in the layout will cause appreciable errors in the bore sighting results.

- (b) Secure the gun at 5 degrees elevation by means of the cradle locking bolt. Place the target in position in front of the gun and as far distant as the ship's structure will permit, but near enough to make the target lines clearly visible. The target should be perpendicular to the gun axis with the gun at 5 degrees elevation.
- (c) Seat the modified cartridge case firmly in the gun barrel, mount the bore clear mirror in position on the breech casing, and secure the cross wires at the muzzle. The line of sight is now coincident with the axis of the gun barrel.
- (d) Adjust this line of sight by shifting the batten, so that the muzzle cross wires center on their corresponding horizontal and vertical lines on the target. Check the batten after this adjustment to see that it still is perpendicular to the gun axis.
- (e) Now check the line of sight through the rear sight and foresight to see that it lines up on the intersection of the vertical and horizontal lines which represent the position of this line of sight with respect to the bore.

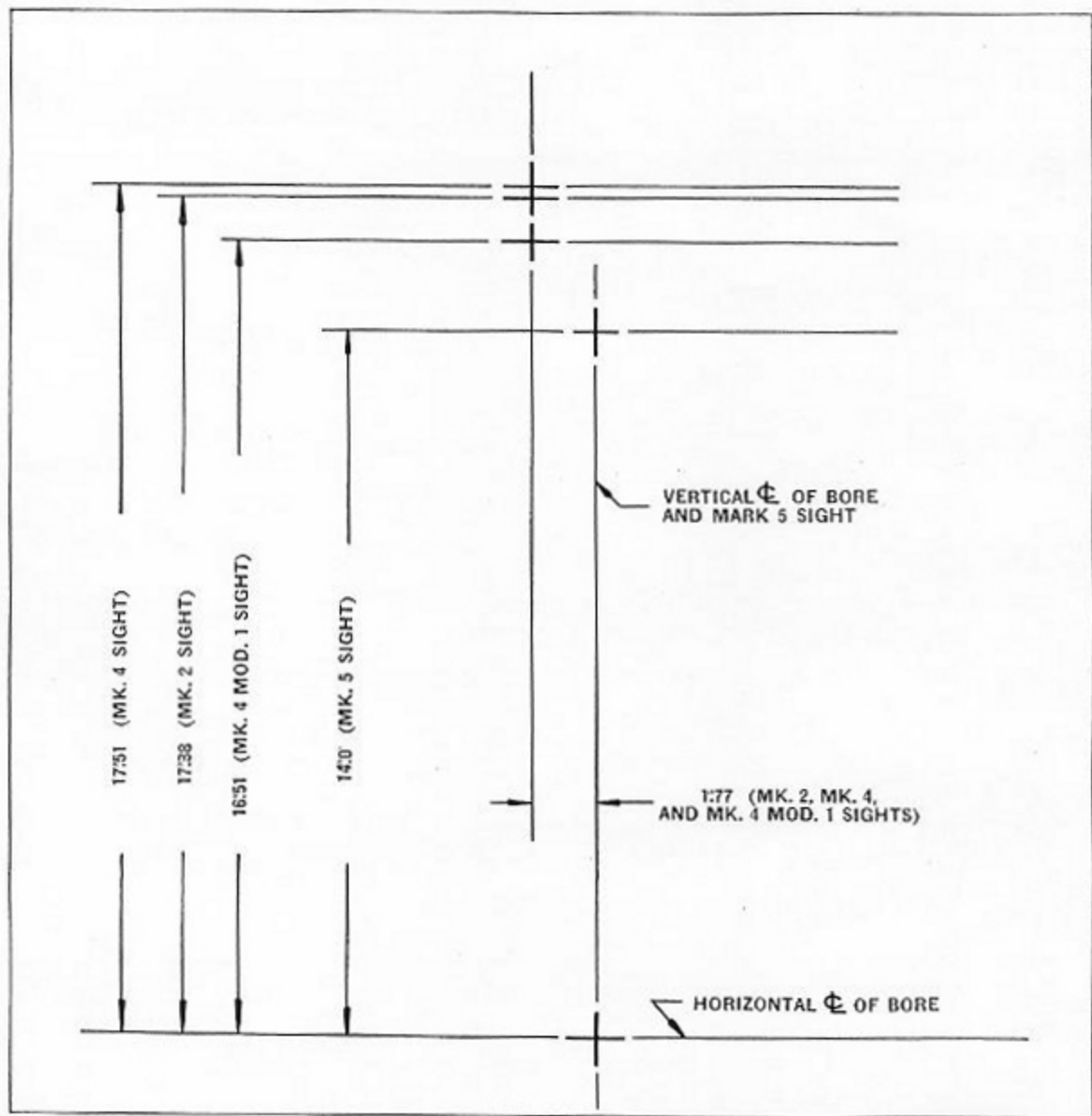

Figure 71—Bore Sight Target

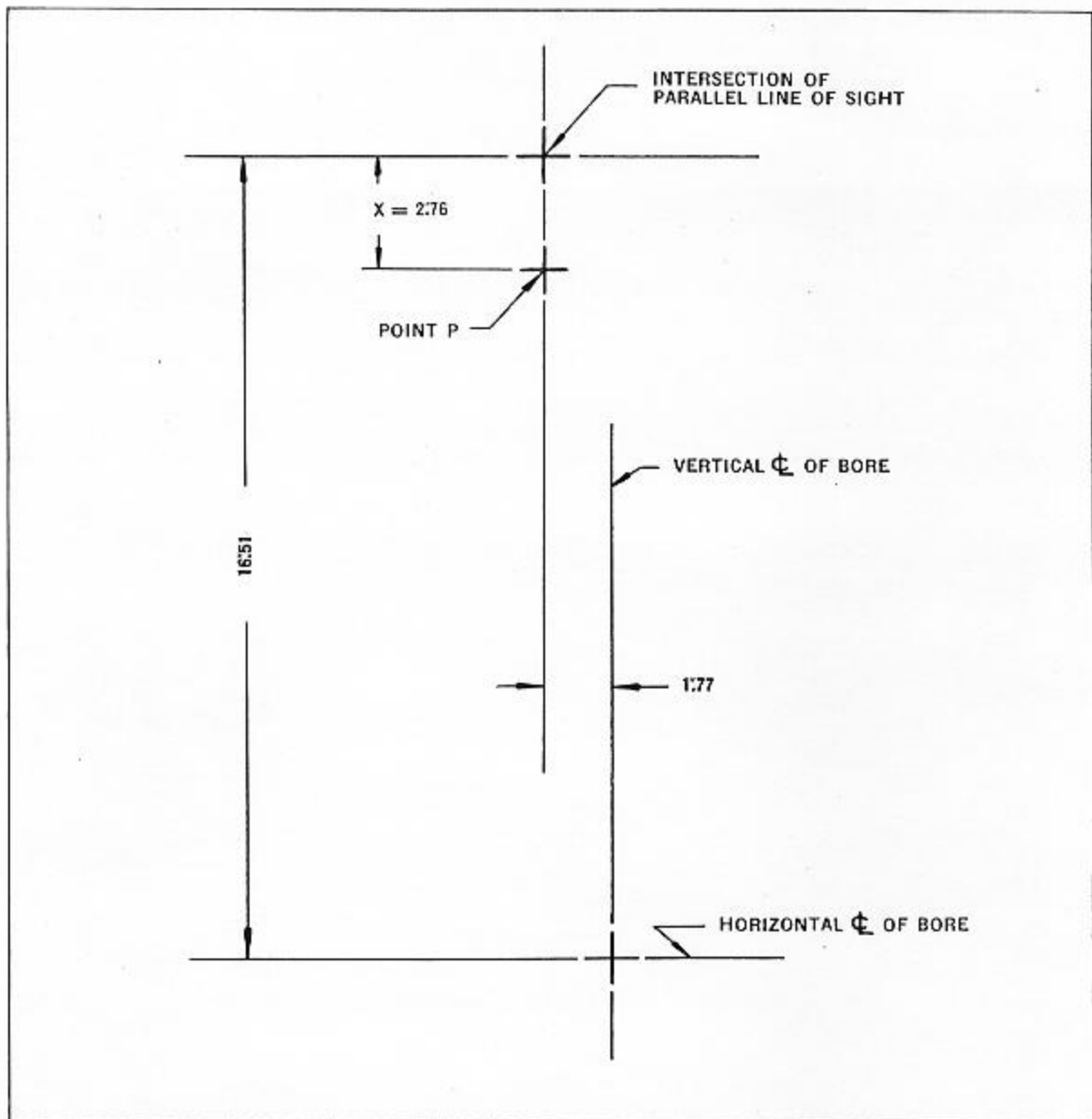

Figure 72—Bore Sight Target for 20 mm. Sight Mark 4 Mod. 1
 Locating point "P" for adjusting line of sight to intersect trajectory of
 projectile at 1000 yds. range and 45° elevation (See example on Page 91.)

SIGHT

NOTE—To do this accurately, it will be necessary to position the eye about 24 inches back of the rear sight. Further, be sure to use the parallel bore sighting mark (small notch above the horizontal bar) on the foresight of 20 mm. Sights Marks 4, and 4 Mod. 1, and to have the rear sight of 20 mm. Sight Mark 2 in the "zero line up" position. For Sights Mark 5, see paragraph (6).

(f) If errors in either elevation or deflection are found by the above procedure, adjustments made as described hereinafter will be necessary.

5. The following methods of adjustment for the errors found by bore sighting are applicable to the foresight of 20 mm. Sights Mark 2, Mark 4, and Mark 4 Mod. 1.

- (a) If the line of sight does not intersect its vertical line on the target, a deflection error is apparent. It is corrected by loosening the two clamping bolts near the bottom of the ring foresight and moving the sight horizontally until the line of sight intersects the vertical line.
- (b) If the line of sight is in error in a vertical direction, an elevation adjustment is made by loosening the same two clamping bolts as in (a) above, and then moving the foresight up or down by means of the adjusting collar at the bottom of the clamp. (On the Mark 2 Sight there are two collars to be adjusted).

The procedure outlined above will adjust the line of sight through the center of the rear sight and the center of the foresight to intersect the trajectory of the projectile at a horizontal range of approximately 750 yards. (This is true in the case of Sight Mark 2 when the adjustable rear sight is set to the "Normal" position). To set the line of sight so that it intersects the trajectory of the projectile at **any desired range and elevation**, the following formula can be used for locating a corresponding point, (P), Figure 72, on the bore sight target where the line of sight must intersect.

$$X = D \left[(.00349) A + \frac{5.667}{R} \right]$$

where D = distance, in feet, from rear sight to batten.

R = range, in yards.

A = super-elevation of sight, in minutes, (from 20 mm. A.A. Range Tables).

X = vertical distance, in inches, on the batten from intersection of parallel line of sight to point (P).

When the distance (X) has been determined from the above formula, mark point (P) on the batten as shown in Figure 72 (for the case of a Mark 4 Mod. 1 Sight). With the target set up and adjusted as outlined in paragraphs (4b), (4c), and (4d), loosen the clamping bolts, move the foresight up or down until the line of sight through the center of the rear sight and the center of the foresight intersects the mark point (P) on the batten and then tighten the clamping bolts. Note that in this case the center of the foresight is used and not the parallel bore sighting notch above the horizontal bar on the foresight of 20 mm. Sights Marks 4 and 4 Mod. 1. On the 20 mm. Sight Mark 2, the rear sight must be in the "Normal" position. The following example will serve to illustrate the method of setting the line of sight to intersect the trajectory of the projectile at any desired range and elevation.

Example:—It is desired to adjust the line of sight on a 20 mm. A.A. Gun equipped with a Mark 4 Mod. 1 Sight so that the line of sight will intersect the trajectory of the projectile at a range of 1000 yards and an elevation of 45 degrees. The gun mount installation permits the location of the batten at a distance of 25 feet forward of the rear sight.

- (a) In the formula

$$X = D \left[(.00349) A + \frac{5.667}{R} \right]$$

$$D = 25 \text{ feet}$$

$$R = 1000 \text{ yards}$$

$$A = 30 \text{ minutes (from 20 mm. A.A. Range Tables).}$$

Substituting these values in the formula,

$$X = (25) \left[(.00349) (30) + \frac{5.667}{1000} \right]$$

$$X = 2''.76$$

- (b) Lay off on the batten the distance $X = 2''.76$ vertically downward from the mark indicating the point where the parallel line of sight intersects the batten. Mark the point (P) as indicated in Figure 72.
- (c) Set up the batten at a distance of 25 feet forward of the rear sight and adjust as outlined in paragraphs (4b), (4c) and (4d). Loosen the clamping bolts on the foresight and move the foresight vertically until the line of sight through the center of the rear sight and the center of the foresight intersects the batten at point (P). Tighten the clamping bolts. The line of sight is now adjusted to intersect the trajectory of the projectile at 1000 yards range and 45 degrees elevation.

6. On 20 mm. Sights Mark 5, if the line of sight does not intersect its vertical line on the batten, it may be corrected by loosening the rear sight support locking screw (300023-5) and moving the rear sight pin horizontally by means of the adjusting screw (300023-4) until the line of sight intersects the vertical line. To check the line of sight in the vertical direction, set the 1000 yard range mark on the range adjustment cylinder to line up the 75 degree mark on the elevation scale. If the line of sight through the center of the ball on the rear sight pin tip and the center of the foresight does not line up with the horizontal line on the batten, the following adjustments should be made:

- (a) Loosen the initial adjustment collar (300021-1) by means of the set screw (300021-4). Loosen the range adjustment cylinder (300022-1) from the rear sight pin by means of the set screws (300021-4).
- (b) Turn the square head on the rear sight pin until the line of sight intersects the horizontal line on the batten.
- (c) Hold the rear sight pin stationary in the above adjusted position and rotate the range adjustment cylinder until the 1000 yard mark is exactly in line with the 75 degree mark on the elevation scale.
- (d) Tighten the range adjustment cylinder to the rear sight pin by means of the set screws.
- (e) Align the 600 yard mark on the range adjustment cylinder with the 60 degree mark on the elevation scale and rotate the initial adjustment collar clockwise (as viewed from above) to the stop pin (300020-1). Lock the collar in this position by means of the set screw (300021-4) with the base of the collar in contact with the sight support.

It should be noted that the foregoing adjustment does not provide an exact super-elevation setting for 1000 yards range and 75° elevation. In order to simplify the sight, certain approximations have been necessary and when the bore sighting adjustments are made as outlined above, the error throughout the range and elevation scales is reduced to a minimum.

The single groove rear sight pin tip (300021-6) should always be used when bore sighting. The pin tips bearing two grooves (300021-7) and three grooves (300021-8) are provided to compensate for bore erosion during the life of the gun, but should never be used for bore sighting purposes.

NOTES

NOTES

SHOULDER REST

Chapter 8

MARK 2 AND MARK 4 SHOULDER REST ASSEMBLY (OE-1500)

On this type assembly the shoulder rest is separate from the hand grips. The shoulder rest, however, is turned onto the rear face of the hand grips and locked in place by a catch attached to the bottom of the shoulder piece frame.

The shoulder rest pads, which are of rubber with a steel reinforcement band, are rotatable to conform to the gunner's shoulders.

A telescoping type shoulder frame holder, adjusted by a knurled knob on the right end of the threaded spindle permits lateral adjustment of the shoulder rest pads to meet the gunner's shoulder width.

The shoulder rest strap is fitted with a buckle at the center to permit it to be adjusted to the gunner's requirements.

SHOULDER REST ASSEMBLIES MARK 5 AND MARK 5 MOD. 1

Two types of shoulder rests with integral hand grips are used. Mark 5 shoulder rest has rubber shoulder pads as shown in Figure 73. Mark 5 Mod. 1 shoulder rest is identical to Mark 5, except that it has fabric straps instead of rubber pads. This latter type is being discontinued in production.

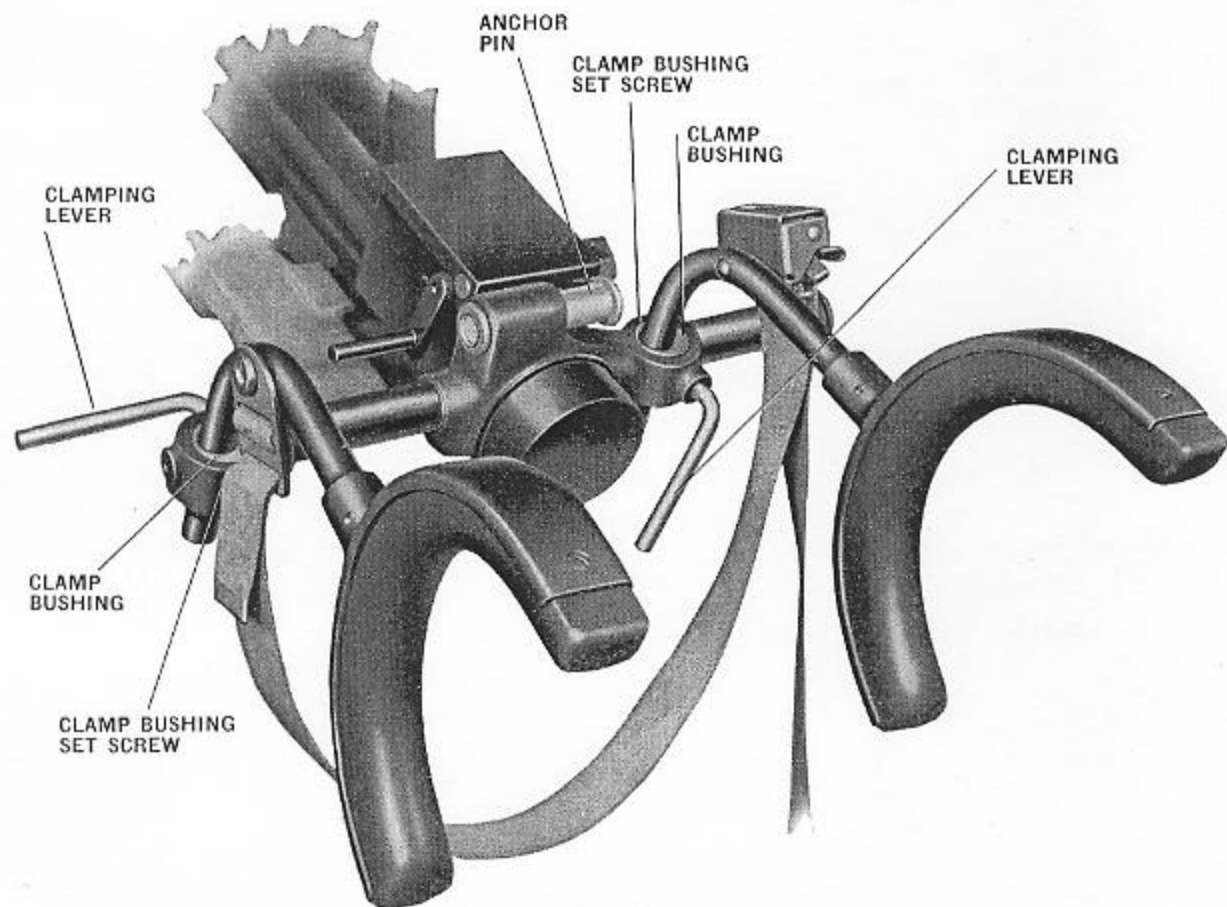

Figure 73—Mark 5 shoulder rest

SHOULDER REST

The integral hand grips and shoulder rest design provides right and left rest pads and support assemblies which have several adjustments to permit the gunner to fit himself into the most advantageous position for his particular physical proportions. The adjustments are quickly and easily made as noted below.

NOTE—Due to interference when Mark 14 Mod. 2 gun sight is installed, revisions are being made in the Mark 5 shoulder rest whereby the strap anchor plate (OE-1719) is being assembled on the right shoulder piece support instead of on the left support. The position of the strap is then reversed so that the buckle is attached to the rivet head on the left side to provide the clearance desired for the gun sight support. Where desired, this revision can be made on board ship by removing rivets (OE-1288) and reassembling the anchor plate on the right support.

Due to cancellation of the Mark 4 block and tackle type cocking tool, further changes are being effected in the Mark 5 shoulder rest which omit anchor pin (OE-1729), Figure 73, used for attaching the rear sheave carrier. The lug for the pin will also be omitted from the frame rest casting as soon as pattern changes can be effected.

1. Vertical Adjustment—

Each shoulder rest support may be adjusted up or down after loosening the clamping levers (OE-1714), see Figure 73, at the hand grip. The adjustment permits the gunner to raise or lower his shoulders in relation to the gun sight.

2. Lateral Adjustments—

Each shoulder rest support may be rotated laterally with respect to the hand grip in either direction after loosening the clamping levers in the same manner as for vertical adjustment. These adjustments have two functions: They permit the gunner to shift his body sidewise for proper alignment with the gun sight and also permit swinging the arm rests in or out to obtain the proper span to fit the gunner's shoulders.

3. Shoulder Pad Angular Adjustment—

Each shoulder pad is free to rotate about the end of the shoulder piece support over a range of about 30 degrees on each side of the true vertical position. This adjustment permits the shoulder rest pads to assume a natural position against the gunner's shoulders and it will be found in most cases that both pads tend to tilt in at the top.

A movable cocking tackle anchor pin (OE-1729), Figure 73, is provided at the center of the hand grip frame to serve as an anchor for the rear sheave carrier when cocking the gun with (OE-3542) cocking tackle assembly. When using this pin it must be pushed to the extreme left side. At **all other times** it should be kept in the extreme right position for clearance purposes.

INSTRUCTIONS FOR USE—

1. With gunner in approximate position, pass shoulder strap around gunner's back and hook buckle over anchor knob on right side of shoulder piece support, see Figure 74.

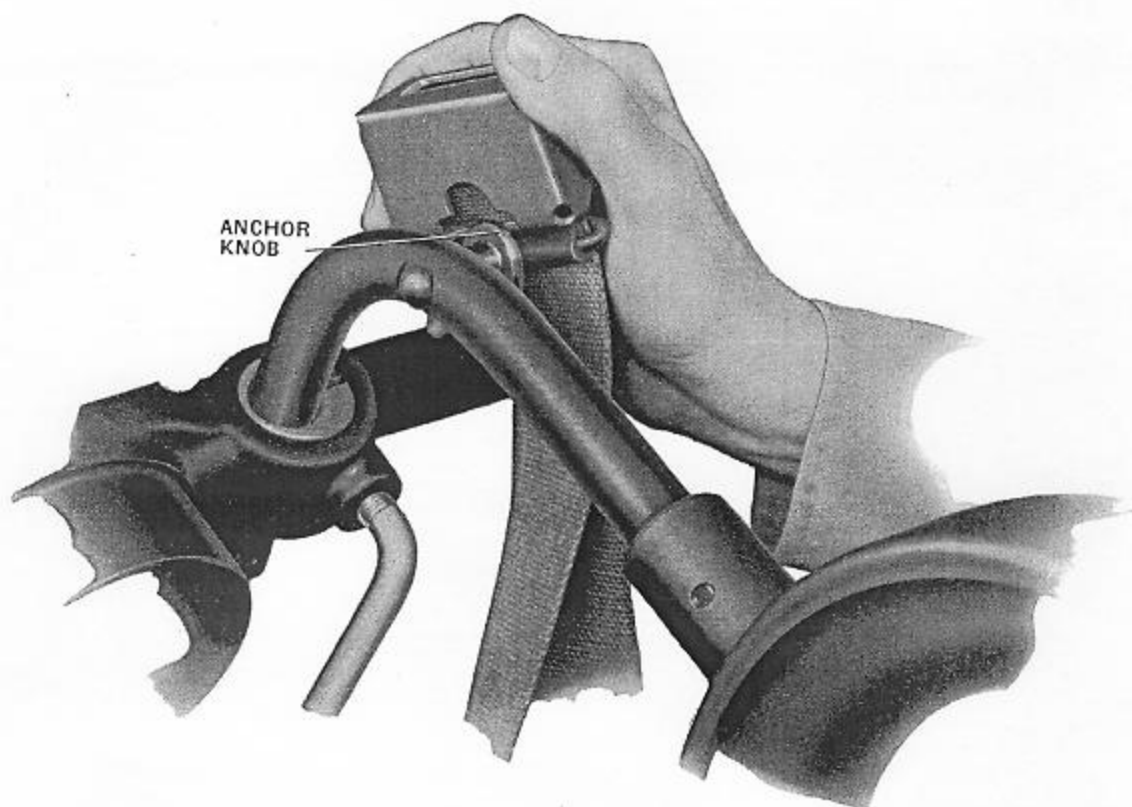

Figure 74—Hook buckle over knob

SHOULDER REST

2. Release buckle by pressing lever inward as shown in Figure 75.

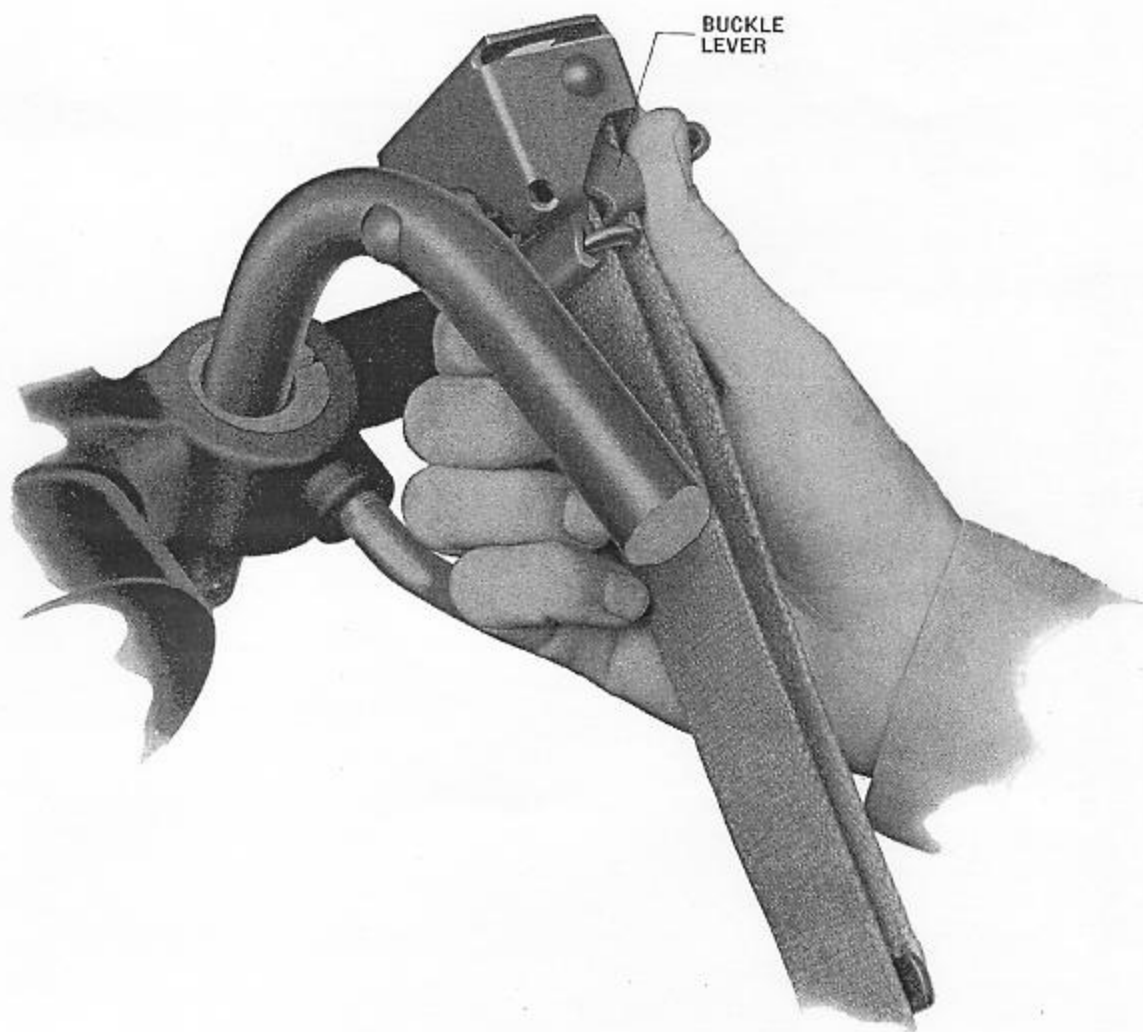

Figure 75—Press lever inward to release

SHOULDER REST

3. Pull end of strap and tighten to desired position, see Figure 76.

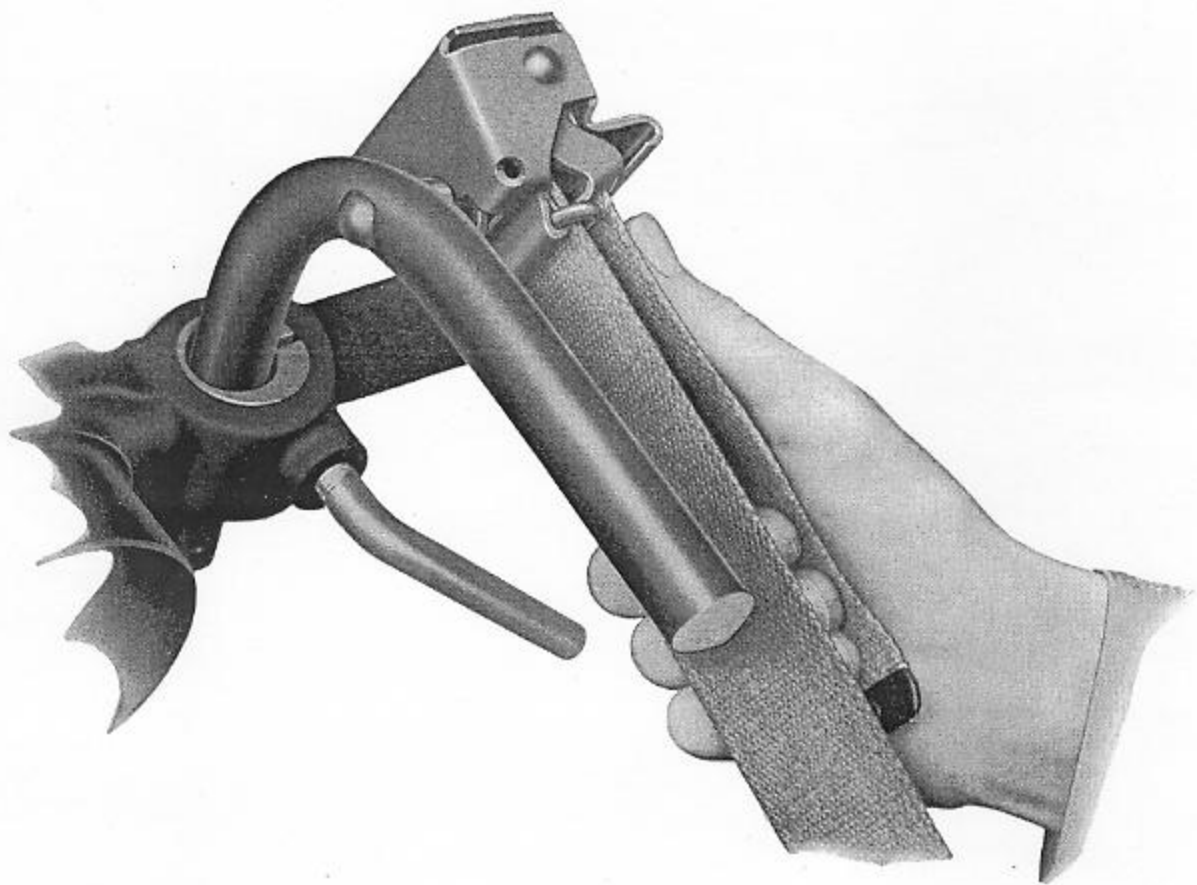

Figure 76—Pull strap downward to adjust

SHOULDER REST

4. Lock strap by outward pull on free end and release, see Figure 77.

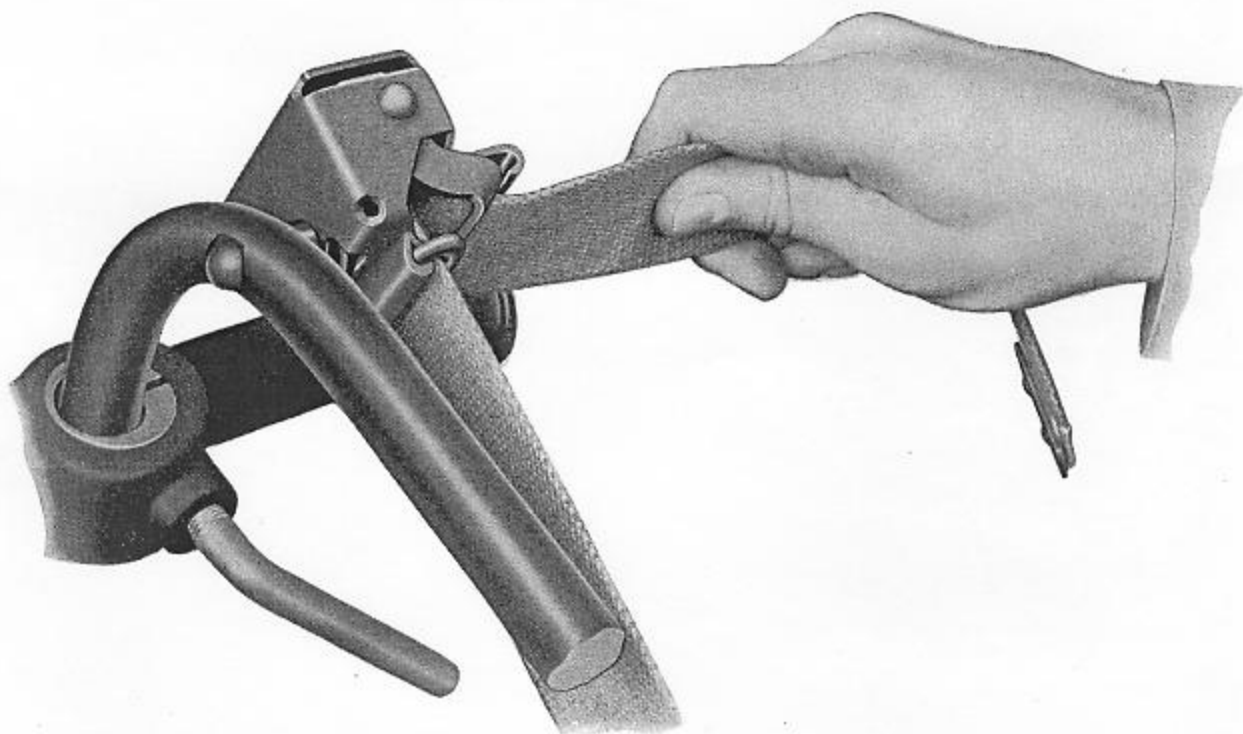

Figure 77—Pull strap outward to lock

ADJUSTMENT OF CLAMPING LEVERS

The clamping bushings (OE-1711 or OE-1712) which provide means for clamping the shoulder rest supports, are retained in the frame by stop screws (OE-1713).

Adjustment of clamping levers (OE-1714) to desired angle (and also to take up wear) can be made with clamping levers in released position by rotation of bushing stop screws in the proper direction. Stop screws should not protrude more than $\frac{1}{64}$ inch from the bosses on the hand grip frame.

NOTES

AMMUNITION

Chapter 9

AMMUNITION FOR 20 mm. A.A. GUNS MARKS 2 AND 4

There are SIX types of ammunition as follows:

(A) High Explosive, with Tracer, projectile type "HL" loaded with Pentolite, an explosive formed by combining equal parts of TNT and PETN. Color of projectile—**Blue**.

(B) Same as (A) except projectile is loaded with Tetryl. Color of projectile—**Light Grey**.

(C) **High Explosive, without Tracer**, projectile type "HB" loaded with Pentolite. Color of projectile—**Yellow**.

(D) Same as (C) except projectile loaded with Tetryl. Color of projectile—**White**.

(E) Blind loaded with Tracer. Color of projectile—**Dark Green Grey** with $\frac{1}{8}$ " wide **Yellow Band**.

(F) Blind loaded and plugged. Color of projectile—**Dark Green Grey**.

NOTE—The above colorings apply to 20 mm. A.A. Ammunition only for Mark 4 and Mark 2. Do not confuse with colors used in other ammunition.

LOADED AND FUZED PROJECTILE WITH TRACER

This projectile has about one-half of the cavity loaded with pyrotechnic tracer mixture designed to burn about $3\frac{3}{4}$ seconds. The forward part of the projectile cavity space is loaded with pressed Tetryl or Pentolite. These explosives are approximately equivalent in destructive value. The fuze used is a simple air-column type with no moving parts. Its action is initiated by impact, either head-on or glancing. The closing disc being displaced into the fuze body by impact, an air-column is instantaneously compressed and wiredrawn through an inner disc. The rate of temperature-pressure rise is sufficient to ignite lead azide, which in turn ignites pressed Tetryl in the detonator, and ignition of the burster charge is effected. The fuze is designed definitely not to function on the equivalent of 0.012 inch dulalumin plate (or lighter), but definitely to function on the equivalent of one-eighth inch mild steel plate or heavier. The fuze is not equipped with any bore-safe feature, and will act whenever the closing disc is displaced into the fuze with sufficient force. This projectile is not equipped with a self-destruction feature.

LOADED AND FUZED PROJECTILE WITHOUT TRACER

This projectile is similar to the "Loaded and Fuzed Projectile **with** Tracer" described above, but has a burster charge that is approximately twice as great.

BLIND LOADED AND TRACER TYPE OF PROJECTILE

This projectile has the burster charge cavity inert-loaded to weight, except for the tracer, and is plugged at the nose with a fuze body, assembled with no detonator.

BLIND LOADED AND PLUGGED PROJECTILE

This projectile has the burster charge cavity inert-loaded to weight, and is plugged at the nose with a fuze body assembled with no detonator.

PROPELLANT

The powder is an FNH type of nitro cellulose powder. It is a single-perforated grain with weight of charge to give 2725 foot-seconds at 90 degrees F. with standard projectiles. Surveillance and breakdown of

AMMUNITION

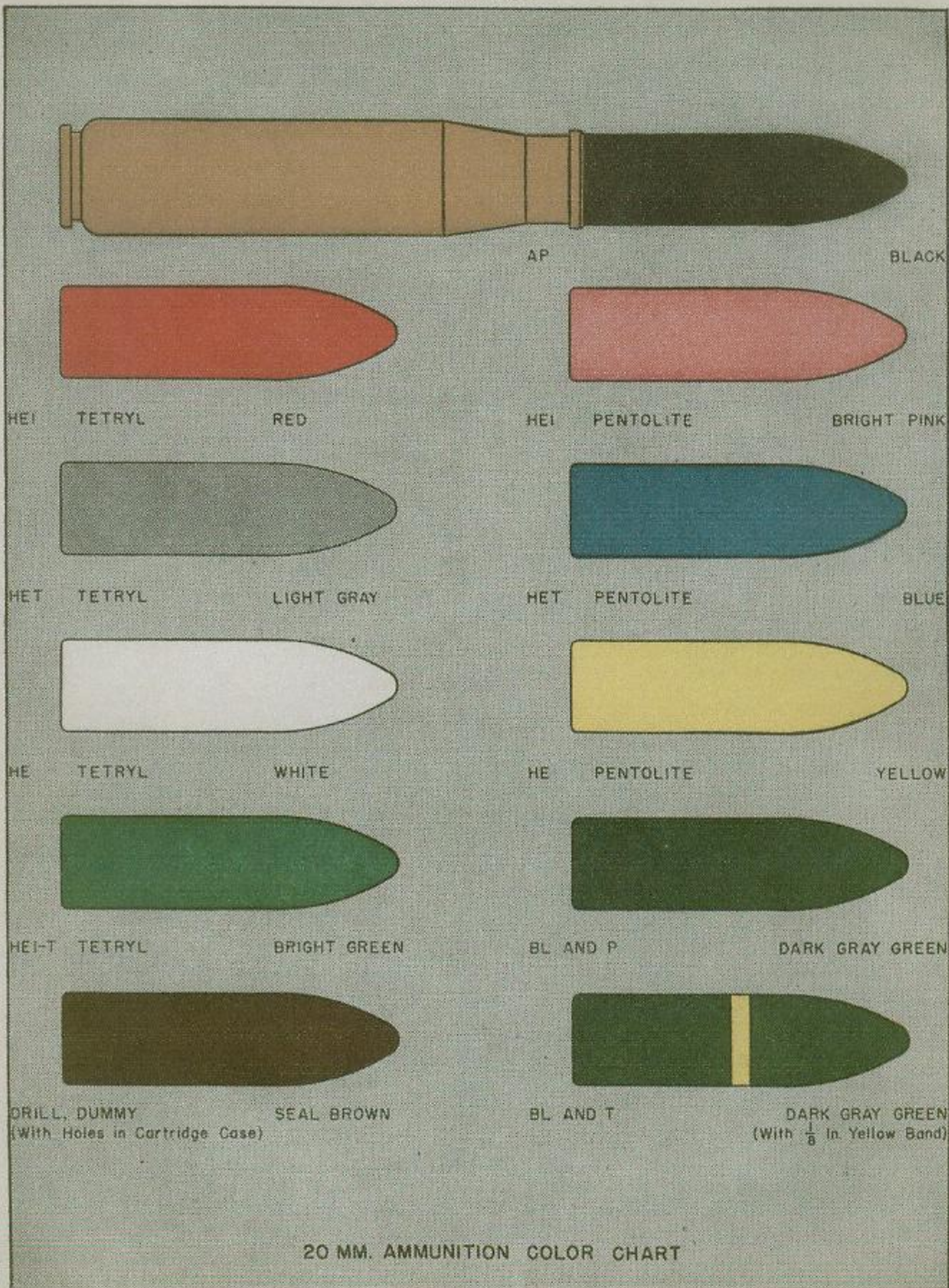

20 MM. AMMUNITION COLOR CHART

AMMUNITION MAINTENANCE

20 mm. antiaircraft cartridges are covered in separate correspondence. Instructions regarding this ammunition are similar to those currently effective regarding 1.10 inch 75 caliber ammunition.

AMMUNITION CONSTRUCTION

The cartridge case is of the usual type with a conventional percussion cap.

HIGH EXPLOSIVE SHELL

An H. E. shell must never be fired through a muzzle cover. To prevent such an occurrence the last two rounds loaded in each magazine should have blind loaded projectiles.

AMMUNITION PACKING

The first shipments of ammunition were made in wooden boxes. Later shipments are in metal boxes containing 150 rounds in each box. The completely filled metal box weighs 115 pounds. Rounds are packed in separate cardboard tubes and each tube is lined with greaseproof paper so that the grease on the cartridges will not be absorbed. The cardboard tube is open at both ends but is fitted with an inner ferrule to prevent the cartridges from clearing the tube fuze first. The cartridge is a light friction fit in the tube.

UNPACKING CARTRIDGES

Use care in withdrawing greased cartridges from their packing tubes. The most efficient way of getting them free of the tube, is to push on the nose of the fuze with a finger while firmly holding the packing tube. As previously stated, there is an inner ferrule in the tube to prevent the cartridge from clearing the tube fuze first. Pushing on the nose of the fuze starts the cartridge out of the tube, when it immediately becomes a loose fit and care must be taken not to permit the greased cartridge to come adrift and fall.

INSPECTION OF CARTRIDGES

Stoppages of the gun have occurred which appeared to have been caused by the presence of hair from ammunition packing material getting into the mechanism. Steps have been taken to eliminate this type of packing, but a large amount of ammunition has already been issued. At the first opportunity, and in any event before loading it into the magazine drums, ammunition should be examined to see that it is free of hair; and if hair or dirt is found it should be removed. If grease is removed in this process, it must be replaced.

NOTE—Pay attention to the need of a complete covering of mineral grease on all cartridge cases.

GREASING AMMUNITION

All 20 mm. A.A. Mark 2 and Mark 4 ammunition **MUST BE COMPLETELY COVERED WITH A LIGHT COAT OF MINERAL GREASE BEFORE BEING LOADED INTO THE MAGAZINE.**

The ammunition is usually packed greased. However, this grease tends to dry off. Whether cartridges are packed greased or not, they should be regreased before loading the magazine.

NOTE—A small amount of mineral grease, applied shortly before firing, to the cartridge case that is visible in the magazine mouthpiece, will assist in preventing a jam in the gun barrel.

Dry ammunition or ammunition with insufficient grease will jam in the gun chamber when fired and extraction will be very difficult, if not impossible. See Page 110 for use of torn cartridge extractor.

AMMUNITION MAINTENANCE

NOTE—Oil must not be used as a substitute for mineral grease.

Sufficient grease should be present on all cartridge cases to be easily felt by the fingers. An excess should be avoided.

CAUTION—Do not grease the rear end of the cartridge cases as the grease has a tendency to percolate inward past the percussion cap. **NEVER USE OIL.**

DROPPING CARTRIDGES

Care must be used in handling the greased cartridges. They must not be dropped or struck a heavy blow on either the nose or the cartridge base. Any cartridge that has been dropped over five feet is to be set aside and turned in to any Naval Ammunition Depot at the first opportunity.

NOTE—Rounds that have been possibly damaged as described above are not to be considered unsafe, except for firing. If used for firing, they might result in dud action and, therefore, should be refused before firing.

CARTRIDGE BAG

If prolonged firing is necessary, then the cartridge bag should be emptied frequently. A cartridge bag that gets too full gets in the way of the gun layer at high gun elevations.

NAVAL AMMUNITION DEPOT

Secure, and turn in to a Naval Ammunition Depot, all ammunition boxes, internal containers, fired cartridge cases, packing tubes and dropped or damaged cartridges. The tear strip of the top of the internal container may be discarded.

NOTES

GUN MAINTENANCE

Chapter 10

CLEANING AND OILING OF GUN MECHANISM

The cleaning and oiling of the gun should be carried out as required and when required and not at any fixed interval.

It should be realized that in this type of gun the force of explosion is absorbed in checking and reversing the forward movement of a relatively heavy bolt that is never locked. The proper functioning of the gun depends on the free movement of the recoiling parts and on the free operation of the various springs used.

Any dirt, corrosion or lack of lubrication that is present to a degree that will impede free movement and free operation will cause stoppages during firing.

CLEAN AND OIL

- (A) As soon as possible after firing.
- (B) If the gun gets wet.
- (C) If the gun gets dirty.
- (D) If there is any reason to expect corrosion to start.

In order to properly clean and oil the gun it is necessary to first partly disassemble. Instructions for Partial Stripping are given on Page 135.

LUBRICATING OIL TO BE USED

Use Medium Mineral Oil, Navy Symbol 1065 or 3065.

CAUTION—Do not add white lead, black lead, red lead or make any addition of any similar substance to the oil.

DOUBLE LOADING STOP PARTS LUBRICATION

The Double Loading Stop Plunger, Upper (OE-1080), Figure 78, and the Double Loading Stop Plunger, Lower (OE-1011 or OE-1014) in the barrel tend to become stuck with oil that is gummed by the heat of the gun. These parts should be cleaned periodically and lubricated with extra light mineral oil, Navy Symbol 1042, 2110 or 2075.

To remove the Double Loading Stop Plunger, lower (OE-1011 or OE-1014) from the barrel take out the retaining pin (OE-1012) using the special screw driver (OE-1635) in the tool roll. The plunger can then be taken out for cleaning and lubrication.

CAUTION—If the parts of the double loading stop gear become gummed or corroded, the stop plunger, lower, might not be operated, resulting in stoppage.

DOUBLE LOADING STOP GEAR AND BUFFER CORROSION

The parts of the double loading stop gear as shown in Figure 78 and also the buffer (OE-1057), Figure 80, are exposed to salt water corrosion and, therefore, require particular care in maintenance. See "Caution" note above.

SECURING BOLT LUBRICATION

When the gun is being mounted in the cradle, the inside of the securing bolt hole, the breech casing and the securing bolt itself, see Figure 13, should be thoroughly coated with Anti-seize compound, Navy Specification 52-C-19 (Int.) for protection against corrosion.

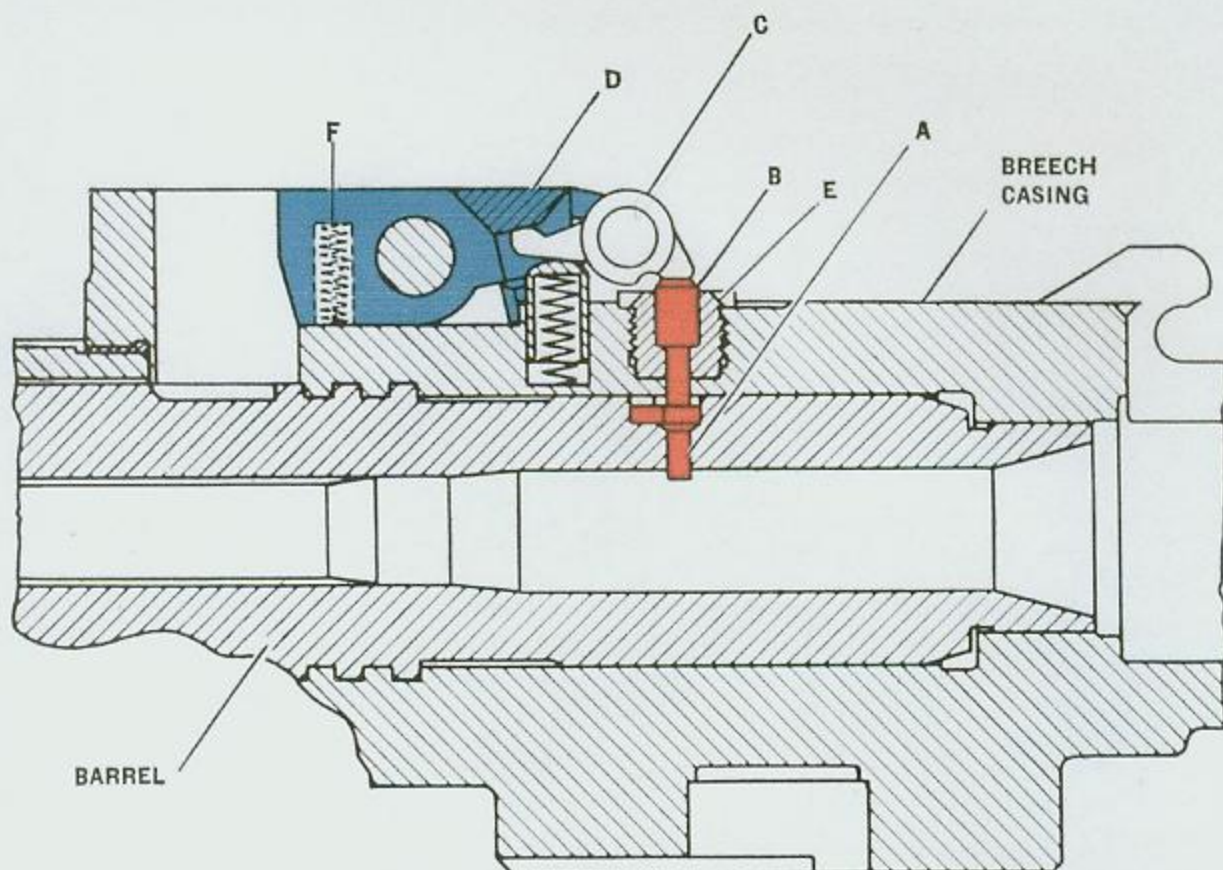

Figure 78—Double loading stop

- | | |
|---|---|
| A—Double loading stop plunger—lower (OE-1011) | D—Double loading stop (OE-1054) |
| B—Double loading stop plunger—upper (OE-1080) | E—Double loading stop guide bushing (OE-1055) |
| C—Double loading stop lever (OE-1053) | F—Double loading stop spring (OE-1336) |

GUN BARREL AND BARREL SPRING, CARE OF:

The outside of the gun barrel and the outer and inner surfaces of the barrel springs should be coated with lubricating graphite, Navy Specification 14-G-5.

NOTE—Oil should not be used on the outside of the gun barrel nor on the barrel springs as it smokes when the barrel gets hot and the smoke will interfere with the sighting of the gun.

GUN BARREL BORE AND FIRING CHAMBER, CARE OF:

The bore and firing chamber should be lightly cleaned out IMMEDIATELY AFTER FIRING, using the cleaning rod equipment (299817-5, 367516-1, and 367516-2). See Pages 130 and 131.

Place a light coat of medium mineral oil, Navy Symbol 1065 or 3065, in the bore and firing chamber.

CAUTION—Do not fire with a heavily GREASED bore or firing chamber.

The proper functioning of the gun requires easy and regular extraction of the empty cartridge case, when it is blown backward by the firing chamber gases. Care must be taken, therefore, to maintain the firing chamber walls in good condition, thereby avoiding any unnecessary friction with the walls of the cartridge case. The firing chamber walls have a high lapped polish when the barrel is issued. **FIRING CHAMBER WALLS MUST NEVER BE CLEANED WITH EMERY PAPER.**

GUN MAINTENANCE

MUZZLE COVERS

The muzzle cover should be kept on the gun barrel muzzle to prevent water or dirt from getting into the bore. It should be removed before firing, whenever practicable. It is imperative that any coating of ice one inch thick or more be removed before firing an explosive projectile. Blind loaded projectiles, two of which should be loaded last in each magazine, may be safely fired through any ice coating when necessary.

STOPPAGES

If the gun stops of its own accord for any reason other than an empty magazine, the following immediate action should be carried out:

1. Put the safety catch to "SAFE" and note whether the recoiling parts are in the forward position. If the recoiling parts are in the forward position, a misfire, a broken striker, a broken hammer, or failure to feed from the magazine, is indicated. **Safety precautions for a misfire should be observed.**

2. Examine the double loading stop. If the horns are in the down or operating position, there is a round or part of a broken case in the chamber. If the portion of the torn cartridge case left in the chamber is forward of the stop, the double loading stop will not operate and a jam will occur. See "Use of Cartridge Extracting Tool" below.

3. If the magazine is empty and the gun stops in the forward position, it may be due to sticking or sluggish action of the magazine cartridge feeder bolt which trips the interlock lever. If examination shows that this bolt does not work freely, the magazine should not be used again until the condition has been corrected.

4. Remove the magazine and recock the gun. If the magazine is difficult to remove, it will come off as the breech block is withdrawn when cocking the gun. In the event of it being impossible to remove the magazine without recocking, care should be taken to cock the gun in one continuous movement and on no account must the breech block be allowed to go forward.

5. Examine chamber and the breech face piece. If the lip of the breech face piece is broken off, a new one must be installed.

6. CLEARING OF LOADED AND FUZED PROJECTILES FROM HOT GUNS.

For information on this subject, see the latest Bureau of Ordnance safety regulations, which at the date of issue of this pamphlet, are contained in Bureau of Ordnance Circular Letter No. G15-42, dated October 19, 1942.

7. Stoppages of the gun have occurred which appeared to have been caused by the presence of hair from ammunition packing material getting into the mechanism. Steps have been taken to eliminate this type of packing, but a large amount of ammunition has already been issued. At the first opportunity, and in any event before loading it into the magazine drums, ammunition should be examined to see that it is free of hair; and if hair or dirt is found, it should be removed. If grease is removed in this process, it must be replaced.

USE OF CARTRIDGE EXTRACTING TOOL

In case a torn cartridge case is left in the firing chamber it is necessary to use the extracting tool (OE-1622), Figure 79, to remove it.

The slotted sliding sleeve should be pulled back against the shoulder of the tool and the extracting tool inserted through the torn case. The sliding sleeve at its slotted end will be slightly compressed inside the torn case and as soon as the sleeve has been pushed through the case the flanged end will expand and rest against the end of the case as shown in Figure 79.

Pull back on the extracting tool or on a bar inserted through the handle of the tool. The sleeve will be forced onto the wedge piece preventing it from collapsing and permitting the torn case to be pulled out with the tool.

GUN MAINTENANCE



CARTRIDGE CASE EXTRACTOR TOOL OE-1622

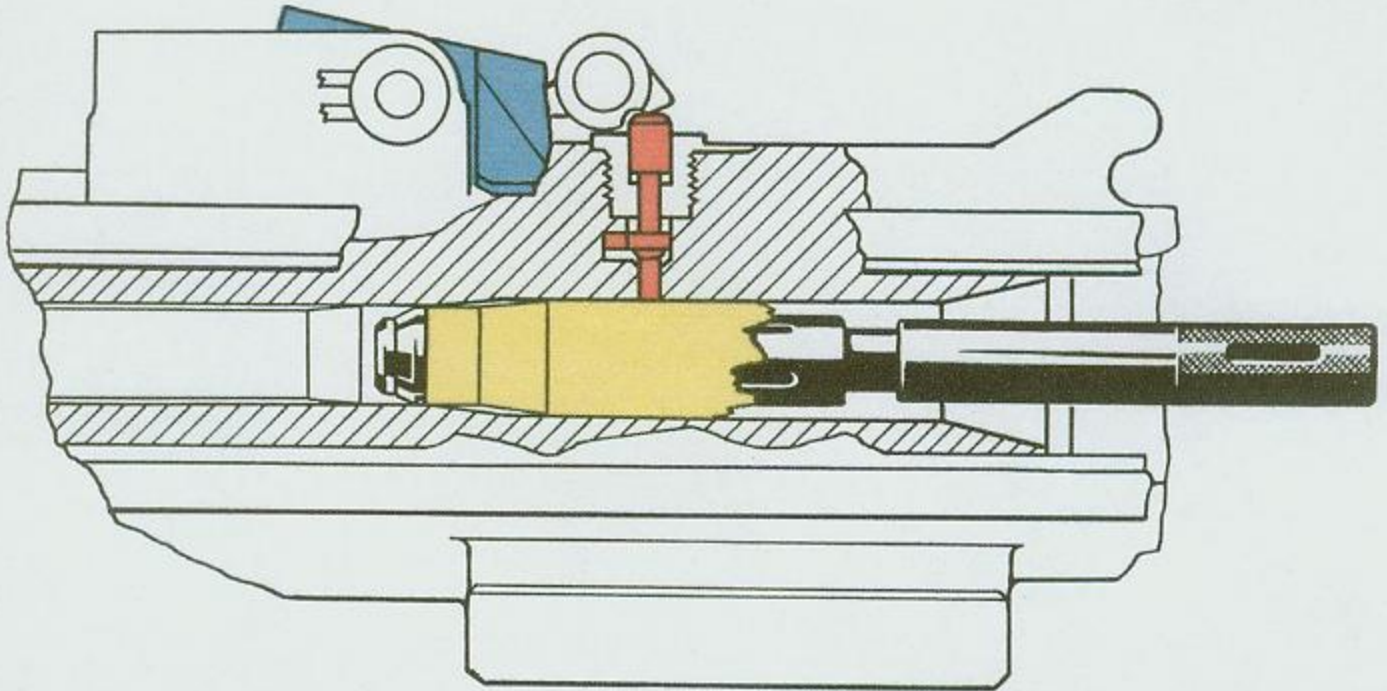

Figure 79—Using special tool OE-1622 to clear the barrel when portion of torn cartridge case is left in firing chamber

LIFE OF THE GUN BARREL

The amount of life that a gun barrel will give depends on how hot the barrel becomes during firing.

Five magazines, containing sixty rounds each, or a total of three hundred rounds can be fired continuously without harm to the gun barrel.

Nine magazines, of sixty rounds each, or a total of five hundred and forty rounds, will cause serious wear if fired continuously.

If short pauses occur between the firing of each magazine, the wear will remain small, even after several thousand rounds.

During any prolonged firing, keep the gun barrel as cool as possible, either by frequent changes with the spare barrel, or by dousing the gun barrel with water.

The bore erosion gauge assembly (367548), which is to be issued to the service, should be used after approximately each thousand rounds of firing or less. Measurements taken with this gauge, in accordance with instructions to be issued with it, will indicate when the bore wear is so great that the gun barrel should be removed from service. When a gun barrel becomes too worn, recoil is shortened so that stoppages and failures to latch back will occur.

GUN MAINTENANCE

The bore plug gauge assembly (245760), [or (299881-3) which is used with (367516-1) cleaning rod and handle assembly], which is slightly larger than the bourrelet of a projectile, should be passed through the bore occasionally to assure that no constrictions are present. If the gauge will not pass, the gun barrel should be lapped out.

GUN BARREL REPLACEMENT

The gun barrel can be easily removed and a new one installed without stripping of any other parts.

NOTE—As the clearance between the gun barrel and the breech housing must be necessarily close, the barrel may feel tight, particularly when it is hot. A special removing tool (300009-1) and asbestos gloves are provided for this reason.

GUN BARREL REMOVAL

Remove the barrel by rotating the barrel locking handle to the position marked "Unlock."

Engage the tongue of the barrel removing tool (300009-1) in the wrench slot or rib groove (depending upon whether the gun barrel is solid or ribbed), rotate it 60 degrees counter-clockwise (looking from the muzzle to the breech) and, using the asbestos gloves if necessary, pull the barrel out of the breech casing.

NOTE: A new tool is under development to facilitate the removal of gun barrels. In addition to rotating the barrel, the tool can also be used to pull the gun barrel out of the breech casing.

As soon as the tool is approved, an Ordalt will be issued to cover alterations necessary to permit its use with gun barrels now in service.

GUN BARREL INSTALLATION

Align the arrow marked "Insert" on the gun barrel with the index mark on the front face of the barrel spring case. Push the barrel into the breech casing until it bottoms. Then rotate the gun barrel 60 degrees clockwise (looking toward the breech) or until the arrow marked "Locked" is in line with the index mark on the front face of the barrel spring case. While moving the gun barrel into position, press down on the horns of the double loading stop (OE-1054). This will prevent the stop plunger in the breech casing from scoring the surface of the gun barrel. Move the locking handle into the position marked "Locked."

VIOLENT RECOILS

If violent recoils, causing metal to metal contact of the buffer against the breech casing occur habitually, and more than one lot of ammunition has been used during these metal to metal recoils, then the cause is probably a collapse of the barrel springs and not a result of ammunition loading.

A metal to metal contact always occurs between the barrel spring casing and the buffer during the last inch of recoil. However, the buffer should not normally strike the breech casing. Weak barrel springs will cause the buffer springs to be overloaded and result in metal to metal contact of the buffer against the breech casing.

A remedy is to change to the spare barrel springs. If spare barrel springs are not available then insert flat washers at the rear end of the barrel spring up to a maximum thickness of three fourths of an inch.

GUN MAINTENANCE

CAUTION—Whenever possible, keep the gun **UNCOCKED** in order to relieve the spring tension and prevent the possibility of a permanent set of the springs.

BUFFER CORROSION

If the buffer (OE-1057), Figure 80, becomes corroded it may not have the free movement necessary to transmit the last of the recoil shock to the buffer springs and the free movement necessary to assist the barrel springs on counterrecoil.

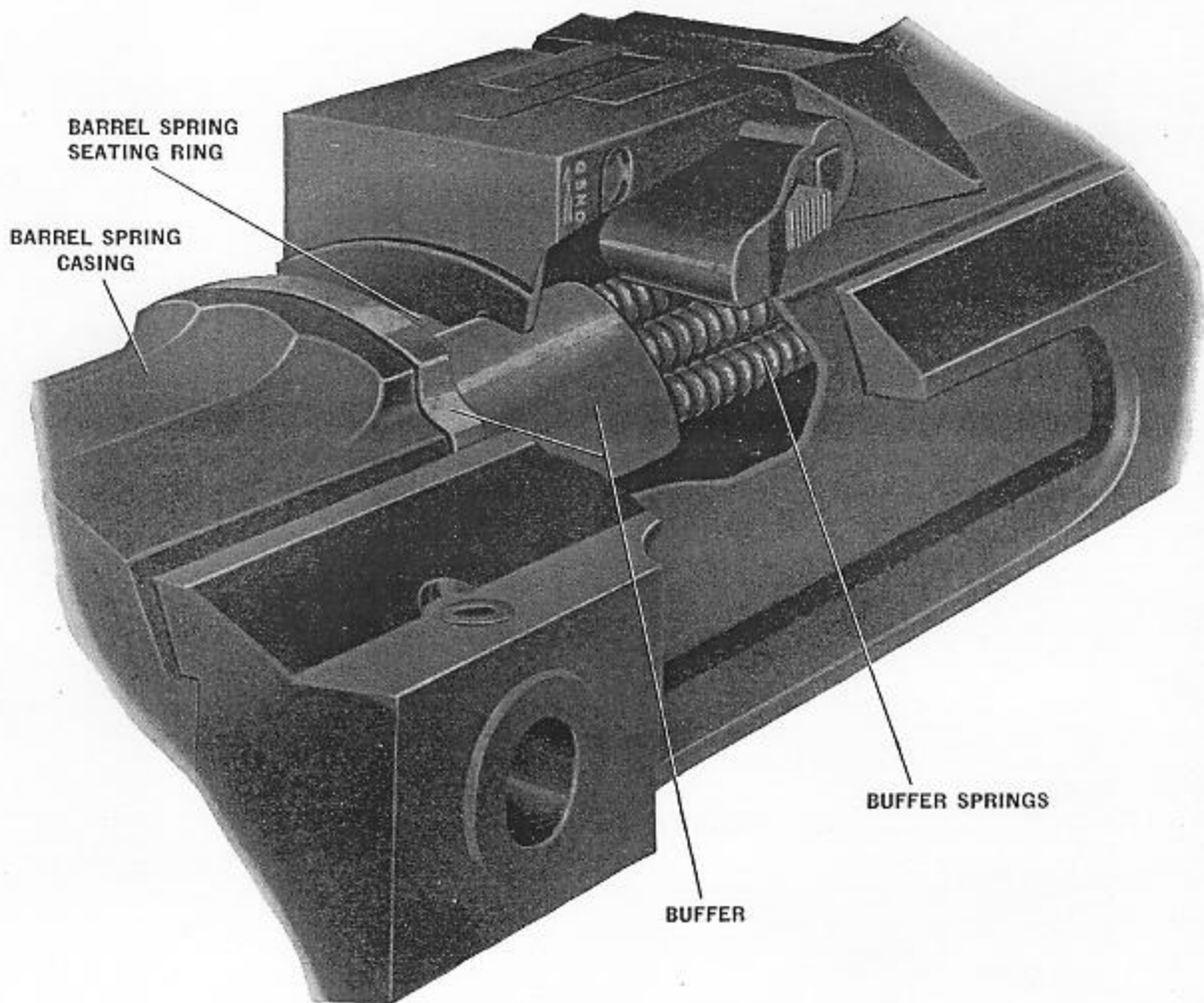

Figure 80—Recoil buffer springs

GUN MAINTENANCE

USE OF 20 mm. GUN ON SUBMARINES

Because of the conditions under which the gun is used there are new problems involved in the maintenance and lubrication of this unit. Additional care is necessary to assure efficient operation upon surfacing and to provide adequate protection to the parts while submerged.

Proper cleaning is highly essential. After firing, all parts must be cleaned and traces of rust and corrosion removed by rubbing with Diesel fuel oil. All parts must then be adequately lubricated. Due to different finishes on the parts, and in view of their peculiar operating conditions, different types of lubricants are required. The detailed instructions are as follows:

CLEANING

Strip the gun completely (see Gun Complete Stripping and Reassembly, Pages 151 to 158). A mixture of oil, water, and powder residue will be found on the internal parts of the gun. Wash all parts with Diesel fuel oil. Examine them carefully and remove all traces of rust and corrosion by rubbing with a cloth saturated with Diesel fuel oil. Then pass dry patches through the bore until thoroughly clean. All other parts should be blown dry with compressed air. Particular attention should be given to cleaning the gun barrel, barrel springs and sleeves, spring case, buffer, buffer springs and barrel spring seating ring to remove all traces of rust. **Do not use an abrasive, such as emery cloth.**

LUBRICATION

Wipe all parkerized (black) parts except gun barrel, barrel springs and sleeves, spring case, buffer, buffer springs, and barrel spring seating ring with a cloth saturated with extra light mineral oil, Navy Symbol 1042, 2110 or 2075. Apply a light coat of bearing grease (OS-1350) to all bright or cadmium plated parts, also trigger buffer springs. This grease should be applied with the paint brush supplied in the tool kit. A generous coating of this grease should be put on the trigger hook and sear contact surfaces.

The bore of the gun barrel, which requires special care, should be covered with a light coat of bearing grease (OS-1350) applied by passing a patch saturated in this grease through the gun barrel several times. The coating of grease in the bore should cover the entire surface without filling up the rifling.

NOTE—A heavy coating of grease in the bore will result in extremely high recoil with possible damage to the gun.

Powdered graphite should be well rubbed onto the surface of the gun barrel outside diameter, barrel springs and sleeves, spring case, spring seating ring, buffer, buffer springs, and the double loading stop. (The double loading stop plunger-lower in the gun barrel should be lubricated with extra light mineral oil, Navy Symbol 1042, 2110 or 2075.)

GUN MAINTENANCE

20 mm. A.A. GUN

List of Casualties Reported from Training Centers

1. BROKEN BARREL SPRING—REAR (OE-1320)

May break off ends or break three coils from rear end. The broken spring may jam the spring case and cause breech block to be held to the rear.

- (a) Change barrel spring if more than one inch is broken off rear end. The average life of the rectangular wire barrel spring is 2,500 rounds.

The recently developed round wire barrel springs (367533-1) rear and (367533-2) front have a considerably longer life.

2. BROKEN BARREL SPRING—FRONT (OE-1321)

Usually breaks about center of the spring with broken ends jamming on spring case.

- (a) Change barrel spring. The average life of the front barrel spring is 10,000 rounds.

3. JAM (Failure to Eject) CAUSED BY SHORT BLOWBACK

The empty case fails to be ejected through the bottom of the breech casing. As the breech block (OE-1304) moves forward the empty case is caught by face piece (OE-1305), jamming it between the face piece and the forward edge of the opening in the bottom of the breech casing. This stops the breech block about halfway forward, bending or breaking the breech face piece. The breech block has stripped another round from the magazine and sent it into the chamber. If the gun has fired more than 60 rounds it is hot enough that there is danger of an explosion due to the heat. (Standard safety precautions should be observed.) At one station two explosions have occurred from hot gun barrels, after cooling water had been applied for three minutes. The breech block had been let down so that no injury occurred. On inspection of one of the gun barrels it was found that the barrel had bulged just to the rear of the rifling so that difficulty was experienced when removing the barrel to clean the gun. The bulge in the gun barrel seemed to indicate that the fuze operated from the heat of the barrel and caused the projectile to explode. There were no attempts to fire after the explosion. Gun barrels damaged in this manner should not be used again.

4. SHORT BLOWBACKS WERE CAUSED BY—

- (a) Worn gun barrels—Short breech block recoils from worn gun barrels have occurred over a range from 4,000 to 20,000 rounds. **The gun barrel's useful life depends upon the manner in which the gun barrel is used as well as the number of rounds. A gun barrel that is fired continuously while hot will cause short recoils at a relatively low number of rounds.**
- (b) Grit or dirt on ammunition causing friction between case and firing chamber.
- (c) Dry cases causing friction between case and firing chamber.
- (d) Broken barrel spring jamming the spring in the spring case.

5. BROKEN HAMMER (OE-1308)

Breech block (OE-1315) moves forward when trigger (OE-1220) is pressed, gun fails to fire. When breech block is retracted the case is pulled out. Examination of the primer indicates a slight dent

GUN MAINTENANCE

caused by the striker pin (OE-1307). In some cases the guns have continued to fire and the broken hammer was found on cleaning the gun.

6. BROKEN STRIKER PIN (OE-1307)

In some cases where the hammer slot was broken the gun continued to fire and the breakage was found on cleaning the gun. If the point breaks off the pin, the gun will act the same as with a broken hammer, except that the primer will not show a dent.

7. BROKEN EJECTOR (OE-1045) (Interlock Lever Catch Recess)

The breech block cannot be released from the rear position as the magazine interlock lever will not cock. The trigger will work freely. This stoppage can be easily determined and the new ejector can be installed without removing the gun from the mount.

8. STICKY DOUBLE LOADING STOP PLUNGER—LOWER (OE-1011)

This is usually caused by chips from the cartridge cases preventing its proper operation. This part will remain in the "up" position so that double loading stop (OE-1054) will function to stop the counterrecoil. Regular cleaning of plunger (OE-1011) will eliminate some of these stoppages.

9. BENT DOUBLE LOADING STOP (OE-1054)

When the double loading stop has been hit by stopping the breech bars on counterrecoil, it may cause a binding of the fork of the double loading stop (OE-1054) on the barrel locking lever (OE-1054). Double loading stop (OE-1054) should be replaced.

10. BROKEN PARALLELOGRAM LEVER AXIS BOLT TOP FRONT (OE-1207)

This bolt breaks at the center where the spacing sleeve pin (OE-1272) passes through. The gun usually continues to operate and this breakage is found on cleaning the gun.

NOTE: A new design bolt (OE-1201) which eliminates the use of sleeve (OE-1208) and sleeve pin (OE-1272) is now in production.

11. CHIPPED SLOT IN TOP OF BREECH FACE PIECE (OE-1305)

This is usually caused by improper assembly of breech face piece retaining spring (OE-1306) allowing the face piece to turn enough so that the edges are chipped against the ejector (OE-1045).

12. DEFORMED OR TORN CARTRIDGE CASE

This casualty is usually the result of insufficient magazine spring tension, short recoil, or improper positioning of the magazine on the breech casing. The breech face piece fails to engage the base of the cartridge case and the round becomes canted with the nose down. The sharp edges of the ejector slot in the breech face piece catch the flank of the case causing deformation or tearing. If the case is torn, powder grains will be spilled into the mechanism. In some instances the round is debulleted due to the top of the face piece catching on the rotating band. The magazine should be securely locked in place and tested by shaking the magazine with the handles. If locked there will be no motion of magazine.

13. BROKEN COTTER (OE-1316)

There have been two breakages reported from one station. This allows the breech bars to spread out at the rear end jamming against the cradle.

14. BARREL NOT SECURELY LOCKED IN PLACE

The barrel was blown five feet away. No injury occurred. The barrel should be checked to insure that it is locked before firing. The gun is securely locked only when the top of the barrel locking lever (OE-1078) is flush with the top surface of the breech casing (OE-1040).

15. NO PROPELLANT CHARGE IN CASE

The primer fired sending the projectile about halfway forward in the bore of the gun barrel. No blowback occurred. When projectile was backed out the gun barrel was found to be in good condition.

16. BULGED CARTRIDGE

A cartridge which fired, bulged so much at the base end that it could not clear through the opening in bottom of breech casing. The cartridge was found to be holding the breech block halfway forward.

17. FREE TRIGGER

- (a) Same action as broken ejector. The gun will fire a few rounds then breech block will lock to rear. This is caused by a bent magazine interlock lever spring (OE-1330). Care should be taken when installing this spring as it is easily bent.
- (b) Rear parallelogram lever plunger (OE-1212) sticking so that when top lever (OE-1204) is lifted by the trigger crank (OE-1223), rear lever (OE-1203) is not forced off trigger hook (OE-1216).
- (c) Another case of free trigger was reported from a station recently which was unusual. It was found that the breech bolt (OE-1315) was held in the rearward position, but not back far enough to engage the breech bolt pawls (OE-1103) and (OE-1104) with the lower parallelogram levers (OE-1206). In attempting to pull breech bolt (OE-1315) to rear with cocking wire rope, it was found that the breech bolt was jammed in the trigger casing (OE-1202). A lanyard was placed over the forward end of the spring casing (OE-1102) and pulled rearward to remove strain of breech bars from cotter (OE-1316) and cotter was removed. When trigger casing (OE-1202) was withdrawn with the breech bolt it was found that the sear axis bolt snap ring (OE-1346) had broken and a piece of the snap ring had jammed between breech bolt and trigger casing. After this piece had been removed, the breech bolt could be moved from the spring casing and no other damage was noted. From this experience, care should be taken to see that the snap ring is in good condition and not sprung when installed.
- (d) Another case of free trigger occurred at the same station referred to in (c) where it was found that the sear (OE-1317) contacting the trigger hook (OE-1216) had become chipped and roughened so that enough friction developed between the sear and hook to prevent the hook from disengaging from the sear even after rear parallelogram lever (OE-1203) moved off trigger hook (OE-1216).

Care should be taken to see that these contacting surfaces are smooth and well lubricated.

NOTE—When continued repetition of free trigger occurs it might be advisable to pull the trigger with the trigger cover plate removed to determine which of the foregoing caused the failure. When gun is fired without trigger cover, care must be taken to have the gun trained in a safe direction during the operation. Also care must be taken that the magazine interlock fork axis bolt (OE-1224) does not move out with the cover removed.

- (e) A casualty has been reported wherein a cartridge in the magazine mouthpiece was fired while the magazine was being shipped. The forward guide lugs on the magazine were not pushed all

the way forward and the rear part of the mouthpiece struck and tripped the magazine catch (OE-1046), allowing the ejector (OE-1045) to move forward. The toe of interlock lever (OE-1074) then struck the primer of the cartridge in the mouthpiece, igniting the propellant. To avoid an occurrence of this nature it is important that the guide lugs on the magazine be pushed all the way forward in the slot in the breech casing before the rear of the magazine is lowered into place.

NOTES

NOTES

COCKING THE GUN

Chapter 11

COCKING AND UNCOCKING THE GUN MECHANISM

Cocking the gun is necessary before commencing firing and to clear jams. It is not necessary with normal operation to cock the gun when removing an empty magazine and replacing it with a new one.

There are a number of cocking methods available. The most convenient way is the cocking sheave method. All later production cradles are fitted with the sheave at the rear left corner. Accomplishment of Ordalt No. 1269 will provide the sheave on older cradles in service.

The procedure to follow in cocking and uncocking the gun mechanism by the various methods is as follows:

COCKING SHEAVE METHOD—MOUNTS WITH ADJUSTABLE HEIGHT TRUNNIONS

To Cock

This requires the use of cocking rope (OE-2029). Lower the carriage to its lowest position. Elevate the gun to the vertical position and lock in place. Attach one end of the cocking rope to the left end of the breech block cotter (OE-1316) and train the gun so that the other end of the cocking rope is in line with the cocking rope bracket near the lower end of the mount as shown in Figure 81. Then raise the carriage slightly until the rope is taut, being sure the rope is in the groove in the sheave.

Unlock the gun cradle, grasp the hand grips or shoulder rest and depress the gun until it reaches an almost horizontal position. See Figure 82. This action will pull the breech block mass backward and the gun mechanism will be cocked when the breech block pawls can be heard to click over the parallelogram bottom levers. Then ease the recoiling mass forward slowly to the latched position by elevating the gun.

To Uncock

BE CAREFUL NEVER TO SLAM THE BREECH ON AN EMPTY GUN. Lower the carriage to the lowest position. With the gun locked in the horizontal position, hook one end of cocking rope (OE-2029) to breech block cotter (OE-1316) and the other end to the cocking rope bracket on the mount. Raise the carriage until the cocking rope is taut enough to hold the breech mass from slamming forward when released.

Remove the magazine, if in place, by pressing catch lever (OE-1043) forward while lifting the rear end of the magazine clear of its catch (OE-1046) and ejector (OE-1045). Press down with any suitable tool on the end of magazine catch (OE-1046) in order to release the interlock. See Figure 40.

Unlock the cradle lock, press trigger (OE-1220) to release the recoiling mass and elevate the gun slowly to the vertical position. As the gun is being elevated, the recoiling mass is permitted to run forward, but is held from slamming by the cocking rope. Remove the rope.

NOTE—A firm grip on the hand grips or shoulder rest should be taken at this time as the full load of the recoil springs is being released.

NOTE—In the near future the method of attaching the cocking rope to cock or uncock the gun by the cocking sheave method will be revised. This will involve the use of a shorter cocking rope (299782-2) which will be attached to a new cartridge bag anchor bolt (299804-6) instead of to the cocking rope bracket on the mount. Otherwise the procedure of operation is identical to that previously described. This latter method will permit the gun to be cocked at any angle of train and with less force applied.

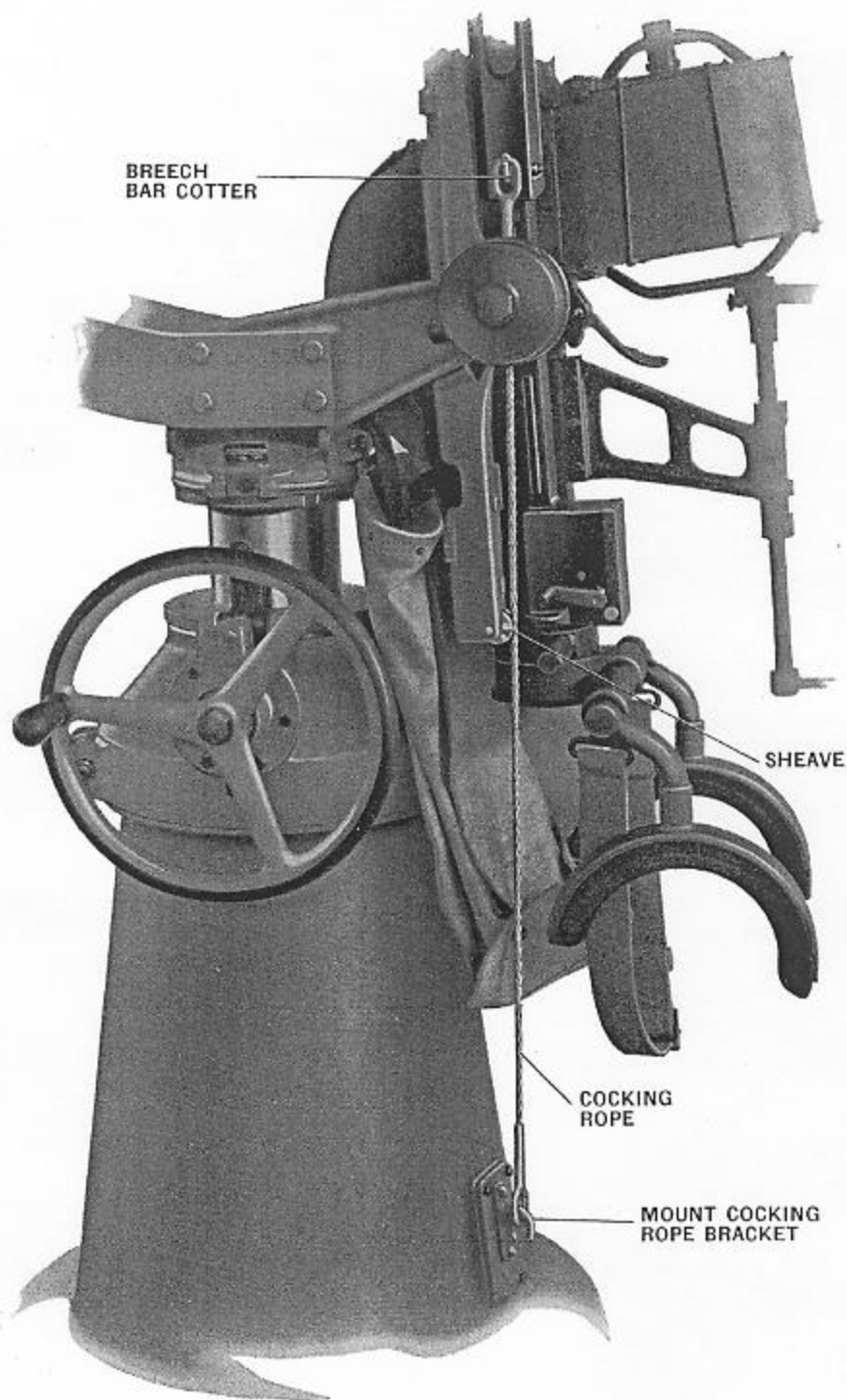

Figure 81—Cocking rope (OE-2029) attached preparatory to cocking gun

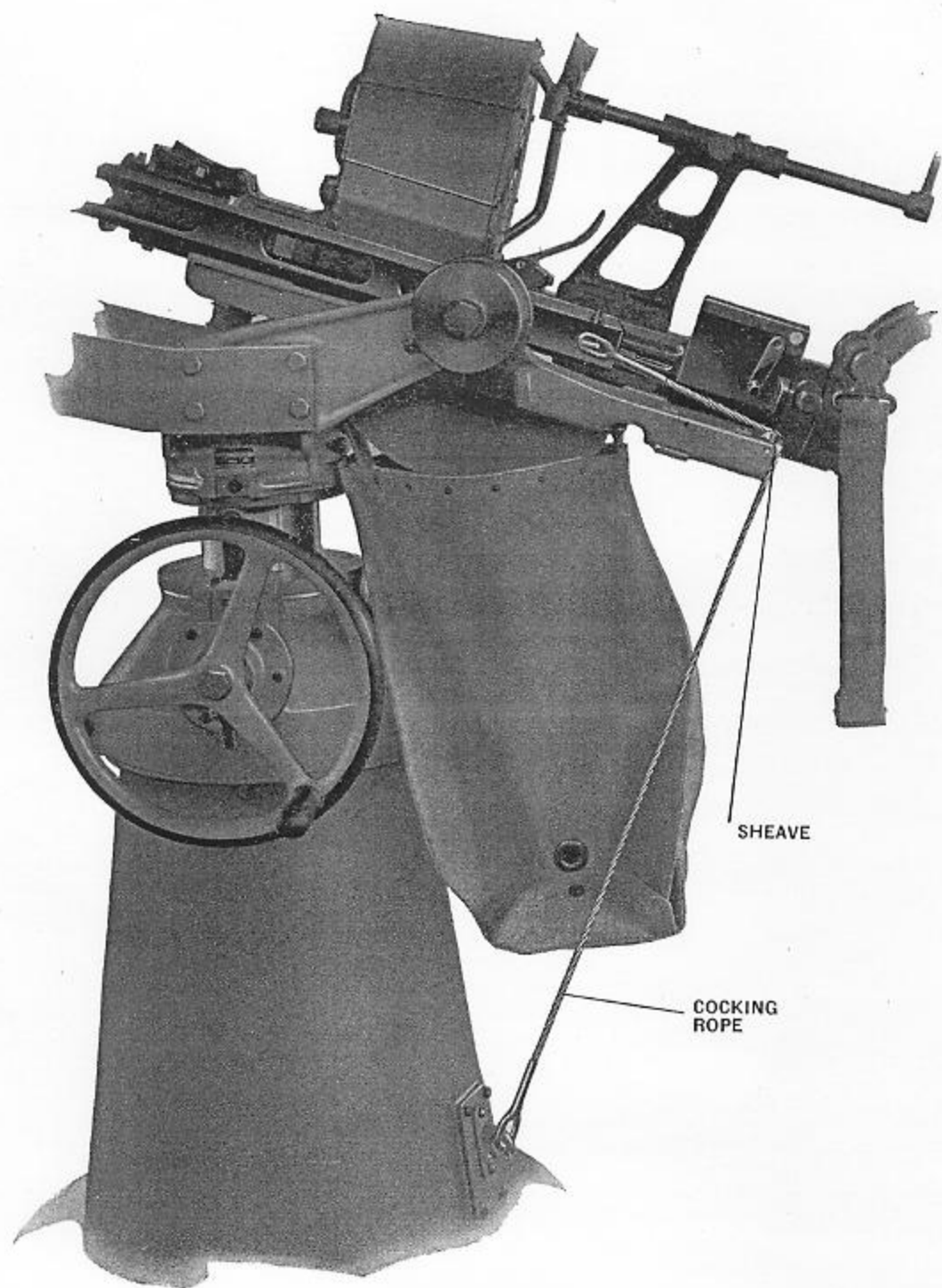

Figure 82—Cocking gun with cocking rope (OE-2029)

COCKING THE GUN

COCKING SHEAVE METHOD—FIXED HEIGHT MOUNTS

To Cock

Elevate the gun to the vertical position and lock in place. Attach one end of cocking rope (OE-2029) to the left end of breech block cotter (OE-1316) and train the gun so that the other end of the rope is in line with the cocking rope bracket near the lower end of the mount. Be sure the rope is in the groove in the sheave.

Unlock the gun cradle, grasp the hand grips or shoulder rest and depress the gun until it reaches an almost horizontal position. This action will pull the breech block mass backward and the gun mechanism will be cocked when the breech block pawls can be heard to click over the parallelogram bottom levers. Then ease the recoiling mass forward slowly to the latched position by elevating the gun.

To Uncock

BE CAREFUL NEVER TO SLAM THE BREECH ON AN EMPTY GUN. Elevate the gun and attach one end of cocking rope (OE-2029) to breech block cotter (OE-1316) and the other to the cocking rope bracket on the mount. Grasp the hand grips or shoulder rest and depress the gun until the cocking rope is taut enough to prevent the breech mass from slamming forward when released.

Remove the magazine, if in place, by pressing catch lever (OE-1043) forward while lifting the rear end of the magazine clear of its catch (OE-1046) and ejector (OE-1045). Press down with any suitable tool on the end of magazine catch (OE-1046) in order to release the interlock. See Figure 40.

Press trigger (OE-1220) to release the recoiling mass and elevate the gun slowly to the vertical position. As the gun is being elevated, the recoiling mass is permitted to run forward, but is held from slamming by the cocking rope. Remove the rope.

NOTE—A firm grip on the hand grips or shoulder rest should be taken at this time as the full load of the recoil springs is being released.

COCKING ROPE METHOD (WITHOUT COCKING SHEAVE)

ADJUSTABLE HEIGHT TRUNNION MOUNTS—CRADLES WITHOUT COCKING SHEAVE

It is necessary to raise the carriage to cock the gun mechanism and to lower the carriage to uncock it. The procedure is as follows:

To Cock

Lower the carriage to its lowest position. Elevate and lock the gun in the vertical position. Attach cocking rope (OE-2029) to the end of breech block cotter (OE-1316) and cocking rope bracket on the mount as shown in Figure 81.

Raise the column with the handwheel or pump pedals (depending on the type of mount, Mark 4 or Mark 6) until the breech pawls are heard to click over the parallelogram bottom levers as the breech block is pulled rearward. Then ease the recoiling mass slowly forward to the latched position by lowering the column and remove the cocking rope.

To Uncock

Lower the carriage to its lowest position. Elevate and lock the gun in the vertical position. Attach one end of cocking rope (OE-2029) to breech block cotter (OE-1316) and the other end to the cocking rope bracket on the mount.

COCKING THE GUN

Raise the column with the handwheel or pump pedals (depending on the type of mount, Mark 4 or Mark 6) until the rope is taut enough to keep the breech mass from slamming forward. If in place, remove the magazine by pressing catch lever (OE-1043) forward while lifting the rear end of the magazine clear of its catch (OE-1046) and ejector (OE-1045). Press down with any suitable tool on the end of magazine catch (OE-1046) in order to release the interlock. See Figure 40.

Press trigger (OE-1220) to release the recoiling mass and at the same time slowly lower the column to permit the breech mass to be eased forward. Remove the cocking rope when the gun is uncocked.

COCKING LANYARD (299905) MARK 3

This type gun cocking device has a stirrup which slips over the end of the gun barrel and a lanyard attached to each side. The lanyards are knotted to provide hand holds. See sketch on page 209.

To cock the gun the stirrup is placed over the end of the barrel and one or two men pull on each lanyard until the breech mass is pulled back into position.

HOOK AND ROPE COCKING TOOL (OE-3530) MARK 4

The single lanyard type has a hook attached to one end. There are also several knots in the lanyard to provide hand holds. The hook is attached to the left end of breech block cotter (OE-1316) and the gun is cocked by two or three men pulling on the lanyard. See sketch of lanyard on page 208.

BLOCK AND TACKLE (OE-3542) MARK 2

Another type of gun mechanism cocking device is the block and tackle type. This was designed particularly to clear severe jams and can be used by one or more men.

It is attached to the left side of the gun mechanism by engaging the head of shoulder pin (OE-3556) in the rear slot in the left breech bar and attaching the hook on the rear sheave carrier over the shoulder rest piece frame tube on Mark 2 and Mark 4 shoulder rest. On Mark 5 and Mark 5 Mod. 1 shoulder rests the hook is engaged over the sliding anchor pin (OE-1729).

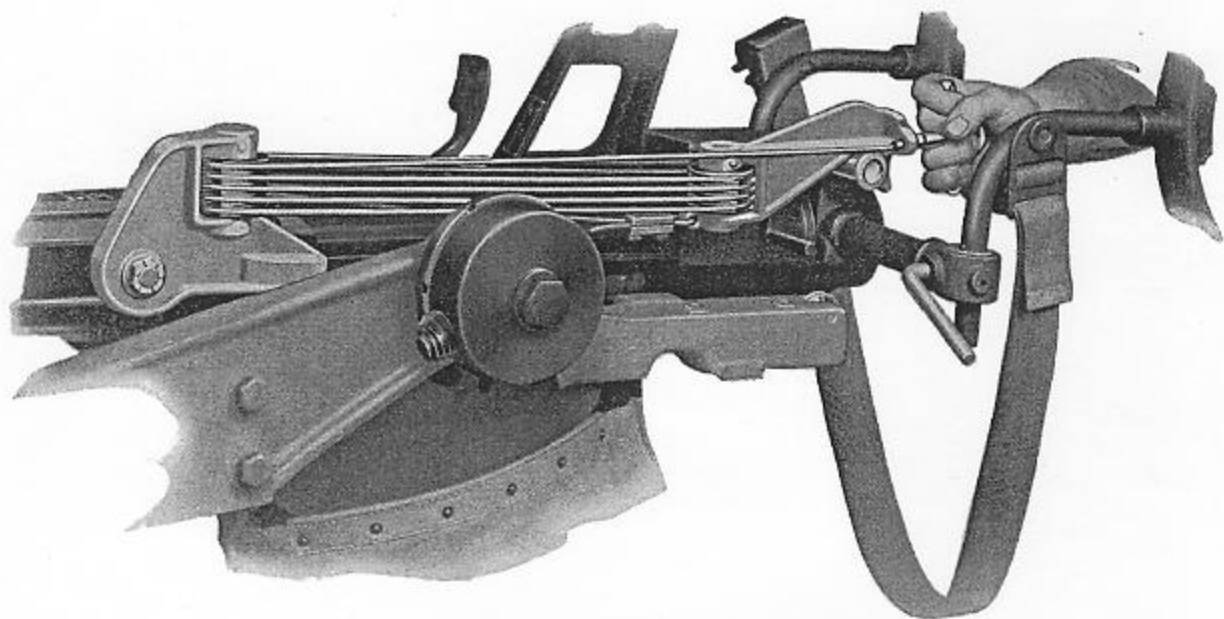

Figure 83—Cocking gun with block and tackle (OE-3542)

To Cock

Remove the magazine. Lock the gun mechanism in the horizontal position. Attach the tool as instructed above. Then grasp the handle and pull backward, as shown in Figure 83 until the breech pawls are heard to click over the parallelogram bottom levers. After the click is heard, check by easing up on the handle.

In cases of severe jams or when the effort of more than one man is required, the hook on Mark 4 gun cocking tool can be engaged in the hole in the handle to pull back the breech mass.

To Uncock

With the cocking tool attached as described above, pull the handle back as far as possible to pull the cable taut enough to prevent the breech mass from running forward when released. Remove the magazine, if in place, by pressing catch lever (OE-1043) forward while lifting the rear end of the magazine clear of its catch (OE-1046) and ejector (OE-1045). Press down with any suitable tool on the end of magazine catch (OE-1046) in order to release the interlock. See Figure 40.

Press trigger (OE-1220) to release the recoiling mass and at the same time slowly ease up on the handle of the cocking tool to allow the breech mass to run forward.

RATCHET TYPE COCKING TOOL MARK 1

Still another cocking device, which is in limited service, is the ratchet type cocking tool. See Figure 84. This can be used only on gun mechanisms which are fitted with the hand cocking catch plate (OE-1044) on the rear end of the right breech bar, and the separate hand grips (OE-1036). The tool is attached to the rear end of the gun after removing the shoulder rest from the hand grips.

To Cock

After attaching the device to the hand grips, attach the hook (E), Figure 84, on the end of the chain to catch plate (OE-1044) (D) on the right breech block. Move the ratchet handle (A) back and forth until the breech pawls can be heard to click over the parallelogram bottom levers when the breech block has been pulled far enough to the rear. Then ease off on the handle until the sear (OE-1317) engages trigger hook (OE-1216).

To Uncock

After attaching the device to the hand grips as instructed under "To Cock," move the ratchet handle (A) until the chain is taut enough to hold the breech mass from moving forward. If in place, remove the magazine by pressing the catch lever (OE-1043) forward while lifting the rear end of the magazine clear of its catch (OE-1046) and ejector (OE-1045). Press down with any suitable tool on the end of magazine catch (OE-1046) in order to release the interlock. Press trigger (OE-1220).

Pull on the handle and then release the holding pawl by pressing forward on the pawl lever (B). Hold this lever down and at same time allow handle to rotate slowly forward. Apply finger pressure to the handle pawl (C) and return the handle to the starting position. Repeat above operation until the breech mass has been moved forward.

COCKING THE GUN

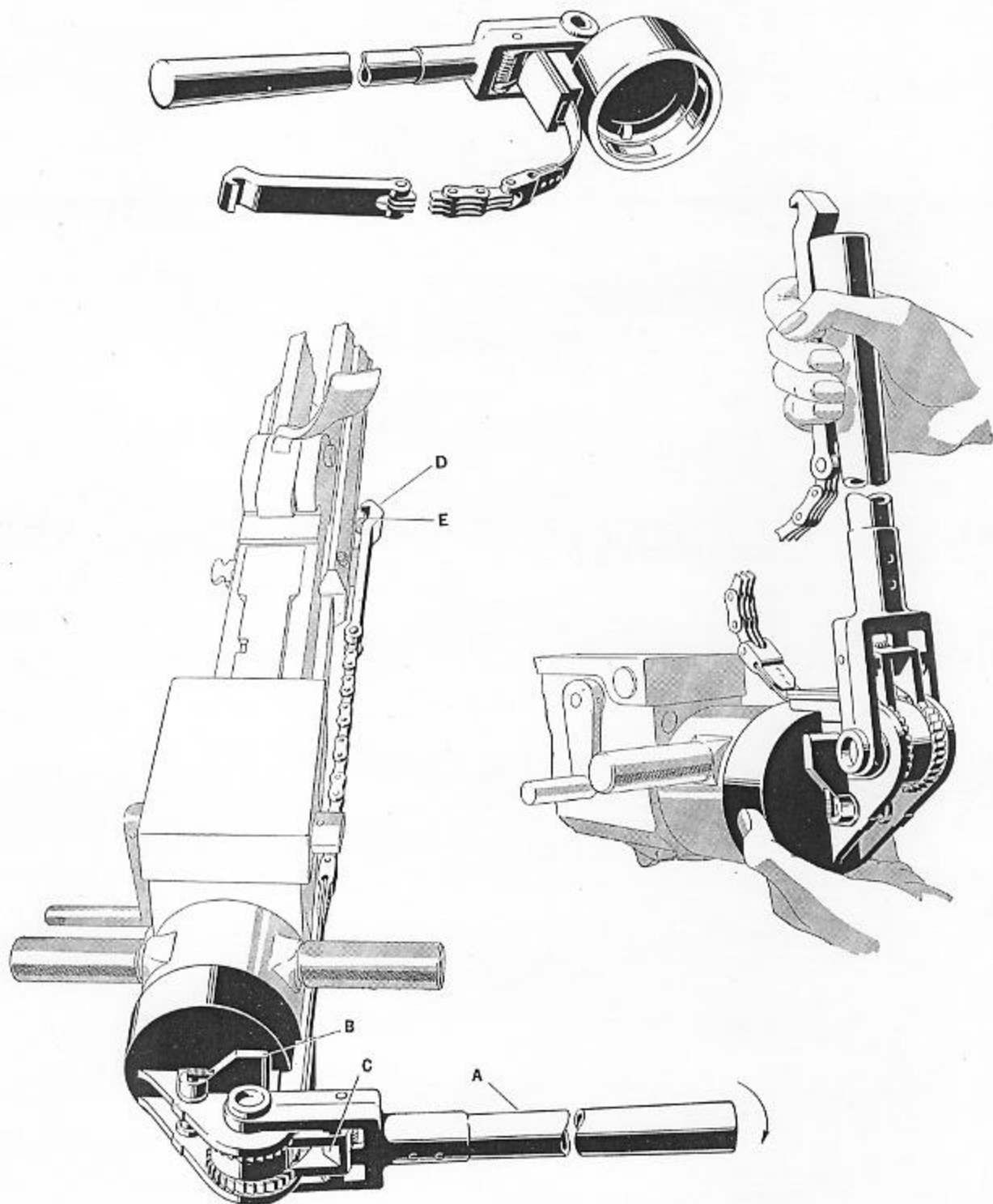

Figure 84—Hand Cocking Tool Mark 1

GUN TOOLS

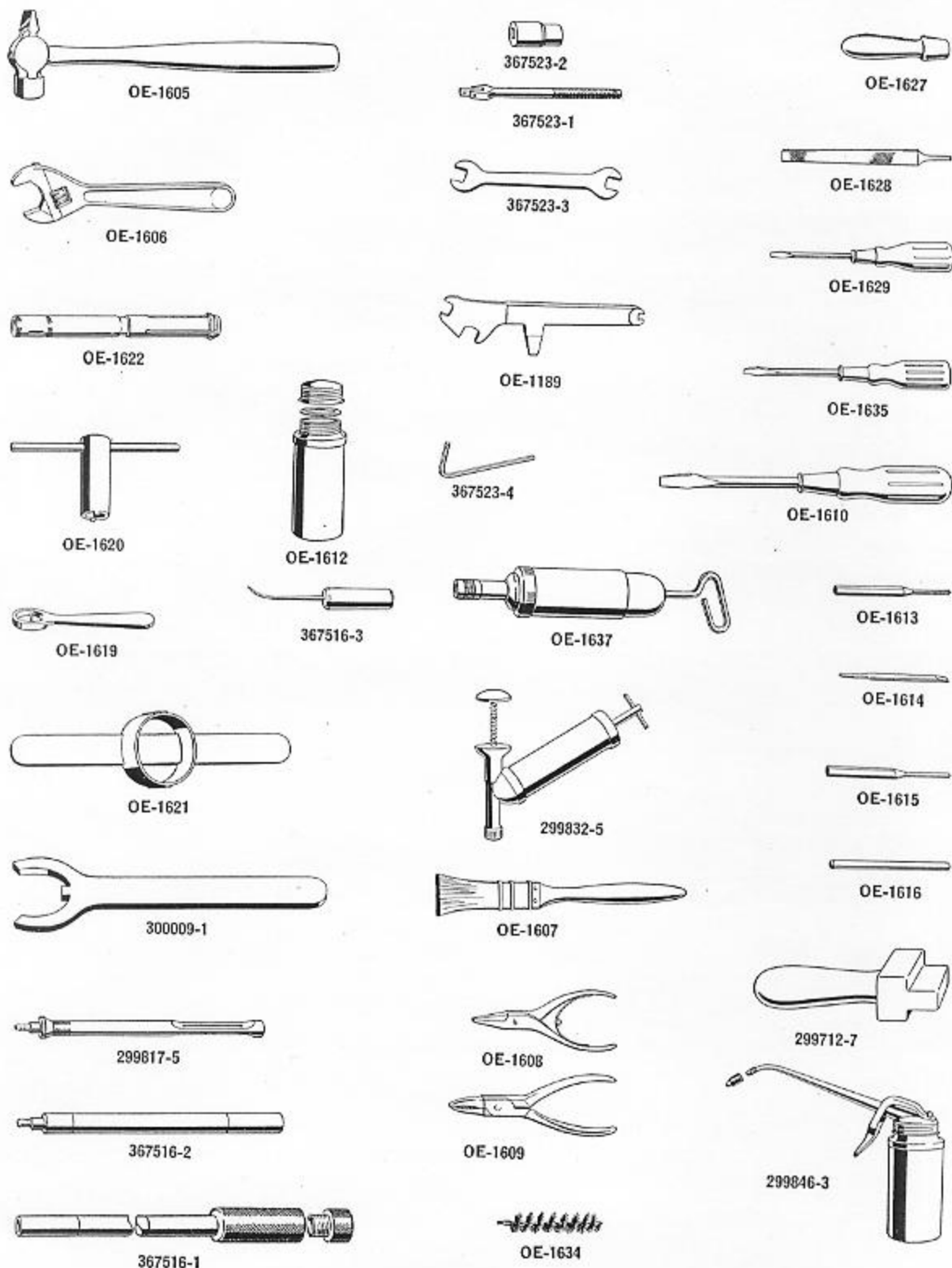

Figure 85—Gun tools

PARTIAL STRIPPING

Chapter 12

BREECH FACE PIECE REMOVAL

The breech face piece (OE-1305) can be removed from the breech block without removing the breech block from the gun mechanism. This operation is facilitated by the use of face piece removing tool (367516-3), see Figure 86.

On mounts **with the cocking sheave**, the breech block can be partially retracted by using the cocking sheave methods described on pages 122 and 125.

On Marks 4 and 6 mounts **not equipped with the cocking sheave**, the breech block can be partially retracted by elevating the carriage as described on page 125. By this method the column can be raised until the breech block has been drawn back five or six inches from the uncocked position.

On Mark 5 mounts **without the cocking sheave** lock the cradle in either the horizontal or vertical position. Attach one end of cocking rope (OE-2029) to the breech bolt cotter and draw the breech block back five or six inches from the uncocked position. Keep the breech block drawn back by winding the cocking rope across the back of the hand grips—around the right hand grips and back across the left hand grips. Repeat this winding until the rope is secured so that the breech block cannot move forward.

Release breech face piece securing spring (OE-1306) from locking notch in face piece by inserting tool (367516-3) through the openings in the left breech bar and breech casing and slide it between the spring and breech block. The pointed end of the tool can be engaged under the spring through a groove about $\frac{1}{4}$ inch aft of the forward end of the breech block. See Figure 86.

Slide the tool under the spring for about $\frac{1}{2}$ inch. Then engage face piece spanner (OE-1619) on the breech face piece and turn to one side as far as possible, see Figure 87. Remove the spanner and continue to

The following are the names of the gun tools in Figure 85.

OE-1605	8 Oz. Cross Peen Hammer	OE-1629	Screw Driver—Small
OE-1606	Adjustable Wrench	OE-1634	Cleaning Rod Brush
OE-1607	Brush	367516-1	Cleaning Rod and Handle Assembly
OE-1608	Pliers—External*	367516-2	Cleaning Rod Ejector Assembly
OE-1609	Pliers—Internal*	299817-5	Cleaning Rod Rag and Brush End Assembly
OE-1610	Screw Driver—Large—5-inch	OE-1635	Screw Driver—For Barrel Screw
OE-1612	Grease Container	OE-1637	Grease Gun—or
OE-1613	Punch—Small	299832-5	Grease Gun
OE-1614	Punch for Removing Hammer Plate	299846-3	Oiler
OE-1615	Punch—Large	300009-1	Barrel Removing Tool
OE-1616	Drift	OE-1189	Sight Universal Spanner
OE-1619	Breech Face Piece Spanner	367523-1	Sight Socket Wrench Handle
OE-1620	Double Loading Stop Bushing Spanner	367523-2	Sight Socket Wrench
OE-1621	Barrel Spring Seating Ring Spanner	367523-3	Sight Double Open End Wrench
OE-1622	Cartridge Case Extractor Tool	367523-4	Sight Allen Type Wrench
OE-1627	File Handle	299712-7	Magazine Loading Tool
OE-1628	5-Inch File	367516-3	Breech Face Piece Removing Tool

*These pliers are not hardened and should be used only for the purposes intended.

PARTIAL STRIPPING

turn the face piece about 90° or $\frac{1}{4}$ turn, using drift (OE-1616) and hammer (OE-1605).

Pull the face piece out of the breech bolt.

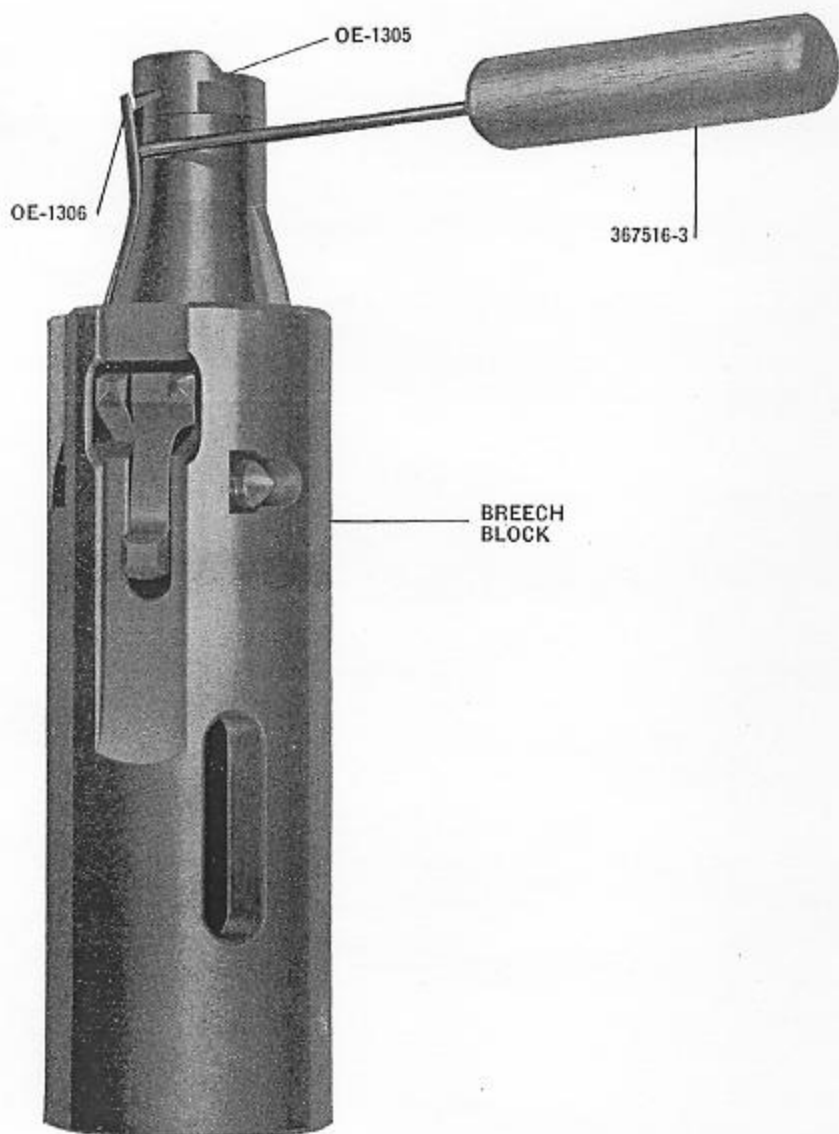

Figure 86—Tool (367516-3) inserted between breech block and securing spring

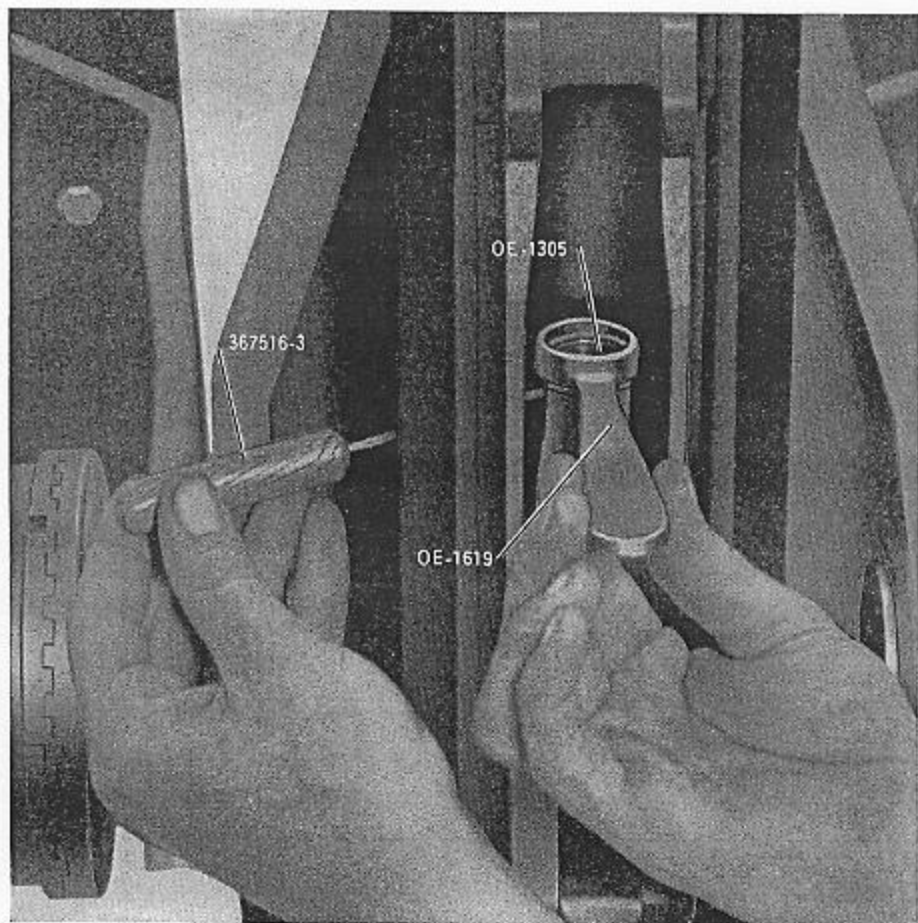

Figure 87—Turning face piece (OE-1305) with spanner (OE-1619)

PARTIAL STRIPPING

INSTALLING FACE PIECE (OE-1305)

If the face piece tool was removed from the breech block, reinsert it between the securing spring and breech block. Place the face piece in the end of the breech block and tap it into place with the drift if necessary. Remove face piece tool (367516-3). Lock the face piece in the breech block by tapping it back into place with hammer (OE-1605) and drift (OE-1616) engaged in the groove in the face piece. Continue to turn the face piece until the ejector grooves in the face piece and breech block are in alignment. See Figure 88.

Check position of face piece to see that securing spring is locked in place by placing spanner (OE-1619) on the face piece and moving it from side to side. If there is no movement, the spring is properly engaged.

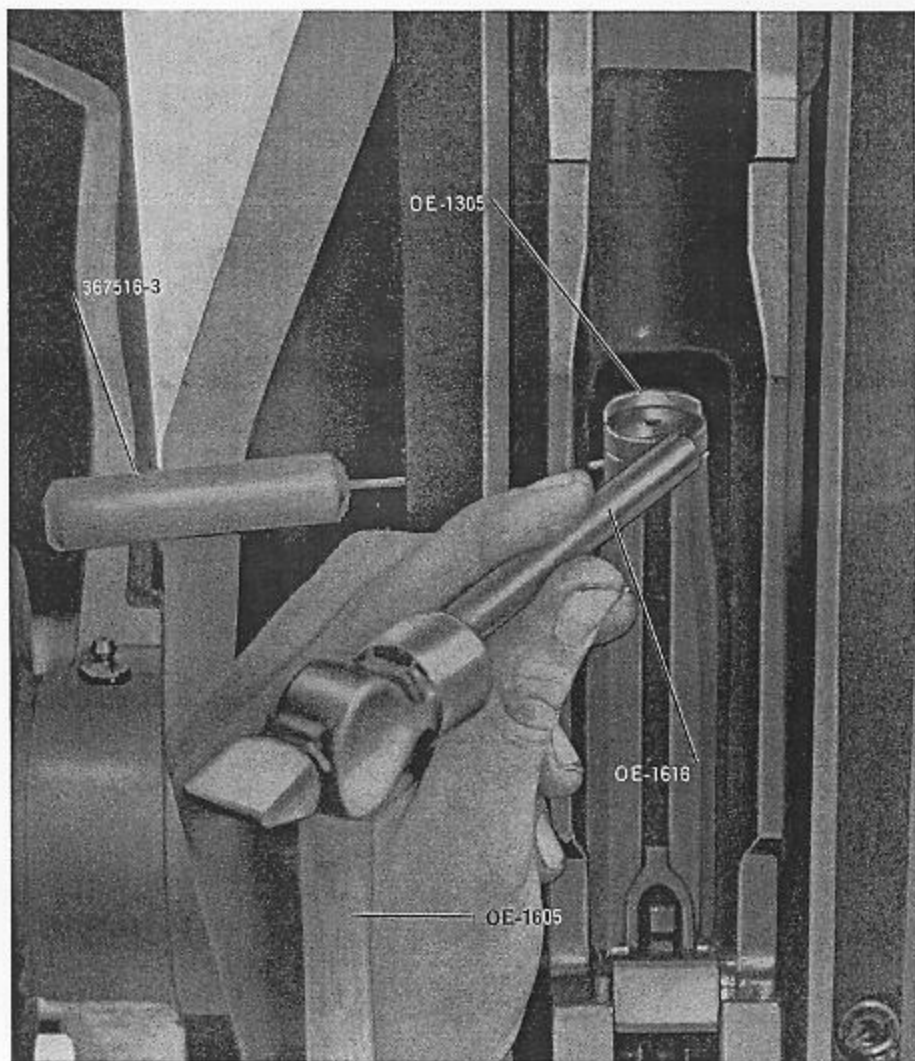

Figure 88—Tap face piece into place with drift (OE-1616)

PARTIAL STRIPPING

PARTIAL STRIPPING—SUFFICIENT FOR ROUTINE CLEANING AND LUBRICATION

NOTE—These instructions should be read in conjunction with the general assembly drawing of the Gun, Plate 1 and the List of Parts, pages 163 to 213.

Each part mentioned in these instructions for stripping or reassembly is identified by its "OE" or part number, shown on the General Assembly Drawing, Plate 1 and in the List of Parts, pages 163 to 213.

The Parts list gives the "OE" or "Part" numbers and the corresponding "Item" number. "OE" and "Part" numbers identify Parts used on the Mark 4 Gun. "Item" numbers identify Parts used on the Mark 2 Gun.

Operation Number

1. UNCOCKING THE GUN

Remove the magazine. Uncock the gun mechanism by any of the methods described in Chapter 11. BE CAREFUL NEVER TO SLAM THE BREECH MASS ON AN EMPTY GUN.

2. REMOVAL OF BARREL SPRING CASE AND COTTER SECURING BOLTS AND RETAINERS

(A) Gun mechanism removed from cradle

(a) Split type retainer (OE-1324), Figure 89

(1) Barrel spring case and cotter securing bolt retainers:

Press the upper ends of the retainers together and remove them from the bottom. Remove bolts from the top.

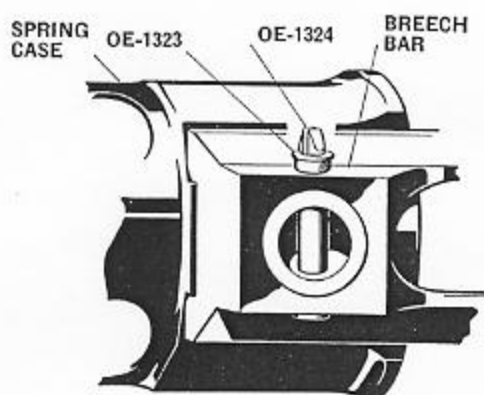

Figure 89—Split pin
type retainer (OE-1324)

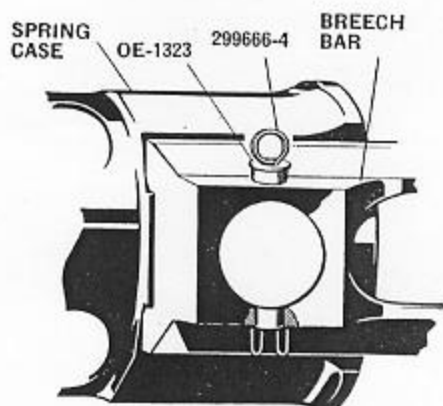

Figure 90—Round wire
type retainer (299666-4)

PARTIAL STRIPPING

Operation
Number

(b) Wire spring type retainers (299666-4), Figure 90

(1) Barrel spring case securing bolt retainers—spring case with hollow trunnions:

Press the free ends of the retainers together and push the retainers up slightly to hold the ends inside the hollow bolts. See Figure 91. Hold the bolts from moving up at the same time as care must be exercised to prevent the ends snapping into the hollow part of the trunnion when withdrawing the bolts and making their removal difficult. Remove the retainers and bolts together from the top.

(2) Barrel spring case and cotter securing bolt retainers—spring case with solid trunnions:

Press the free ends of the retainers together and withdraw the bolts and retainers together from the top. See Figure 92.

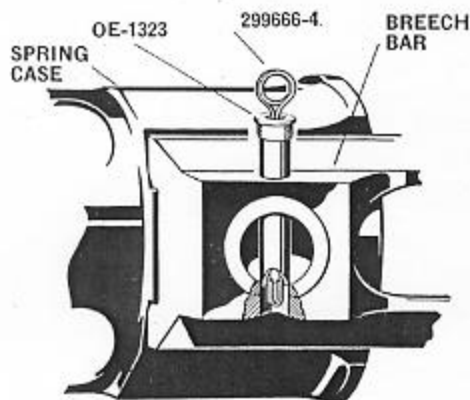

Figure 91—Draw free ends of retainer up inside of bolt

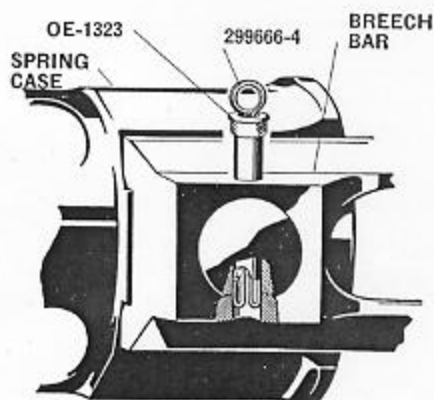

Figure 92—Remove securing bolt and retainer together

(B) Gun Mechanism Attached to Cradle

(a) Split type retainers (OE-1324)

(1) Barrel spring case securing bolt retainers:

Press the upper ends of the retainers, see Figure 89, together and remove them from the bottom. Remove bolts from the top.

(2) Cotter securing bolt retainers:

If the cradle has the elongated holes directly beneath the retainers, the retainers can be removed by pressing the upper ends together and pushing them down through the holes. Newer cradles have these holes in them. Accomplishment of Ordalt No. 1366 will provide the holes in cradles now in service.

PARTIAL STRIPPING

Operation Number

(b) Wire spring type retainers (299666-4), Figure 90

(1) Barrel spring case securing bolt retainers—spring case with hollow trunnions:

Remove the same as described in (A) (b) (1).

(2) Barrel spring case securing bolt retainers—spring case with solid trunnions:

Remove the same as described in (A) (b) (2).

(3) Cotter securing bolt retainers:

Grip the loop of the retainer and exert a light upward pull. Reach the first finger of one hand under the breech bar and press one end of the retainer toward the center of the hollow securing bolt while there is a slight upward pull on the loop of the retainer. The end of the retainer should be felt to jump up slightly and stay in position against the end of the securing bolt. If it does not stay in position, rotate the retainer one-half turn and press the opposite end of the retainer toward the center of the bolt. **One end of the retainer is longer than the other and this long end should stay in position against the end of the bolt as long as there is an upward pull on the retainer.** When the long end of the retainer is in position against the end of the bolt, continue to pull upward on the loop and at the same time rotate it one-half turn. Push the other free end of the retainer toward the center of the securing bolt and withdraw the two parts together from the top. Removal will be similar to that shown in Figure 92.

3. BARREL SPRING REMOVAL

Secure cradle in horizontal position. Remove **right front** and **left rear** securing bolt retainers (OE-1324 or 299666-4) and bolts (OE-1323) as described in Operation 2. Slide the right breech bar assembly (OE-1313) off the spring case (OE-1102 or OE-1105)* at the same time withdrawing breech bolt cotter (OE-1316) clear of the left breech bar assembly (OE-1312). Slide the assembly of spring case and left breech bar, barrel springs and spring sleeves off the muzzle end of the gun barrel.

Gun mechanism may have to be removed for this operation if the cradle does not have the elongated holes for the cotter securing bolts.

4. HAND GRIPS REMOVAL

Press the hand grip retaining catch and remove the hand grips by unscrewing counter-clockwise. The hand grips cannot be removed while the gun mechanism is mounted in the cradle unless the cradle is the new short type Mark 2 Mod. 2, Mark 4 Mod. 2 or Mark 5, or unless it has been shortened through the accomplishment of Ordalt No. 1366.

*On later model gun mechanisms a new welded type barrel spring case (OE-1105) is used in place of the former case (OE-1102) and barrel spring sleeve—front (OE-1318). In the new case the barrel spring sleeve—front is an integral part of the case and the separate front sleeve (OE-1318) is not used. See Figures 99 and 100.

5. TRIGGER PARTIAL STRIPPING

Slide the trigger cover plate (OE-1233) off to the rear. Pull out the trigger casing (OE-1202) to the rear complete with the trigger gear and trigger buffer springs (OE-1326). Remove the trigger buffer springs (OE-1326). Remove the trigger snap ring (OE-1238) using the special pliers in tool roll. Pull

PARTIAL STRIPPING

Operation Number

the assembled trigger hook holder (OE-1215) out to the rear. The trigger hook (OE-1216) on its axis bolt (OE-1217) and its spring (OE-1343) will be pulled out with the trigger hook holder.

NOTE—A strong pull is required.

Care should be exercised in removing the trigger hook holder snap ring (OE-1238), not to spread it too far. Casualties have resulted from failure of the snap ring during operation. This can often be attributed to weakening of the snap rings during removal or installation.

The pliers are not hardened and they should be used for no other purpose except that expressed.

Drive out the trigger hook axis bolt (OE-1217) and lift out the trigger hook (OE-1216) and its spring (OE-1343).

6. BREECH BLOCK, BOLT AND SEAR REMOVAL

Slide the breech block (OE-1304) and the breech bolt (OE-1315) out the rear of the breech casing. Remove the recoil sear axis bolt snap ring (OE-1346) with the special pliers in the tool roll. Drive out the recoil sear axis bolt (OE-1319) and lift out the sear (OE-1317) and its spring (OE-1341).

7. BREECH FACE PIECE REMOVAL

Insert breech face piece tool (367516-3) in the recess under the lip of the face piece securing spring (OE-1306) and bend the spring clear of the face piece. Turn the face piece 90 degrees, either way, with face piece spanner tool (OE-1619) and pull the face piece out.

8. STRIKER GEAR REMOVAL

Remove the hammer axis bolt (OE-1309) by turning it 180 degrees and pushing it out. The hammer (OE-1308) is free and can be lifted out. The striker pin (OE-1307) will then drop to the rear, out of the breech block.

9. BARREL ASSEMBLY REMOVAL

Rotate the barrel locking handle (OE-1049) into the position marked "Unlock." Rotate the barrel counter-clockwise, looking from the muzzle to the breech, until stopped by the stop pin (approximately 60 degrees) and pull out to the front.

NOTE—The clearances between the gun barrel and its housing in the breech casing have to be very small and consequently the barrel may feel tight. A special tool (300009-1) is provided for rotating the barrel. Asbestos gloves are provided for the handling of hot gun barrels.

10. STRIPPING THE GUN BARREL ASSEMBLY

Remove the retaining pin (OE-1212) using screwdriver (OE-1635) from the tool roll. The double loading stop plunger can then be taken out.

11. STRIPPING THE BARREL LOCKING AND DOUBLE LOADING STOP GEARS

Drive out the barrel locking handle pin (OE-1265) using punch (OE-1613). Drive out the barrel locking lever axis bolt (OE-1079) from the left to the right, using special punch in tool roll. This will free the barrel locking handle (OE-1049) for removal. Lift out the double loading stop (OE-1054), together with its two plungers (OE-1071) and two springs (OE-1336). Lift out the barrel locking lever

PARTIAL STRIPPING

Operation Number

(OE-1078). Lift out the barrel locking lever plunger (OE-1070) and its spring (OE-1339). Remove the double loading stop axis bolt securing spring (OE-1346) with special pliers in the tool roll. Tap out double loading stop axis bolt (OE-1063). Use special punch in tool roll and tap from left to right. Lift out double loading stop lever (OE-1053) and its plunger (OE-1069) and its spring (OE-1344). Bend down the upturned lug on the double loading stop guide bushing locking washer (OE-1081). Unscrew the double loading stop guide bushing (OE-1055) with (OE-1620) spanner in tool roll. This will carry the double loading stop plunger upper (OE-1080) along with it. Lift out the locking washer (OE-1081).

12. REMOVING THE BUFFER

Press in on the barrel spring seating ring retaining catch (OE-1058). Unscrew and remove the barrel spring seating ring (OE-1056) using (OE-1621) spanner.

NOTE—The barrel spring seating ring has a right hand thread. Pull the buffer (OE-1057) out to the front. Remove the twelve buffer springs (OE-1327).

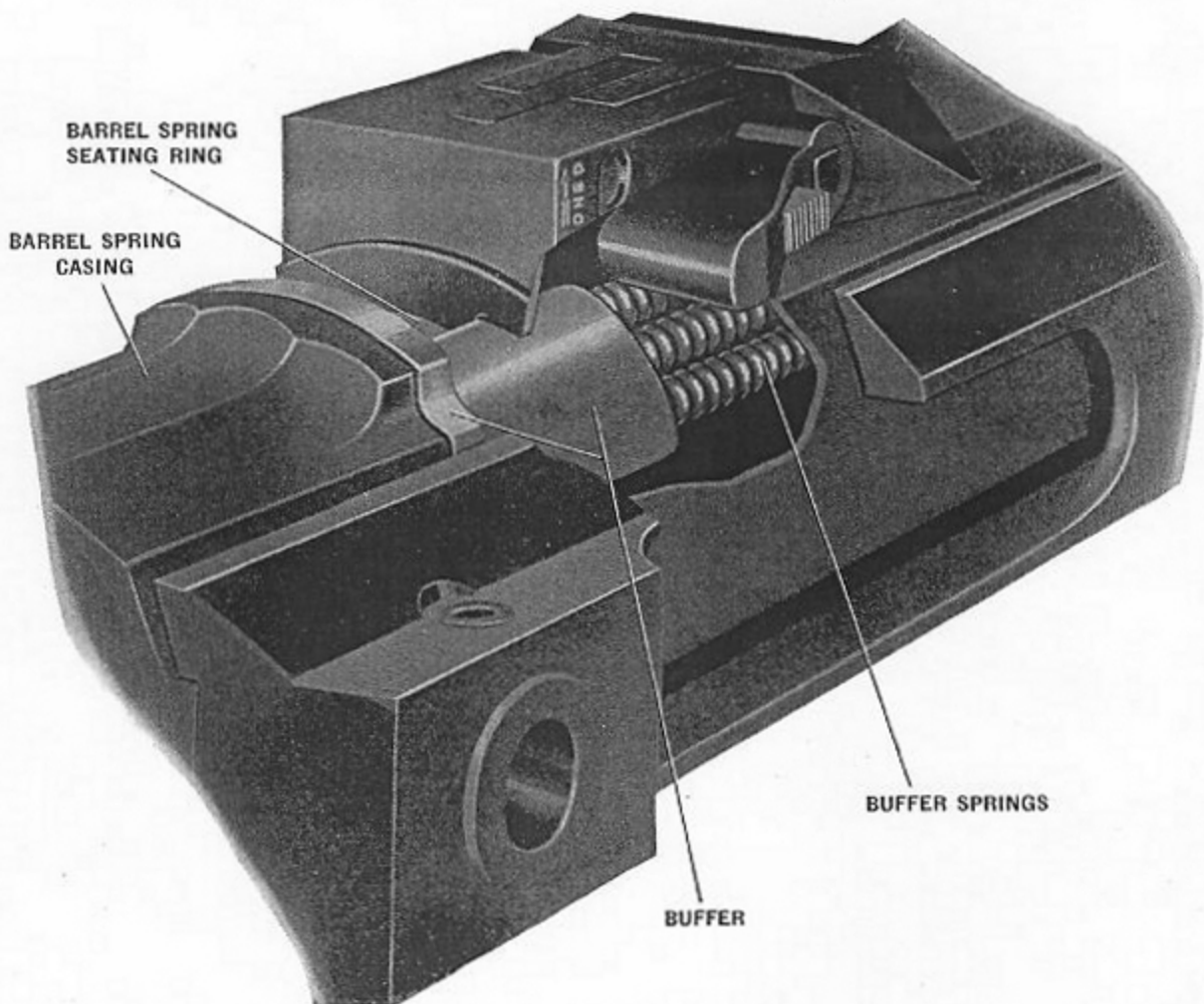

Figure 93—Recoil Buffer Springs

PARTIAL STRIPPING

Operation
Number

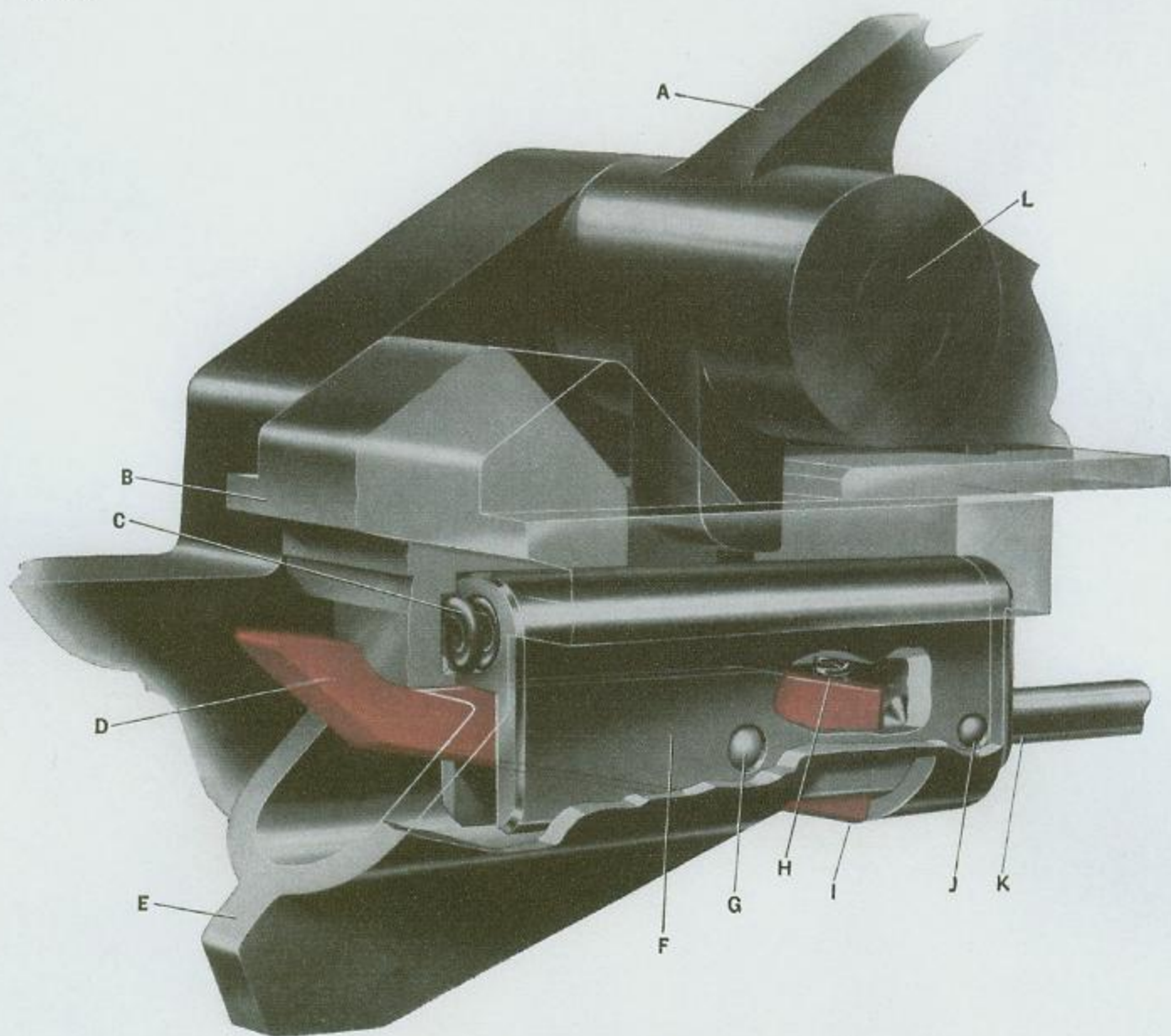

Figure 94—Magazine Interlock

A—Magazine catch lever (OE-1043)
B—Magazine securing lug on ejector
C—Interlock carrier spring (OE-1340)
D—Interlock lever (OE-1074)
E—Ejector (OE-1045)
F—Interlock carrier (OE-1066)
G—Axis bolt (OE-1067) holding interlock lever to interlock carrier

H—Magazine interlock lever spring (OE-1330)
I—Magazine interlock lever in catch recess in ejector
J—Axis pin (OE-1261) holding interlock rod to interlock carrier
K—Interlock rod (OE-1075)
L—Magazine catch lever spring axis bolt (OE-1076)

13. REMOVING THE EJECTOR AND MAGAZINE CATCH GEAR

Rotate the magazine catch lever (OE-1043) toward the muzzle so as to engage the catch. Press in the axis bolt securing spring (OE-1077) and drive out the axis bolt (OE-1035). Remove the magazine catch lever (OE-1043). Release the magazine interlock catch (OE-1046) by pressing down with

PARTIAL STRIPPING

Operation
Number

a suitable tool on the front ends of the catch. This releases the ejector (OE-1045). Slide out to the front the ejector (OE-1045) complete with the magazine interlock rod (OE-1075), interlock lever (OE-1074), interlock carrier (OE-1066), interlock lever spring (OE-1330), interlock carrier pin (OE-1261), interlock carrier axis bolt (OE-1067), interlock carrier spring (OE-1340).

NOTE—Two of the three springs (OE-1340) for the interlock catch and catch lever can be pulled out of the ejector for examination.

Remove the ejector from the interlock rod and carrier assembly by releasing the magazine interlock lever (OE-1074).

NOTE—The third spring (OE-1340) can then be pulled out of the carrier.

INSPECTION AND ADJUSTMENT AFTER PARTIAL STRIPPING

Operation Number

This completes partial stripping and next steps are:

1. Clean and oil the gun as instructed on page 108.
2. Inspect and adjust as follows:

The gun should be carefully examined, after partial stripping, for cracks in:

- | | |
|--|------------------|
| (a)—Buffer Springs | (d)—Hammer |
| (b)—Lip of the Breech Block Face Piece | (e)—Sear |
| (c)—Striker Pin | (f)—Trigger Hook |

Examine all springs. Replace any that are found weak, cracked, broken, bent, or distorted. Spares are supplied in the spare parts box for every spring.

Inspect all parts for burrs and remove with a fine file and smooth with a stone, if available.

STRIKER PIN PROTRUSION

There is a tendency for the striker pin to "set up" after long use. **See that the Striker Pin works freely in the Breech Block.**

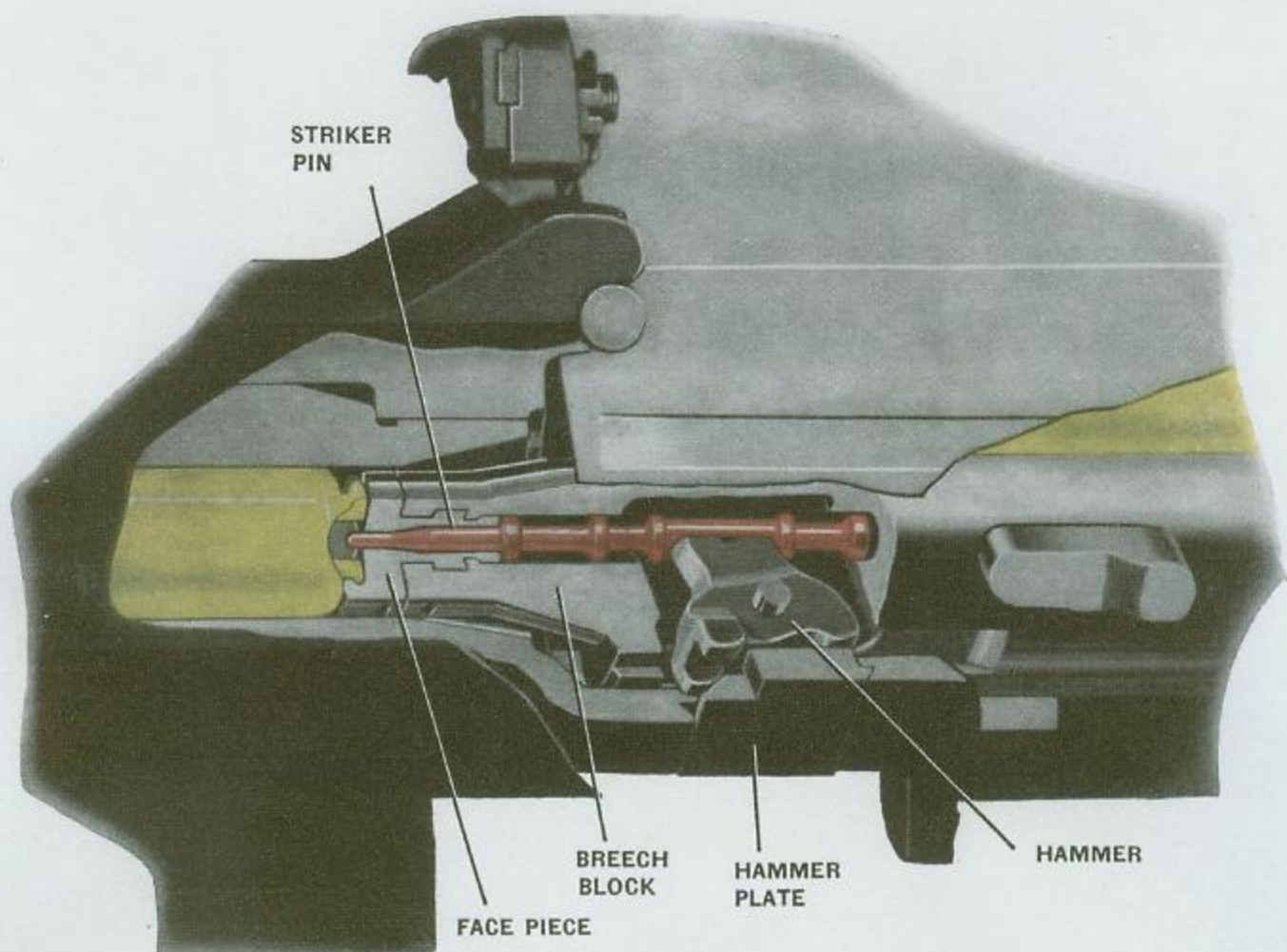

Figure 95—Examine Striker Pin After Extensive Use

REASSEMBLING A PARTIALLY STRIPPED GUN

The limits for protrusion, in service, are between 0.015 inch and 0.070 inch. This measurement is to be made with the striker pin pushed fully forward in the bolt.

NOTE—If the protrusion is too high, the point of the striker should be dressed back. If the protrusion is too low, there is no adjustment, and a spare striker pin should be installed.

CAUTION—Make certain that the striker pin hole in the breech block is free of burrs, dirt and corrosion.

Peening of the forward end of the striker pin hole in breech face piece (OE-1305) sometimes occurs and causes binding of the striker pin. When this happens, the face piece should be removed and the hole cleared out to its original size ("0992-"1004) using a No. 39 drill, or a new one installed.

HAMMER AND HAMMER PLATE WEAR

As previously stated, the striker pin reaches its full firing travel by momentum and not by a direct thrust all the way by the hammer, therefore, wear of the hammer and hammer plate is NOT important.

REASSEMBLING

Operation Number

1. MAGAZINE CATCH LEVER AND EJECTOR

Assemble the interlock rod (OE-1075) and the interlock lever (OE-1074) together with its spring (OE-1330), to the carrier (OE-1066). Insert one of the springs (OE-1340) into the interlock carrier. Slide the interlock carrier, complete with the interlock rod (as assembled above) into the ejector from the rear and push forward against the spring (OE-1340) until the carrier is held by the lever springing into the catch recess in the ejector. Insert the magazine interlock catch (OE-1046) into its recess in the breech casing. Insert the two remaining springs (OE-1340) and slide the ejector (as assembled above) into the breech casing from the front, **taking care that the rod passes through its guide block (OE-1073)**. Hook the front toe of the magazine catch lever (OE-1043) into its recess in the ejector. Pull the lever and the ejector bodily backwards against the springs until the rear toe of the lever can be hooked behind the catch (OE-1046) and thereby hold the ejector temporarily in position. Then insert the magazine catch lever axis assembly (OE-1035) through the lever.

2. BARREL LOCKING GEAR AND DOUBLE LOADING STOP GEAR

Install double loading stop guide bushing locking washer (OE-1081). Install double loading stop guide bushing (OE-1055) using (OE-1620) spanner in the tool roll. Install double loading stop plunger upper (OE-1080). Install double loading stop spring case (OE-1069) and its spring (OE-1344) for the double loading stop lever. Install barrel locking lever plunger (OE-1070) and its spring (OE-1339). Install double loading stop lever (OE-1053), install its axis bolt (OE-1063) tapping it from right to left, install its securing spring (OE-1346) using special pliers in the tool roll. Install barrel locking lever (OE-1078). Install double loading stop (OE-1054) together with its two plungers (OE-1071) and two springs (OE-1336).

When installing a new double loading stop (OE-1054) it should be checked for proper clearances. Check should be made before installing double loading stop lever (OE-1053), barrel locking lever (OE-1078), and axis bolt (OE-1063).

When double loading stop (OE-1054) is pressed down at the rear so that the vertical faces contact breech casing (OE-1040) at (B), Figure 96, the clearance at (A) should be ".001 to ".005. This can be checked by inserting feeler stock between the stop and breech casing as shown.

REASSEMBLING A PARTIALLY STRIPPED GUN

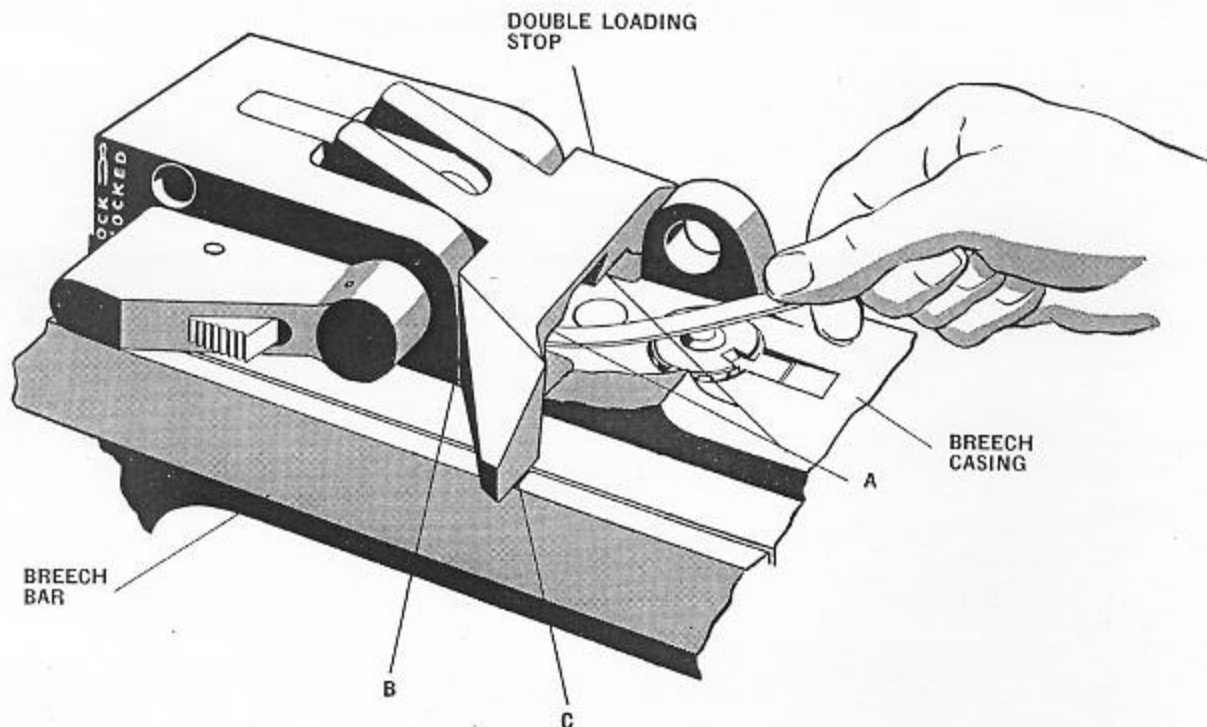

Figure 96—Checking Operation of Double Loading Stop (OE-1054)

Operation Number

If the clearance is greater than $^{\circ}005$, metal must be removed from the vertical stop faces of the **double loading stop** at (B). If the clearance is less than $^{\circ}001$, metal must be removed from the faces of the **double loading stop (OE-1054)** at (A).

When clearance at (A) is correct the horns of the double loading stop should clear the top edges of breech bars (OE-1310 and OE-1311) by $^{\circ}039$ to $^{\circ}059$ at (C).

If double loading stop fails to hold the breech bars due to a fluttering condition, clearance should be checked as described above. If the clearance between the lower edges of the horns of the double loading stop is less than $^{\circ}039$ or in excess of $^{\circ}059$ with the proper clearance of $^{\circ}001$ to $^{\circ}005$ between the stop and breech casing faces, it indicates a bent stop. In this case the stop (OE-1054) should be replaced with a new one.

NOTE—To accomplish this, first insert the two sets of springs and plungers into the stop. Face toward the muzzle and hold these in place with the first fingers of each hand. Then insert the stop without letting the plungers come out.

Install the barrel locking lever axis bolt (OE-1079), tapping it from right to left. Install the barrel locking handle (OE-1049). Install the barrel locking handle pin (OE-1265).

3. REASSEMBLING THE BUFFER

Install the twelve buffer springs (OE-1327) in the breech casing. Install the buffer (OE-1057) from the front. Screw in the barrel spring seating ring (OE-1056) using (OE-1621) spanner from tool roll.

REASSEMBLING A PARTIALLY STRIPPED GUN

Operation Number

Installing New Barrel Spring Seating Ring (OE-1056)

When installing a new barrel spring seating ring (OE-1056) it is necessary to grind a recess in the rear edge at the bottom for the seating ring retaining catch (OE-1058). Push up on catch (OE-1058) and screw the seating ring into place and tighten with spanner (OE-1621).

Mark location of retaining catch on seating ring with a scriber. Remove seating ring and grind the notch for retaining catch as marked. Reinstall the seating ring and tighten securely, using spanner (OE-1621).

NOTE—THE BARREL SPRING SEATING RING HAS A RIGHT HAND THREAD.

CAUTION—Hold the barrel spring seating ring retaining catch (OE-1058) inward while tightening this seating ring.

4. REASSEMBLING AND REPLACING THE BARREL

Lubricate double loading stop plunger lower (OE-1011) in Mark 4 barrel or (OE-1014) or (OE-1015 or OE-1016) in Mark 4 Mod. 1 barrel with extra light mineral oil, Navy Symbol 1042, 2110 or 2075 and insert it in the barrel. Lock this in place inserting the retaining pin (OE-1012) and tightening securely with the special screwdriver (OE-1635). Check to be certain the double loading stop plunger operates freely in the barrel. Place the barrel locking handle into the position marked "Unlock."

Insert the barrel with the "INSERT" arrow in line with the index mark on the front face of the barrel spring case. See Figure 97.

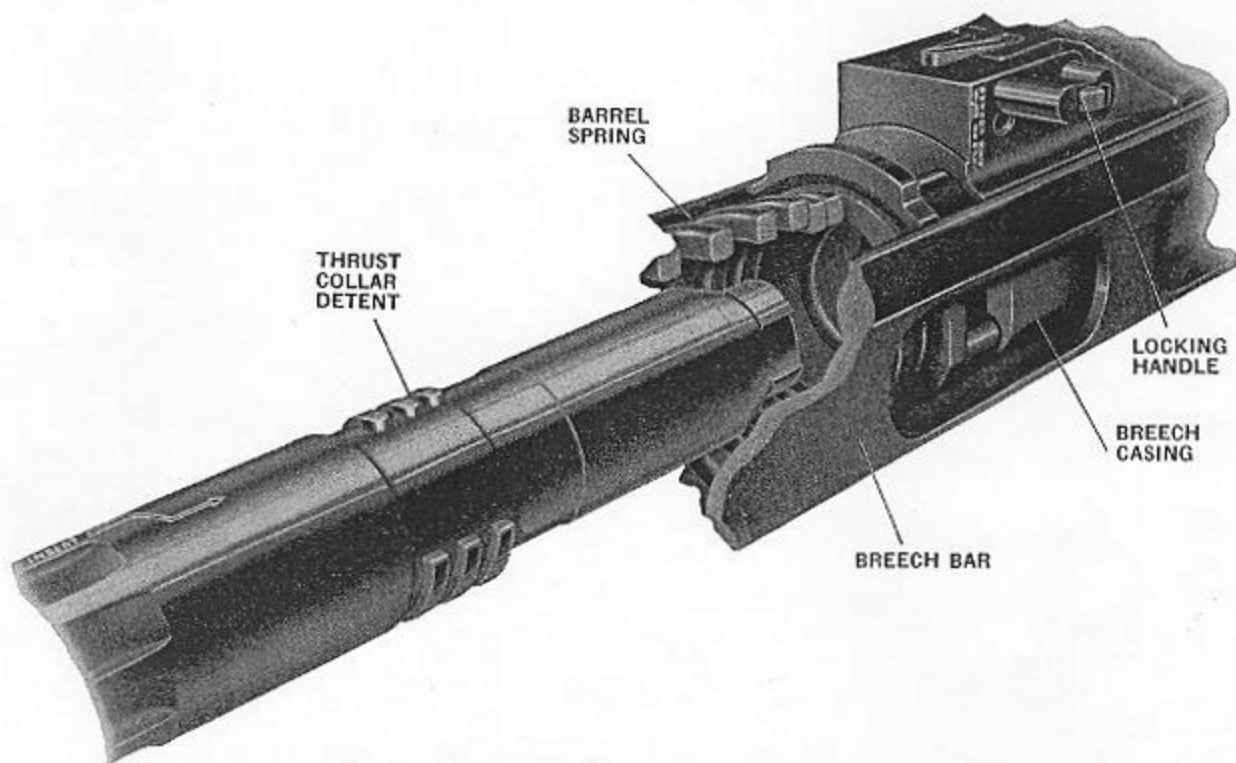

Figure 97—Barrel Installation

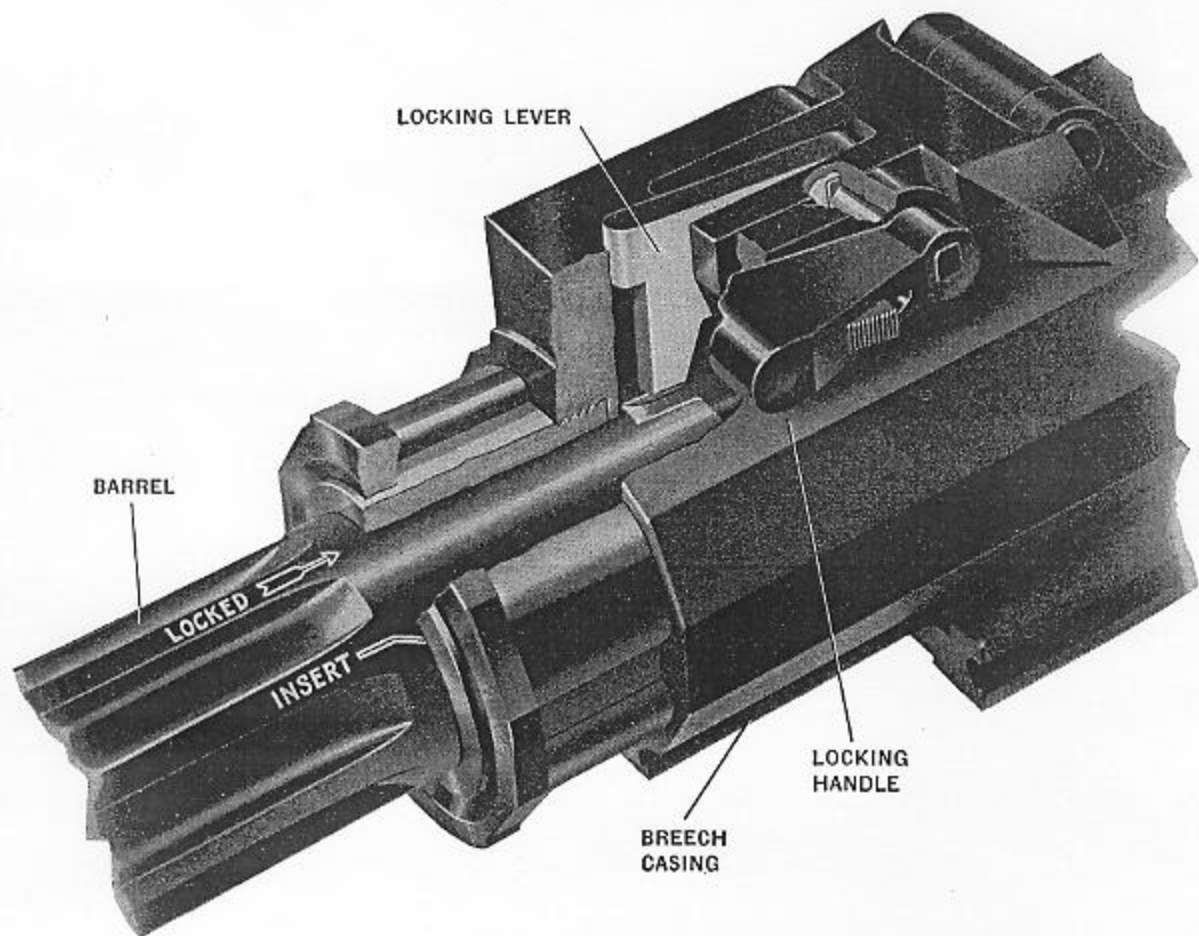

Figure 98—Gun Barrel Installed

Operation Number

When inserting the barrel, press down the horns of the double loading stop. This will prevent the double loading stop plunger in the breech casing from scoring the surface of the barrel.

NOTE—PUSH COMPLETELY IN.

Rotate the barrel clockwise, looking from the muzzle, until it is stopped by the barrel stop pin (approximately 60 degrees).

Place the barrel locking handle in the "LOCKED" position and then make certain that the barrel is locked against rotation by trying to turn it counterclockwise, looking from the muzzle.

5. STRIKER GEAR

Insert striker pin (OE-1307). Push it into the forward position and see that its slot is in line to receive the top portion of the hammer. Insert the hammer (OE-1308) into the slot in the striker pin. Insert the hammer axis bolt (OE-1309) in the hole in the hammer nearest the toes. Lock the axis bolt by rotating it 180 degrees so that it lies flush with the surface of the breech block.

REASSEMBLING A PARTIALLY STRIPPED GUN

Operation Number

6. BREECH BLOCK, BOLT AND SEAR

Place the sear spring (OE-1341) and sear (OE-1317) in position on the breech bolt and install the sear axis bolt (OE-1319). Install the sear axis bolt snap ring (OE-1346) using the pliers in tool roll. Install the breech bolt as assembled above in the breech block (OE-1304). Slide the two together into the breech casing and push into the forward position.

7. TRIGGER HOOK, CASING AND COVER PLATE

Place the trigger hook (OE-1216) and trigger hook spring (OE-1343), in position in the trigger hook holder (OE-1215). Install trigger hook axis bolt (OE-1217). Install the assembled trigger hook and holder from the rear into the trigger casing.

NOTE—A strong push is necessary when inserting the trigger hook into the trigger casing.

Install the trigger snap ring (OE-1238) using the special pliers in tool roll. Install the trigger buffer springs (OE-1326). Slide the trigger casing assembly (OE-1248) into the breech casing from the rear. Slide the trigger cover plate (OE-1233) on from the rear.

Care should be exercised when installing trigger snap ring (OE-1238), not to spread it too far. Casualties have resulted from failure of the snap ring during operation. This can often be attributed to weakening of the snap ring during removal or installation.

These pliers are not hardened and should be used for no other purpose except that expressed.

8. HAND GRIP REASSEMBLY

Screw on the hand grips. They should stop with the engraved number UP and with the hand grip catch engaged to prevent rotation.

NOTE—AT THIS POINT OF REASSEMBLY TEST THE OPERATION. Test the trigger gear, breech block and breech bolt for correct action by bringing the breech block and bolt, with the cotter (OE-1316) in place, to the rear and then pushing them forward again until they are held by the trigger gear. Trip the magazine interlock gear, press the trigger and see that the block and bolt are thereby fully released.

9. (a) BREECH BAR AND BARREL SPRINGS (Rectangular Wire)

Install the short barrel spring (OE-1320) to the rear. The **smaller diameter** end of the spring goes to the rear. Install the barrel spring center sleeve (OE-1325). Install the long barrel spring (OE-1321). Install the barrel spring front sleeve (OE-1318). **This sleeve is not used when the welded type barrel spring case (OE-1105) is used.** See Figure 99. Larger end of this sleeve goes toward the front. Slide the barrel spring case and left breech bar into place. While a helper is pushing backward on the spring case, slide front end of right breech bar over the barrel spring case trunnion and push the breech bolt cotter into the left breech bar. Insert the two cotter securing bolts (OE-1323) through the breech bars and cotter from the **top**. **If the split type retainers (OE-1324) are used, they should be assembled through the bolts from the bottom.** The two tongues of the retainers should be left athwart the gun. If left fore and aft, they will have a tendency to become disengaged on firing.

If the wire spring type retainers (299666-4) are used, they must be assembled from the top.

REASSEMBLING A PARTIALLY STRIPPED GUN

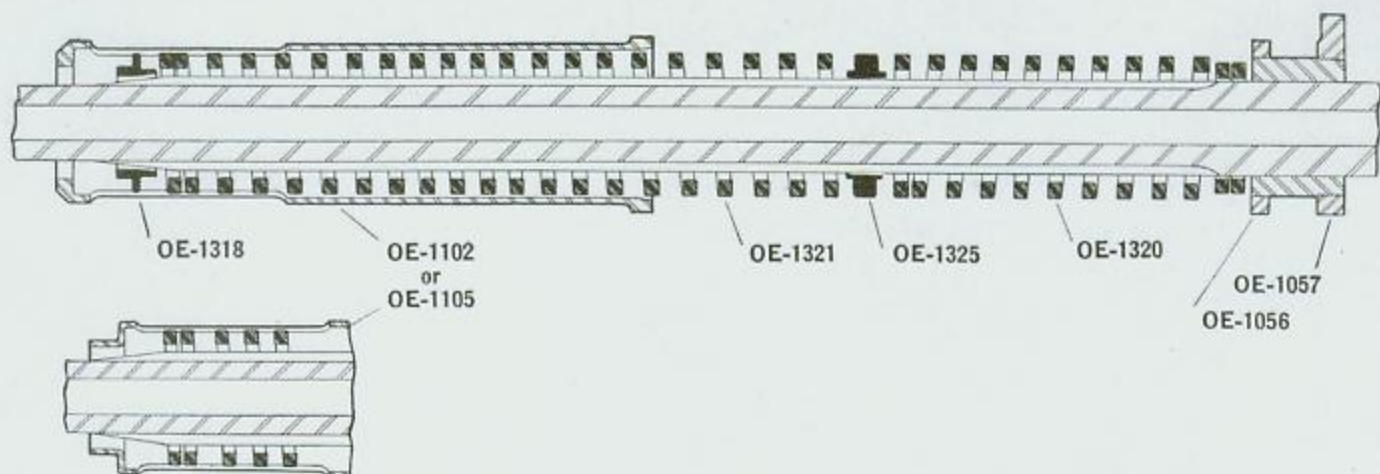

Figure 99—Installing Barrel Springs (Rectangular Wire Type)

Operation
Number

(b) BREECH BAR AND BARREL SPRING (Round Wire)

Place the rear barrel spring pilot (367534-3) on the gun barrel with its flat face to the rear. Place the long barrel spring (367533-1) over the gun barrel with the yellow painted end of the spring **forward**. Place the flat center spacer (367534-4) on the barrel. Place the short barrel spring (367533-2) on the gun barrel with its yellow painted end aft. If the barrel spring case is the forged type (OE-1102) place spring front sleeve (OE-1318) on the gun barrel with the large diameter end forward. Follow this with the spring case.

NOTE—Some guns use the welded type spring case (OE-1105), see Figure 100. In this case the front sleeve is not used.

Slide the barrel spring case and left breech bar into place. Slide front end of right breech bar over the barrel spring case trunnion while a helper is pushing backward on the spring case. Push the breech bolt cotter into the left breech bar. Assemble the breech bar securing bolts and retainers as instructed in Operation 9 (a).

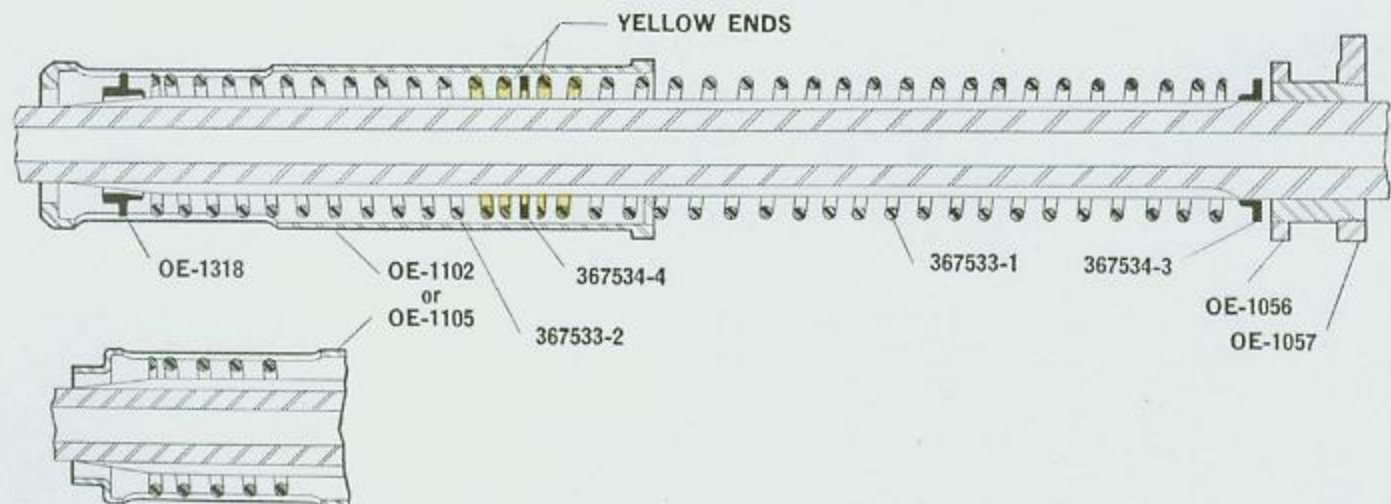

Figure 100—Installing Barrel Springs (Round Wire Type)

NOTES

GUN COMPLETE STRIPPING AND REASSEMBLY

Chapter 13

STRIPPING

The stripping operations listed under "Partial Stripping," pages 135 to 141, are sufficient for normal inspection and cleaning.

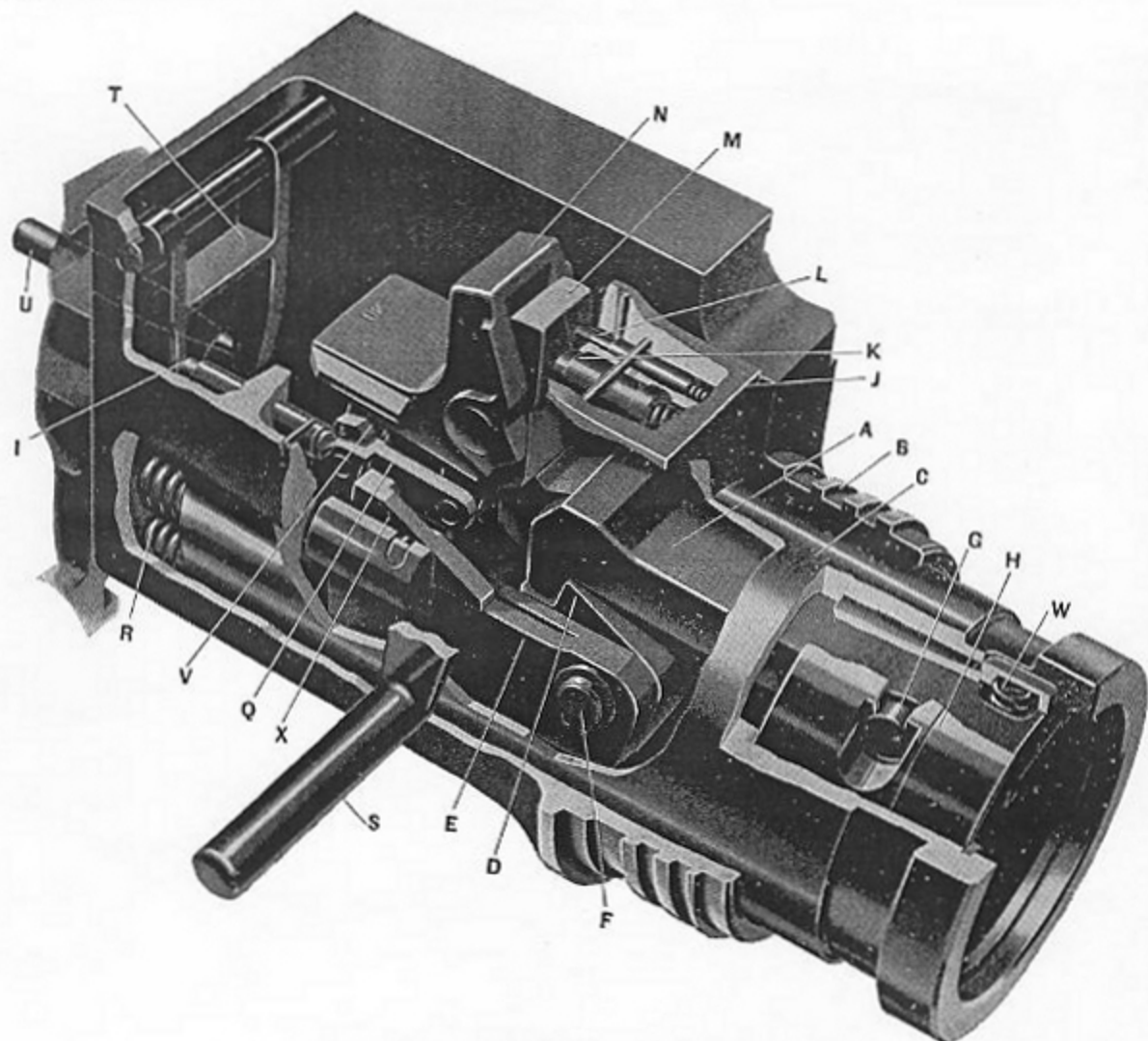

Figure 101—Trigger Mechanism

A—Trigger hook (OE-1216)
B—Breech casing (OE-1040)
C—Trigger casing (OE-1202)
D—Recoil sear (OE-1317)
E—Breech bolt (OE-1315)
F—Recoil sear axis bolt (OE-1319)
G—Trigger hook axis bolt (OE-1217)
H—Trigger hook holder (OE-1215)
I—Trigger pawl tripping plunger (OE-1225)
J—Parallelogram spring box (OE-1211)
K—Parallelogram lever plunger—rear (OE-1212)

L—Parallelogram lever plunger—top (OE-1213)
M—Parallelogram lever—rear (OE-1203)
N—Parallelogram lever—top (OE-1204)
Q—Parallelogram levers—bottom (OE-1206)
R—Trigger buffer springs (OE-1326)
S—Trigger (OE-1220)
T—Magazine interlock fork (OE-1230)
U—Magazine interlock rod (OE-1075)
V—Parallelogram lever—front (OE-1205)
W—Trigger hook spring (OE-1343)
X—Breech Pawl (OE-1104)

GUN COMPLETE STRIPPING

In case of damage to, or failure of, the smaller parts, further stripping may be necessary.

A number of these operations are independent of any other and care should be taken not to disassemble further than necessary, as for instance:

EXAMPLE—The barrel is not the first operation on the list for Partial Stripping, yet it may be removed normally without taking off any other part.

The complete stripping instructions given below are a continuation of the Partial Stripping given on pages 135 to 141.

Operation Number

1. TRIGGER CASING GEAR

Under Partial Stripping the following were removed: See page 137.

Trigger Cover Plate
Trigger Casing Complete
Trigger Buffer Spring
Trigger Hook and Holder

Drive out the parallelogram lever axis bolt—rear top (OE-1210) in either direction. Remove the trigger parallelogram complete. Remove the parallelogram spring box (OE-1211) by driving out its axis bolt (OE-1214) in either direction. A special punch is in the tool roll.

2. PARALLELOGRAM

Remove the two retaining pins (OE-1256) from the parallelogram lever axis bolt—bottom, front. Remove the spacing sleeve pin (OE-1272), and lever axis bolt, top front sleeve (OR-1208). Drive out the parallelogram lever axis bolt—top front (OE-1207). Drive out the parallelogram lever axis bolt—bottom front (OE-1209).

NOTE—Special punches are in the tool roll.

3. PARALLELOGRAM SPRING BOX

Drive out the two vertical pins (OE-1266) that are used to secure the two outer plungers (OE-1213). Remove the horizontal pin (OE-1268) that is used to secure the central plunger (OE-1212).

NOTE—There are two parallelogram lever plungers—top (OE-1213) and there is one parallelogram lever plunger—rear (OE-1212) that can be pulled out with their two springs (OE-1334) and one spring (OE-1342).

4. TRIGGER GEAR IN BREECH CASING

Drive out the trigger pin (OE-1265) in the hub of the trigger using special punch in tool roll. Tap out the trigger retaining bolt (OE-1221) inward using special punch in tool roll. Lift out the trigger (OE-1220). Tap out the trigger crank (OE-1223) inward using special punch in tool roll. Lift out the trigger pawl (OE-1222) and the pawl holder (OE-1219) together.

NOTE—The pawl can be separated from the pawl holder by driving out the pawl axis pin (OE-1231) from left to right.

Lift out the trigger intermediate lever (OE-1218).

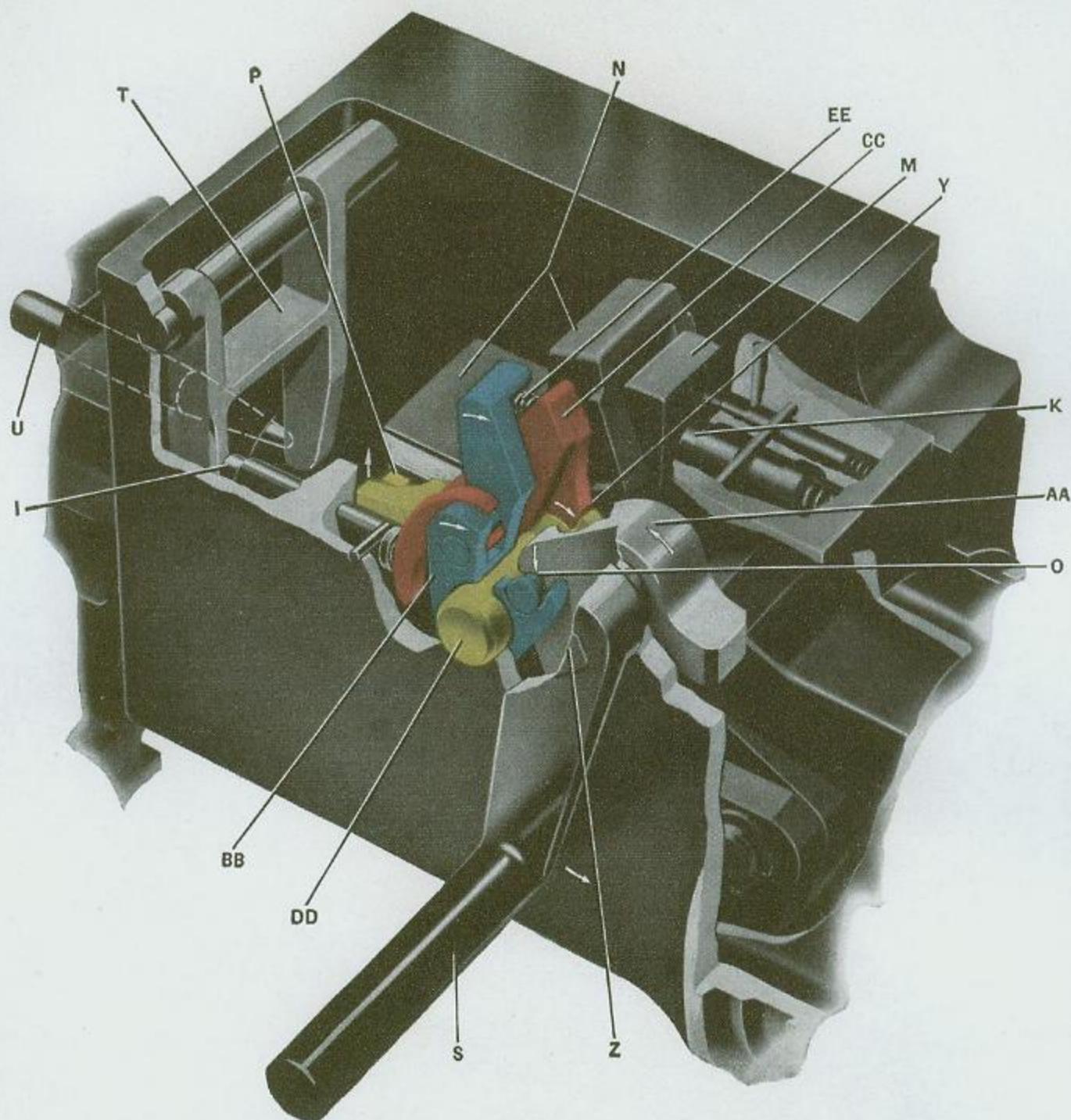

Figure 102—Trigger Action on Parallelogram

AA—Trigger intermediate lever (OE-1218)
 BB—Trigger pawl holder (OE-1219) shown in BLUE
 CC—Trigger pawl (OE-1222) shown in RED
 DD—Trigger crank (OE-1223) shown in YELLOW
 EE—Trigger pawl spring (OE-1332)
 M—Parallelogram rear lever
 N—Parallelogram top lever
 Q—Parallelogram bottom levers
 V—Parallelogram front lever

O—Point of contact between trigger intermediate lever and trigger pawl holder
 P—Point of contact between trigger crank toe and parallelogram top lever
 S—Trigger (OE-1220)
 T—Magazine interlock fork (OE-1230)
 U—Magazine interlock rod (OE-1075)
 Y—Point of contact between trigger pawl and trigger crank
 Z—Trigger retaining bolt (OE-1212)

GUN COMPLETE STRIPPING

Operation Number

5. SAFE/FIRE GEAR

Drive out, from left to right, the safety gear axis bolt pin (OE-1262). This pin secures the safe/fire lever (OE-1237) to the axis bolt (OE-1234). Drive out the safety gear axis bolt (OE-1234).

NOTE—This frees the Safe/Fire lever (OE-1237) and the safety cam (OE-1236).

6. MAGAZINE CATCH AND INTERLOCK GEAR

Follow operation 6, page 138 of "Partial Stripping" necessary for examination of the sear for fractures. Remove the magazine interlock lever (OE-1074) from the carrier by driving out its axis bolt (OE-1067).

NOTE—This also releases the magazine interlock lever spring (OE-1330).

Lift out the interlock catch (OE-1046). Remove the magazine interlock fork (OE-1230) by driving out its axis bolt (OE-1224) in either direction.

7. TRIGGER PAWL TRIPPING BOLT

Drive out the trigger pawl tripping bolt spring case retaining pin (OE-1263). This pin secures the spring case (OE-1226) to the breech casing. Remove the spring case (OE-1226) complete with the trigger pawl tripping bolt (OE-1225) and its spring (OE-1338). The trigger pawl tripping bolt and its spring can then be removed from the spring case by driving out the trigger pawl tripping bolt retaining pin (OE-1255) transversely through the spring case.

8. MAGAZINE INTERLOCK ROD GUIDE BLOCK

Drive out the interlock rod guide block retaining pin (OE-1267) and press the block (OE-1073) out from the breech casing (OE-1040).

9. BREECH PAWLS

Remove the breech pawls (OE-1103 Right and OE-1104 Left) by prying out the right and left axis pins (OE-1322). The breech pawls and their springs (OE-1329) will then fall out.

10. HAMMER PLATE

Lift the end of the hammer plate securing spring (OE-1064) clear of the hammer plate (OE-1060) and tap the hammer plate upward to remove.

11. HAND GRIPS RETAINING CATCH

Drive out the retaining catch axis bolt (OE-1068) and lift out the retaining catch (OE-1062). Drive out the retaining catch plunger pin (OE-1258) and remove its spring (OE-1335) and the retaining catch plunger (OE-1065).

12. BARREL SPRING SEATING RING RETAINING CATCH

Drive out in either direction the barrel spring seating ring retaining catch retaining pin (OE-1269). Lift out the retaining catch (OE-1058) and its spring (OE-1337).

GUN COMPLETE STRIPPING

Operation
Number

13. BREECH CASING BARREL STOP PIN

Press in the breech casing barrel stop pin plate pin (OE-1072) using a pointed tool from tool roll. Drive out, in either direction, the barrel stop pin plate (OE-1059). Lift out the barrel stop pin (OE-1052), the barrel stop pin plate pin (OE-1072) and the barrel stop pin plate spring (OE-1331).

14. TRIGGER INTERMEDIATE LEVER PLUNGER ASSEMBLY

Push the trigger intermediate lever spring case (OE-1227) out by pushing on its rear end at the rear face of the breech casing. Remove the trigger intermediate lever spring case distance piece (OE-1228). Drive out the trigger intermediate lever plunger retaining pin (OE-1257). Lift out the trigger intermediate lever plunger (OE-1229) and its spring (OE-1333).

GUN COMPLETE REASSEMBLY

The complete reassembly instructions given below are a continuation of the "Reassembling a Partially Stripped Gun" on Pages 143 to 148.

Operation Number

1. TRIGGER INTERMEDIATE LEVER PLUNGER

Place the trigger intermediate lever plunger (OE-1229) and its spring (OE-1333) in the trigger intermediate lever spring case (OE-1227). Install the trigger intermediate lever plunger retaining pin (OE-1257). Install the trigger intermediate lever spring case distance piece (OE-1228). Push the rear end of the trigger intermediate lever spring case (OE-1227) into the rear face of the breech casing.

2. BARREL STOP PIN IN THE BREECH CASING

Install the barrel stop pin plate spring (OE-1331), the barrel stop pin plate pin (OE-1072) and the barrel stop pin (OE-1052). Drive in, from either direction, the barrel stop pin plate (OE-1059).

3. BARREL SPRING SEATING RING RETAINING CATCH

Install in the breech casing the retaining catch (OE-1058) and its spring (OE-1337). Drive in, from either direction, the barrel spring seating ring retaining catch retaining pin (OE-1269).

4. HAND GRIPS RETAINING CATCH

Install in the retaining catch (OE-1062) the retaining catch plunger (OE-1065), its spring (OE-1335) and drive in the retaining catch plunger pin (OE-1258). Install the retaining catch (OE-1062) in the breech casing and drive in the retaining catch axis bolt (OE-1068).

5. HAMMER PLATE

Tap the hammer plate (OE-1060) downward into its recess in the breech casing. Make certain the hammer plate securing spring is in place.

6. BREECH PAWLS

Install the breech pawl springs (OE-1329) in the breech casing. Install the right breech pawl (OE-1103) and left breech pawl (OE-1104) on their springs, installed above. Install the breech pawl axis pins (OE-1322).

7. MAGAZINE INTERLOCK ROD GUIDE BLOCK

Press the magazine interlock rod guide block (OE-1073) in place in the breech casing (OE-1040) and drive in the interlock rod guide block retaining pin (OE-1267).

8. TRIGGER PAWL TRIPPING BOLT

Install the trigger pawl tripping bolt spring and the bolt in place in the trigger pawl tripping bolt spring case (OE-1226). Drive the trigger pawl tripping bolt retaining pin (OE-1255) transversely through the spring case. Place the spring case (as just assembled) and the trigger pawl tripping bolt spring (OE-1338) and tripping bolt (OE-1225) in the breech casing. Drive in the trigger pawl tripping bolt spring case retaining pin (OE-1263). This pin secures the spring case to the breech casing.

9. MAGAZINE INTERLOCK FORK

Reassemble the magazine interlock fork (OE-1230) to the breech casing by inserting the fork in its position and drive in its axis bolt (OE-1224) from either direction.

GUN COMPLETE REASSEMBLY

Operation Number

10. SAFE/FIRE GEAR

Install the safe/fire lever (OE-1237) and the safety cam (OE-1236) and drive in the axis bolt (OE-1234). Install the safe/fire lever (OE-1237) on its axis bolt and drive the axis bolt pin (OE-1262) in from right to left. This pin secures the safe/fire lever (OE-1237) to the axis bolt (OE-1234).

11. TRIGGER PAWL, PAWL HOLDER, TRIGGER CRANK

Assemble the trigger pawl (OE-1222) and its spring (OE-1332) to the pawl holder (OE-1219) by inserting the pawl axis pin (OE-1231) from right to left. Drop this trigger pawl and holder assembly (OE-1246) into its position in the breech casing. Insert the trigger crank (OE-1223) from inside of the breech casing.

NOTE—The pawl, pawl holder, and trigger crank are all stamped with the letter “L” and when correctly assembled, all three letters must be visible from above. IF NOT VISIBLE, THE ASSEMBLING HAS BEEN INCORRECTLY DONE.

12. TRIGGER INTERMEDIATE LEVER

Insert the trigger intermediate lever (OE-1218) so as to engage the pin on the pawl holder.

13. TRIGGER AND TRIGGER HOOK

Reassemble the trigger (OE-1220) and trigger retaining bolt (OE-1221) from inside the breech casing. Install the trigger pin (OE-1265). Reassemble the trigger hook (OE-1216) and its spring (OE-1343) in the trigger holder (OE-1215) and drive in the trigger hook axis bolt (OE-1217).

14. PARALLELOGRAM

Place the two outer plungers [parallelogram lever plunger—top, (OE-1213)] and place the central plunger [parallelogram lever plunger—rear, (OE-1212)] and their three springs (2 of OE-1334 for OE-1213) and (1 of OE-1342 for OE-1212) in the parallelogram spring box (OE-1211). Install the horizontal pin (OE-1268) that is used to secure the central plunger (OE-1212). Install the two vertical pins (OE-1266) that are used to secure the two outer plungers (OE-1213). Reassemble the parallelogram. Install the parallelogram lever axis bolt, bottom front (OE-1209). Install the parallelogram lever axis bolt, top front (OE-1207)*. Install the parallelogram lever axis bolt, top front sleeve (OE-1208)* and the sleeve pin (OE-1272)*. Install the two retaining pins (OE-1256) on the lever axis bolt, bottom front.

NOTE—The parallelogram levers are all marked “L” and “R.” A correctly assembled parallelogram will have all of the letters “L” visible and on the left side, and all of the letters “R” visible and on the right side. The parallelogram top lever is marked with the word “UP” and this must be visible from above.

Install the parallelogram spring box assembled above and drive in its axis bolt (OE-1214). Drive from either direction. Place the parallelogram assembled above in the trigger casing pushing it rearward against the spring plungers in the spring box in order to get the holes in line for the lever axis bolt rear top (OE-1210). A strong push is required. Drive this lever axis bolt (OE-1210) in from either direction.

*In later production a new parallelogram assembly (OE-1200) is used in place of the original assembly (OE-1240). This change involves the use of a new style parallelogram lever axis bolt—top (OE-1201) in place of axis bolt—top front (OE-1207) and bolt sleeve (OE-1208).

GUN COMPLETE REASSEMBLY

Operation Number

When servicing the earlier type parallelogram assembly, and bolt (OE-1207) and sleeve (OE-1208) are found to be in need of replacement, the new type bolt (OE-1201) alone can be used. The head of the bolt **MUST** be installed on the right side.

15. TRIGGER HOOK HOLDER AND BUFFER SPRING

Install the trigger hook holder assembled in Operation 13, into the rear of trigger casing. A strong push is required. Replace the trigger snap ring (OE-1238) that secures the trigger hook holder in the trigger casing, using the special pliers in the tool roll. Replace the trigger buffer springs (OE-1326).

16. Complete the reassembly by following the instructions for reassembly, operations 1 through 9 inclusive, given in detail on "Reassembling a Partially Stripped Gun," Pages 143 to 148.

NOTES

NOTES

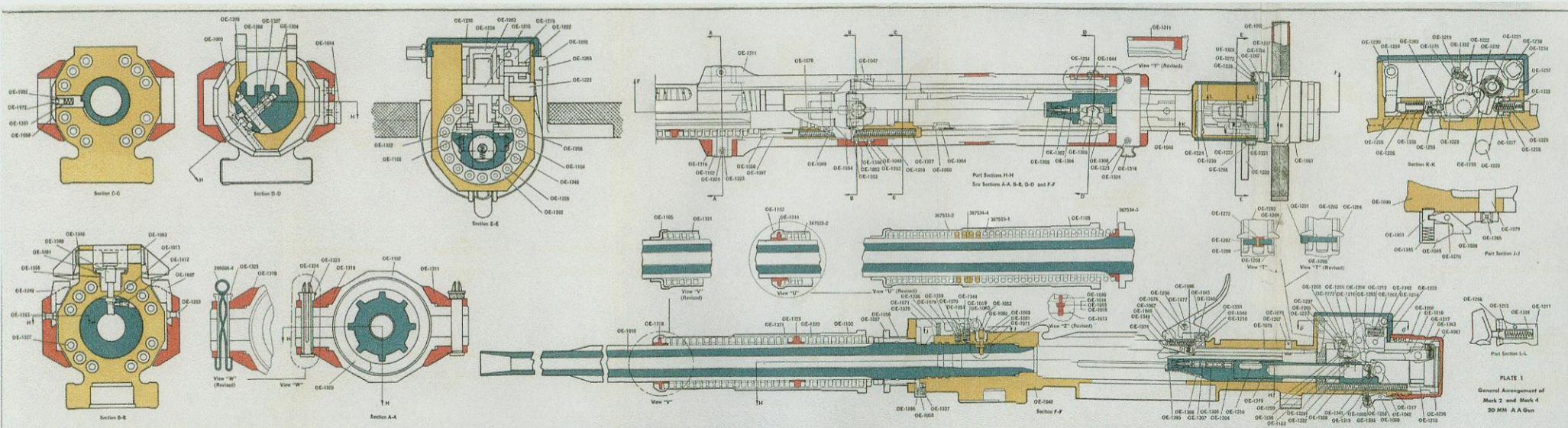
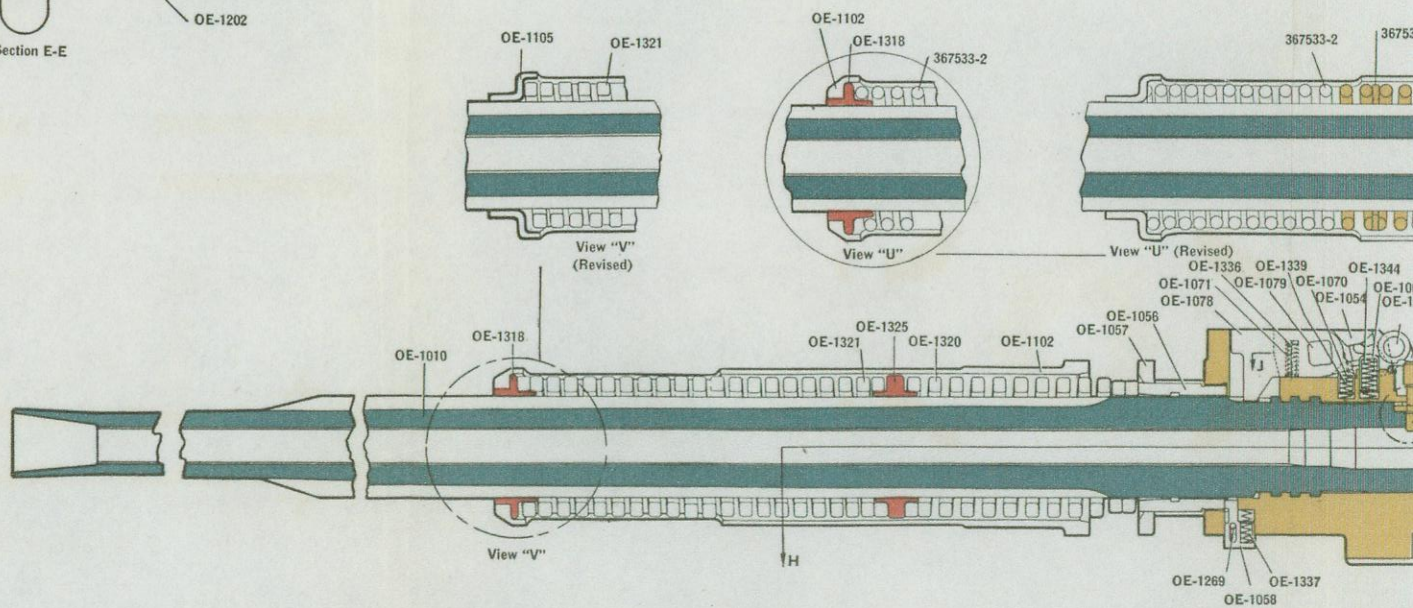
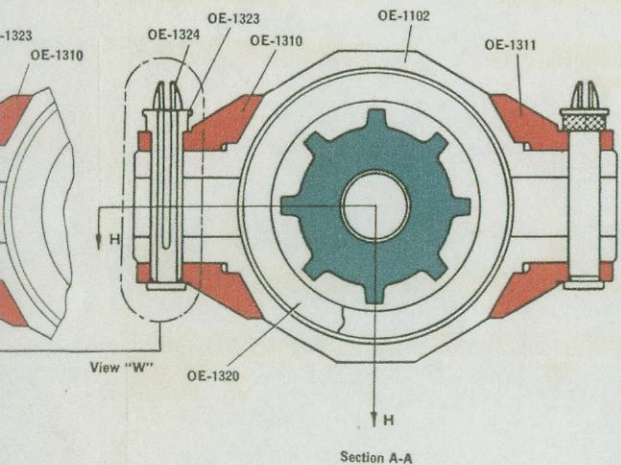
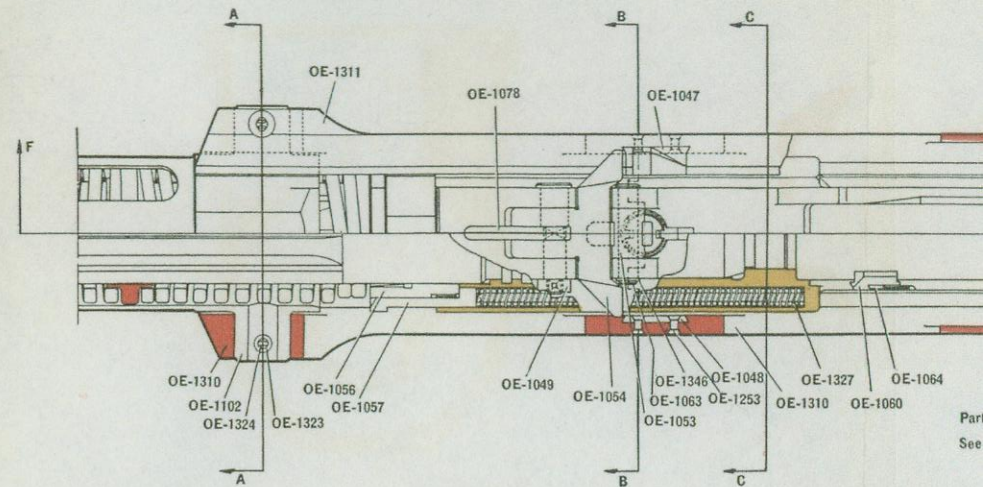
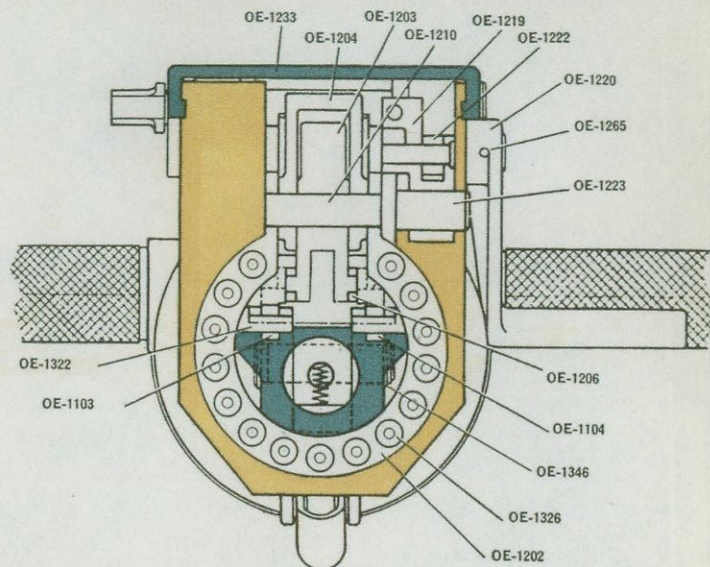
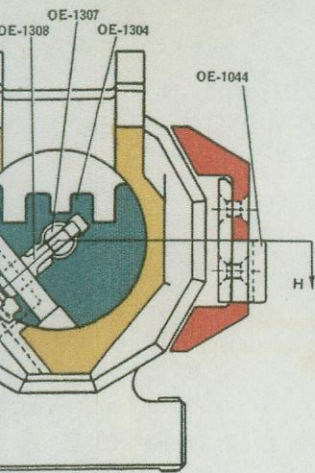
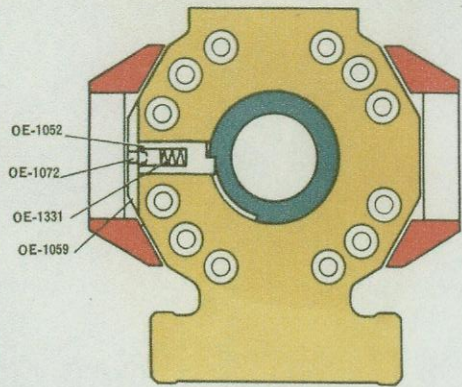
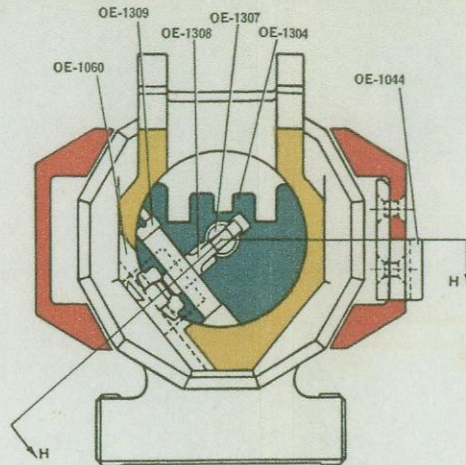

PLATE 1
 General Arrangement of
 Mark 2 and Mark 4
 30 MM A Gun





Section C-C



Section D-D

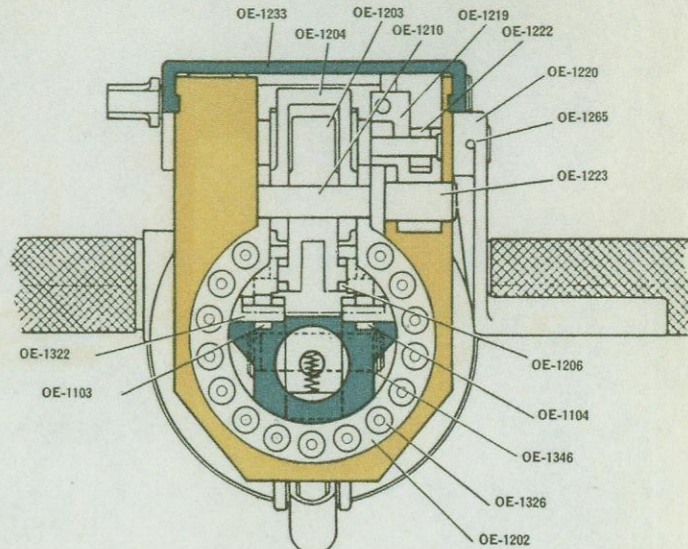

Section E-E

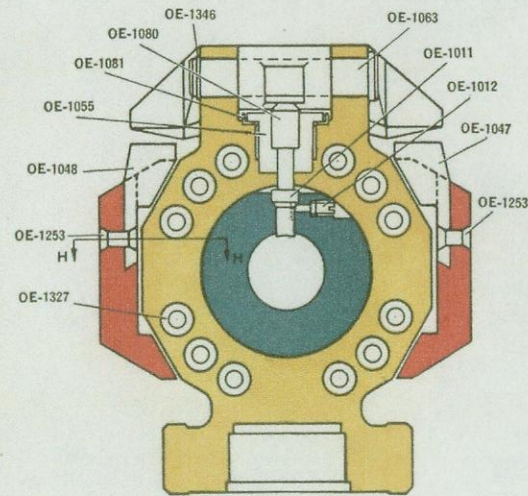
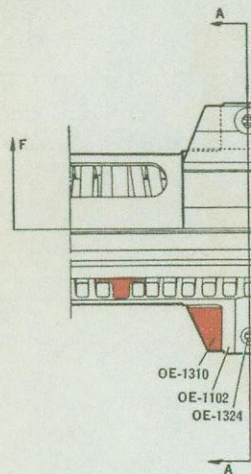

Section B-B

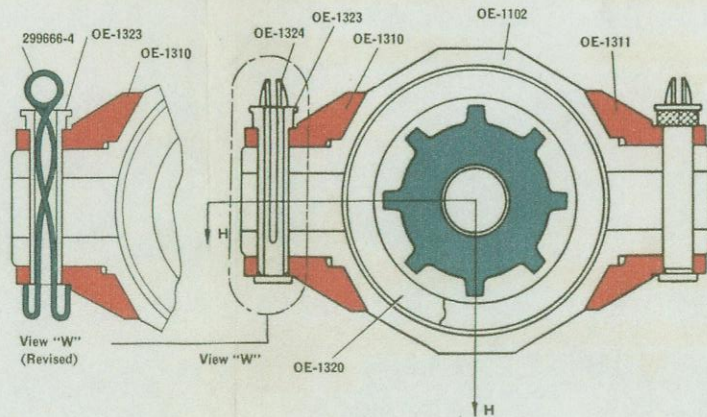

Section A-A

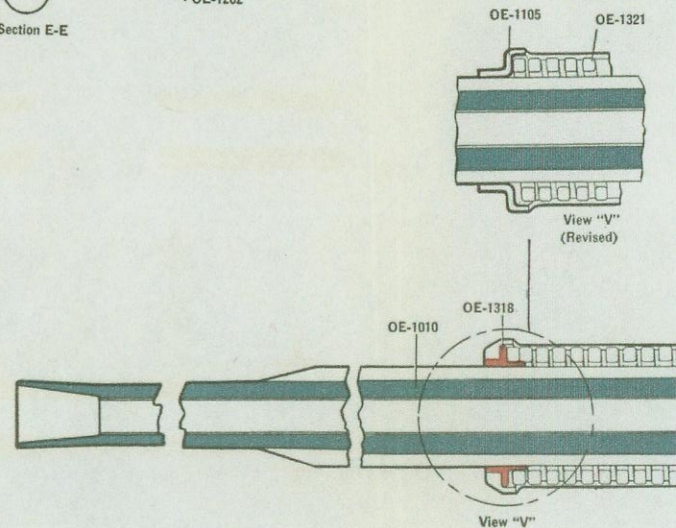

INSTRUCTIONS FOR ORDERING REPLACEMENT PARTS

Plate 1 is for reference purposes only and should not be used directly for ordering parts. When a part has been identified on the plate, reference should be made to the OE to Bureau of Ordnance Numbers Cross Index at the back of this pamphlet for the Parts List page on which this part may be found. If no page reference is indicated, then the part is not supplied individually and the sub assembly or assembly of which it is a component should be ordered.

PARTS LIST

20-MM ANTI-AIRCRAFT GUNS

MARK 4 AND MARK 2







Part numbers of the Mark 4 parts are shown in the Mark 4 (OE. or part number) column. Part numbers of the Mark 2 parts are shown in the Mark 2 (item) column.

Parts that are interchangeable between Mark 4 and Mark 2 have their Mark 4 (OE. or part number) and Mark 2 (item) number on the same line.





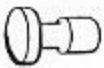



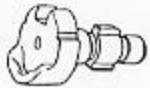

Parts of an assembly have their names indented under the assembly name.

Where parts have been redesigned and are interchangeable, only the new parts are listed.











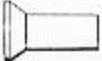

BARREL

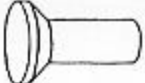
MK. 4 OE. NO.	MK. 2 ITEM NO.	NO. PCS.	COMPONENT	SKETCH
1001	1	2	Barrel Assembly (Spare with Gun)—Consists of:	
1010	1	1	Barrel	
1011	2	1	Double Loading Stop Plunger—Lower	
1012	4	1	Retaining Pin for OE-1011	
1003		2	Barrel Assembly—Mod. 1 (Spare with Gun)—Consists of:	
1013		1	Barrel—Mod. 1	
1014 1015 1016		1	Double Loading Stop Plunger—Lower (Use OE-1014 for replacement of OE-1015 and OE-1016)	
1012	4	1	Retaining Pin for OE-1014	













GUN MECHANISM

MK. 4 DE. NO.	MK. 2 ITEM NO.	NO. PCS.	COMPONENT	SKETCH
1301	10 Assy.	1	Breech Block Assembly - Consists of:	
1303	10-12	1	Breech Block and Spring Assembly - Consists of:	
1304	10	1	Breech Block	
1306	12	1	Securing Spring for OE-1305	
1305	11	1	Breech Face Piece	
1307	13	1	Breech Block Striker Pin	
1308	14	1	Hammer	
1309	15	1	Axis Bolt for OE-1308	
1312	17 Assy.	1	Breech Bar Assembly - Left - Consists of:	
1310	17	1	Breech Bar - Left	
1048	601	1	Double Loading Stop Plate - Left	
1253	48	2	Double Loading Stop Plate to Breech Bar Rivet	
1313	16 Assy.	1	Breech Bar Assembly - Right - Consists of:	











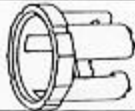

GUN MECHANISM

MK. 4 OE. NO.	MK. 2 ITEM NO.	NO. PCS.	COMPONENT	SKETCH
1311	16	1	Breech Bar - Right	
1047	600	1	Double Loading Stop Plate - Right	
1253	48	2	Double Loading Stop Plate to Breech Bar Rivet	
1044	38	1	Hand Cocking Catch Plate	
1254	49	4	Hand Cocking Catch Plate to Breech Bar Rivet	
1315	20	1	Breech Bolt	
1316	21	1	Breech Bolt Cotter	
1317	22	1	Recoil Sear	
1341	23	1	Recoil Sear Spring	
1319	25	1	Recoil Sear Axis Bolt	
1346	44	1	Snap Ring for OE-1319	
1103	35	1	Breech Pawl - Right	
1104	36	1	Breech Pawl - Left	





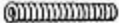



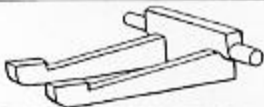
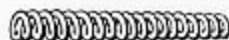

GUN MECHANISM

MK. 4 PART NO.	MK. 2 ITEM NO.	NO. PCS.	COMPONENT	SKETCH
OE-1329	37	2	Breech Pawl Spring	
OE-1322	30	2	Axis Bolt for OE-1103 and OE-1104	
OE-1102	18	1	Barrel Spring Case	
OE-1318	24	1	Barrel Spring Sleeve—Front (Used with OE-1102 only)	
OE-1105	24	1	Barrel Spring Case (2nd type)	
OE-1320	26-R	1	Barrel Spring—Rear (Superseded by 367534-1, see page 177)	
OE-1321	26-L	1	Barrel Spring—Front (Superseded by 367534-2, see page 177)	
OE-1325	43	1	Barrel Spring Sleeve—Center	
OE-1323	32	4	Breech Bar Securing Bolt	
299666-4	34	4	Retainer for OE-1323 (Supersedes OE-1324)	
OE-1324	34	4	Securing Spring Pin for OE-1323 (Superseded by 299666-4)	
OE-1040	57	1	Breech Casing	
OE-1056		1	Barrel Spring Seating Ring	





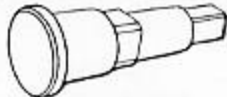







GUN MECHANISM

MK. 4 PART NO.	MK. 2 ITEM NO.	NO. PCS.	COMPONENT	SKETCH
	618	1	Barrel Spring Seating Ring	
OE-1058	620	1	Barrel Spring Seating Ring Retaining Catch	
OE-1269	625	1	Retaining Pin for OE-1058	
OE-1337	609	1	Spring for OE-1058	
OE-1057	619	1	Buffer	
OE-1327	621	12	Buffer Spring <small>(Superseded by 299676-7, see page 177)</small>	
OE-1073	58	1	Magazine Interlock Rod Guide Block	
OE-1267	116	1	Retaining Pin for OE-1073	
OE-1045	59	1	Ejector	
OE-1074	60	1	Magazine Interlock Lever	
OE-1330	105	1	Spring for OE-1074	
OE-1066	103	1	Magazine Interlock Carrier	
OE-1261	115	1	Magazine Interlock Carrier Pin	











GUN MECHANISM

MK. 4 OE. NO.	MK. 2 ITEM NO.	NO. PCS.	COMPONENT	SKETCH
1067	108	1	Axis Bolt for OE-1066	
1340	62	1	Spring for OE-1066	
1075	61	1	Magazine Interlock Rod	
1046	63	1	Magazine Interlock Catch	
1340	62	2	Spring for OE-1046	
1043	66	1	Magazine Catch Lever	
1035	64 Assy.	1	Magazine Catch Lever Axis Assembly—Consists of:	
1076	64	1	Axis Bolt for OE-1043	
1077	65	1	Axis Bolt Securing Spring	
1250	124	2	Rivet for OE-1077	
1078	67	1	Barrel Locking Lever	
1079	68	1	Axis Bolt for OE-1078	
1070	611	1	Barrel Locking Lever Plunger	

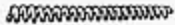



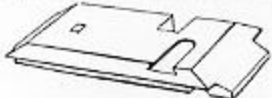



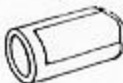

GUN MECHANISM

MK. 4 OE. NO.	MK. 2 ITEM NO.	NO. PCS.	COMPONENT	SKETCH
1339	615	1	Spring for OE-1070	
1039		1	Barrel Locking Handle Assembly—Consists of:	
1049	602	1	Barrel Locking Handle	
1265	622	1	Barrel Locking Handle Pin—Small	
1050	603	1	Barrel Locking Handle Retaining Catch	
1270	623	1	Axis Pin for OE-1050	
1051	604	1	Barrel Locking Handle Locking Plunger	
1345	605	1	Spring for OE-1051	
1052	606	1	Breech Casing Barrel Stop Pin	
1059	632	1	Breech Casing Barrel Stop Pin Plate	
1072	630	1	Pin for OE-1059	
1331	631	1	Spring for OE-1059	
1080	617	1	Double Loading Stop Plunger—Upper	

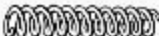









GUN MECHANISM

MK. 4 OE. NO.	MK. 2 ITEM NO.	NO. PCS.	COMPONENT	SKETCH
1053	607	1	Double Loading Stop Lever	
1063	97	1	Axis Bolt for OE-1053	
1346	629	1	Securing Spring for OE-1063	
1054	608	1	Double Loading Stop	
1071	612	2	Double Loading Stop Plunger	
1336	613	2	Spring for OE-1071	
1069	610	1	Double Loading Stop Plunger	
1344	614	1	Spring for OE-1069	
1055	616	1	Double Loading Stop Guide Bushing	
1081	633	1	Locking Washer for OE-1055	
1033	82-101	1	Hammer Plate and Spring Assembly—Consists of:	
1060	82	1	Hammer Plate	
1064	101	1	Hammer Plate Securing Spring	













GUN MECHANISM

MK. 4 OE. NO.	MK. 2 ITEM NO.	NO. PCS.	COMPONENT	SKETCH
1036	85 Assy.	1	Hand Grips Assembly	
1038	86 Assy.	1	Hand Grips Retaining Catch Assembly—Consists of:	
1062	86	1	Hand Grips Retaining Catch	
1065	102	1	Hand Grips Retaining Catch Plunger	
1258	111	1	Pin for OE-1065	
1335	106	1	Spring for OE-1065	
1068	109	1	Axis Bolt for OE-1062	
1279	126 Assy.	1	Trigger Casing Assembly—Consists of:	
1202	126	1	Trigger Casing	
1238	184	1	Trigger Snap Ring	
1245	141 Assy.	1	Trigger Hook and Holder Assembly—Consists of:	
1215	141	1	Trigger Holder Hook	
1216	142	1	Trigger Hook	









GUN MECHANISM

MK. 4 OE. NO.	MK. 2 ITEM NO.	NO. PCS.	COMPONENT	SKETCH
1217	144	1	Axis Bolt for OE-1216	
1343	143	1	Spring for OE-1216	
1200	127 Assy.	1	Parallelogram Assembly—Consists of:	
1203	127	1	Parallelogram Lever—Rear	
1204	128	1	Parallelogram Lever—Top	
1205	129	1	Parallelogram Lever—Front	
1206	130	2	Parallelogram Lever—Bottom	
1201	131	1	Parallelogram Lever Axis Bolt—Top <small>(Supersedes OE-1207, 1208, and 1272, see page 177)</small>	
1256	177	2	Retaining Pin for OE-1209	
1209	133	1	Parallelogram Lever Axis Bolt—Bottom Front	
1210	134	1	Parallelogram Lever Axis Bolt—Rear Top	
1247	135 Assy.	1	Spring Box Assembly—Consists of:	
1211	135	1	Parallelogram Spring Box	

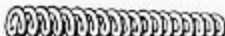

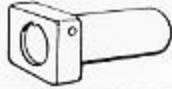
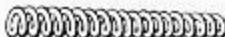







GUN MECHANISM

MK. 4 OE. NO.	MK. 2 ITEM NO.	NO. PCS.	COMPONENT	SKETCH
1212	136	1	Parallelogram Lever Plunger-Rear	
1342	138	1	Spring for OE-1212	
1268	179	1	Retaining Pin OE-1212	
1213	137	2	Parallelogram Lever Plunger-Top	
1334	139	2	Spring for OE-1213	
1266	180	2	Retaining Pin for OE-1213	
1214	140	1	Axis Bolt for OE-1211	
1246	149 Assy.	1	Trigger Pawl and Holder Assembly-Consists of:	
1219	149	1	Pawl Holder	
1222	151	1	Trigger Pawl	
1332	167	1	Spring for OE-1222	
1231	165	1	Axis Bolt for OE-1222	
1232	166	1	Pawl Holder Pin	



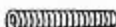





GUN MECHANISM

MK. 4 OE. NO.	MK. 2 ITEM NO.	NO. PCS.	COMPONENT	SKETCH
1242	156 Assy.	1	Trigger Pawl Tripping Plunger Assembly—Consists of:	
1225	156	1	Trigger Pawl Tripping Bolt	
1255	175	1	Retaining Pin for OE-1225	
1226	157	1	Trigger Pawl Tripping Bolt Spring Case	
1338	158	1	Spring for OE-1226	
1263	120	1	Retaining Pin for OE-1226	
1218	147	1	Trigger Intermediate Lever	
1241	159 Assy.	1	Trigger Intermediate Lever Plunger Assembly—Consists of:	
1227	159	1	Trigger Intermediate Lever Spring Case	
1333	162	1	Spring for OE-1229	
1229	161	1	Trigger Intermediate Lever Plunger	
1257	178	1	Retaining Pin for OE-1229	
1228	160	1	Distance Piece for OE-1227	













GUN MECHANISM

MK. 4 OE. NO.	MK. 2 ITEM NO.	NO. PCS.	COMPONENT	SKETCH
1243	168 Assy.	1	Trigger Cover Plate Assembly—Consists of:	
1233	168	1	Trigger Cover Plate or	
1249	168	1	Trigger Cover Plate or	
1284		1	Trigger Cover Plate and Bracket Assembly	
1234	170	1	Safety Gear Axis Bolt	
1236	174	1	Safety Cam	
1262	185	1	Safety Gear Axis Bolt Pin	
1244	189 Assy.	1	Safe/Fire Lever and Plunger Assembly—Consists of:	
1237	189	1	Safe/Fire Lever	
1328	173	1	Spring for OE-1237	
1235	172	1	Safe/Fire Lever Plunger	
1272	183	1	Retaining Pin for OE-1235	
1223	153	1	Trigger Crank	





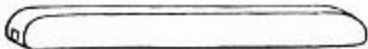







GUN MECHANISM

MK. 4 PART NO.	MK. 2 ITEM NO.	NO. PCS.	COMPONENT	SKETCH
367534-1		1	Rear Barrel Spring and Pilot Assembly (Round Wire)—Consists of: (Supersedes OE-1320)	
367533-1		1	Barrel Spring—Rear	
367534-3		1	Rear Barrel Spring Pilot	
367534-2		1	Front Barrel Spring and Spacer Assembly (Round Wire)—Consists of: (Supersedes OE-1321 and OE-1325)	
367533-2		1	Barrel Spring—Front	
367534-4		1	Barrel Spring Center Spacer	
OE-1207	131		Parallelogram Lever Axis Bolt—Top Front (Superseded by OE-1201)	
OE-1208	132	1	Parallelogram Lever Axis Bolt Sleeve—Top (Superseded by OE-1201)	
OE-1272	176	1	Parallelogram Lever Axis Bolt Sleeve Pin (Superseded by OE-1201)	
299676-7	621	12	Buffer Spring (Supersedes OE-1327)	











SHOULDER REST

MK. 4 OE. NO.	MK. 2 ITEM NO.	NO. PCS.	COMPONENT	SKETCH
<i>Mark 5 Mod. 1, Mark 5, Mark 4, and Mark 2 Shoulder Rest Assemblies are interchangeable</i>				
1499		1	Shoulder Piece Frame Assembly	
	250 Assy.	1	Shoulder Piece Frame Assembly	
1497		2	Shoulder Piece Assembly	
1517		4	Shoulder Pad Screw	
	259	2	Shoulder Piece Assembly	
	263	4	Shoulder Pad Screw	
1514		2	Shoulder Pad Assembly— (Optional with OE-1490 and OE-1704)	
	260	2	Shoulder Pad Assembly	
1490		2	Shoulder Pad and Reinforcement Assembly— Consists of: (Optional with OE-1514 and OE-1704)	
1491		2	Shoulder Pad Reinforcement Assembly	
1493		2	Shoulder Pad	
1507		1	Shoulder Rest Adjusting Spindle	









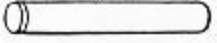

SHOULDER REST

MK. 4 OE. NO.	MK. 2 ITEM NO.	NO. PCS.	COMPONENT	SKETCH
	253	1	Shoulder Rest Adjusting Spindle	
1508		1	Shoulder Rest Adjusting Knob	
	254	1	Shoulder Rest Adjusting Knob	
1265	270	1	Shoulder Rest Adjusting Knob Pin	
1509		1	Shoulder Rest End Plug	
	255	1	Shoulder Rest End Plug	
1274		1	Shoulder Rest End Plug Pin	
	269	1	Shoulder Rest End Plug Pin	
1281		2	Shoulder Piece Ferrule Pin	
	268	2	Shoulder Piece Ferrule Pin	
1498		1	Shoulder Piece Holder Assembly	
	251	1	Shoulder Piece Holder Assembly	
1521		1	Shoulder Rest Catch Pin	

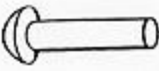





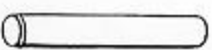



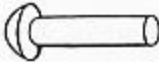

SHOULDER REST

MK. 4 OE. NO.	MK. 2 ITEM NO.	NO. PCS.	COMPONENT	SKETCH
	267	1	Shoulder Rest Catch Pin	
1510		1	Shoulder Rest Catch	
	256	1	Shoulder Rest Catch	
1511		1	Shoulder Rest Catch Spring Sleeve	
	257	1	Shoulder Rest Catch Spring Sleeve	
1512	258	1	Shoulder Rest Catch Spring	
1495		1	Shoulder Rest Strap Assembly—Consists of:	
1522		1	Shoulder Rest Strap Assembly—Right	
1523		1	Shoulder Rest Strap Assembly—Left	
	275	1	Shoulder Rest Strap—Right	
	276	1	Shoulder Rest Strap—Left	









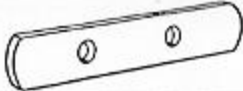

SHOULDER REST

MK. 5 OE. NO.	NO. PCS.	COMPONENT	SKETCH
1732	1	Shoulder Piece Support and Pad Assembly—Right—Consists of:	
1701	1	Shoulder Piece Support Assembly—Right—Consists of:	
1717	1	Shoulder Piece Support	
1718	3	Shoulder Piece Support Pin	
1720	1	Shoulder Strap Anchor Knob	
1288	1	Shoulder Strap Anchor Knob Rivet	
1703	1	Shoulder Piece Assembly	
1704	1	Shoulder Pad Assembly (Optional with OE-1490 and OE-1514)	
1517	2	Shoulder Pad Screw	
1733	1	Shoulder Piece Support and Pad Assembly—Left—Consists of:	
1702	1	Shoulder Piece Support Assembly—Left—Consists of:	
1717	1	Shoulder Piece Support	
1718	3	Shoulder Piece Support Pin	

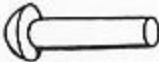









SHOULDER REST

MK. 5 OE. NO.	NO. PCS.	COMPONENT	SKETCH
1719	1	Shoulder Strap Anchor (Left only)	
1720	1	Shoulder Strap Anchor Knob	
1288	1	Shoulder Strap Anchor Knob Rivet	
1703	1	Shoulder Piece Assembly	
1704	1	Shoulder Pad Assembly (Optional with OE-1499 and OE-1514)	
1517	2	Shoulder Pad Screw	
1708	1	Shoulder Rest Frame and Hand Grips Assembly—Consists of:	
1710	1	Shoulder Rest Frame and Hand Grips	
1729	1	Shoulder Rest Cocking Tackle Anchor Pin	
1730	2	Shoulder Rest Cocking Tackle Anchor Pin Spring Retainer	
1731	1	Shoulder Rest Cocking Tackle Anchor Pin Spring	
1711	2	Shoulder Piece Support Frame Clamp Bushing—Grooved—or	
1712	2	Shoulder Piece Support Frame Clamp Bushing—Plain	

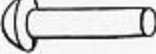



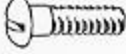





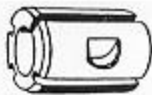

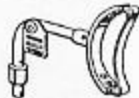
SHOULDER REST

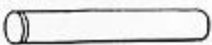
MK. 5 OE. NO.	NO. PCS.	COMPONENT	SKETCH
1713	2	Shoulder Piece Support Clamp Bushing Stop Screw	
1714	2	Shoulder Piece Support Clamping Lever	
1707	1	Shoulder Rest Strap Assembly—Consists of:	
1726	1	Shoulder Rest Strap Stop	
1727	1	Shoulder Rest Strap	
1289	2	Shoulder Rest Strap Rivet	
1705	1	Shoulder Rest Strap Buckle Assembly—Consists of:	
1706	1	Shoulder Rest Strap Buckle Partial Assembly	
1723	1	Shoulder Rest Strap Buckle Cam	
1724	1	Shoulder Rest Strap Buckle Lever	
1725	1	Shoulder Rest Strap Buckle Shaft	











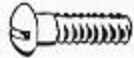

SHOULDER REST

MK. 5 MOD. 1 PART NUMBER	NO. PCS.	COMPONENT	SKETCH
300030	1	Shoulder Piece Support and Strap Assembly--Right--Consists of:	
OE-1701	1	Shoulder Piece Support Assembly--Right--Consists of:	
OE-1717	1	Shoulder Piece Support	
OE-1718	3	Shoulder Piece Support Pin	
OE-1720	1	Shoulder Strap Anchor Knob	
OE-1288	1	Shoulder Strap Anchor Knob Rivet	
300032	1	Shoulder Piece and Strap Assembly--Consists of:	
300029	1	Shoulder Piece Assembly	
300029-2	2	Shoulder Piece Clamp	
300029-3	1	Shoulder Piece Strap Assembly	
12-Z-41-252	4	Shoulder Piece Strap Screw	
12-Z-23-22	4	Shoulder Piece Strap Screw Nut	
12-Z-22-252	4	Shoulder Piece Strap Screw Lock Washer	







SHOULDER REST

MK. 5 MOD. 1 PART NUMBER	NO. PCS.	COMPONENT	SKETCH
OE-1711	1	Shoulder Piece Support Frame Clamp Bushing—Grooved—ar	
OE-1712	1	Shoulder Piece Support Frame Clamp Bushing—Plain	
300031	1	Shoulder Piece Support and Strap Assembly—Left—Consists of:	
OE-1702	1	Shoulder Piece Support Assembly—Left	
OE-1717	1	Shoulder Piece Support	
OE-1718	3	Shoulder Piece Support Pin	
OE-1719	1	Shoulder Strap Anchor (Left only)	
OE-1720	1	Shoulder Strap Anchor Knob	
OE-1288	1	Shoulder Strap Anchor Knob Rivet	
300032	1	Shoulder Piece and Strap Assembly—Consists of:	
300029	1	Shoulder Piece Assembly	
300029-2	2	Shoulder Piece Clamp	
300029-3	1	Shoulder Piece Strap Assembly	



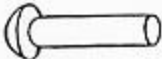



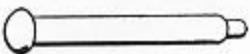



SHOULDER REST

MK. 5 MOD. 1 PART NUMBER	NO. PCS.	COMPONENT	SKETCH
12-Z-41-252	4	Shoulder Piece Strap Screw	
12-Z-23-22	4	Shoulder Piece Strap Screw Nut	
12-Z-22-252	4	Shoulder Piece Strap Screw Lock Washer	
OE-1711	1	Shoulder Piece Support Frame Clamp Bushing—Grooved—or	
OE-1712	1	Shoulder Piece Support Frame Clamp Bushing—Plain	
OE-1708	1	Shoulder Rest Frame and Hand Grips Assembly—Consists of:	
OE-1710	1	Shoulder Rest Frame and Hand Grip	
OE-1729	1	Shoulder Rest Cocking Tackle Anchor Pin	
OE-1730	2	Shoulder Rest Cocking Tackle Anchor Pin Spring Retainer	
OE-1731	1	Shoulder Rest Cocking Tackle Anchor Pin Spring	
OE-1713	2	Shoulder Piece Support Clamp Bushing Stop Screw	
OE-1714	2	Shoulder Piece Support Clamping Lever	
OE-1707	1	Shoulder Rest Strap Assembly	











SHOULDER REST

MK. 5 MOD. 1 PART NUMBER	NO. PCS.	COMPONENT	SKETCH
OE-1726	1	Shoulder Rest Strap Stop	
OE-1727	1	Shoulder Rest Strap	
OE-1289	2	Shoulder Rest Strap Rivet	
OE-1705	1	Shoulder Rest Strap Buckle Assembly	
OE-1706	1	Shoulder Rest Strap Buckle Partial Assembly	
OE-1723	1	Shoulder Rest Strap Buckle Cam	
OE-1724	1	Shoulder Rest Strap Buckle Lever	
OE-1725	1	Shoulder Rest Strap Buckle Shaft	





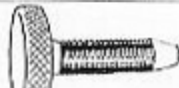
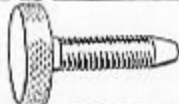





SIGHT

MK. 4 DE. NO.	MK. 2 ITEM NO.	NO. PCS.	COMPONENT	SKETCH
<i>Mark 4 and Mark 2 Sight Assemblies are interchangeable</i>				
1166		1	Sight Bracket Assembly – Consists of:	
1171		1	Sight Bracket	
1190		2	Dovetail Piece	
1191		1	Stop Piece	
1192		3	Clamping Screw	
1260		3	Sight Bracket Pin	
1163		1	Sight Bracket Assembly – Mod. 1 Consists of:	
1161		1	Sight Bracket	
1190		2	Dovetail Piece	
1191		1	Stop Piece	
1192		3	Clamping Screw	
1260		3	Sight Bracket Pin	





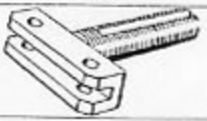





SIGHT

MK. 4 DE. NO.	MK. 2 ITEM NO.	NO. PCS.	COMPONENT	SKETCH
<i>Mark 4 and Mark 2 Sight Assemblies are interchangeable</i>				
	S-36 Assy.	1	Sight Bracket Assembly - Consists of:	
	S-36	1	Sight Bracket	
	S-22	2	Dovetail Piece	
	S-23	1	Stop Piece	
	S-24	3	Clamping Screw	
	S-33	3	Sight Bracket Pin	
1175		1	Sight Bar	
1162		1	Sight Bar Mod. 1	
	S-5	1	Sight Bar	
1186		1	Sight Bar Clamping Screw	
	S-18	1	Sight Bar Clamping Screw	
1187	S-19	1	Lock Nut for OE- 1186	





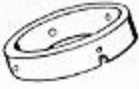





SIGHT

MK. 4 OE. NO.	MK. 2 ITEM NO.	NO. PCS.	COMPONENT	SKETCH
<i>Mark 4 and Mark 2 Sight Assemblies are interchangeable</i>				
1185		1	Sight Bar Guide Grub Screw	
	S-17	1	Sight Bar Guide Grub Screw	
1173		1	Sight Bracket Ferrule	
	S-3	1	Sight Bracket Ferrule	
1174		1	Foresight Housing	
	S-4	1	Foresight Housing	
1167		1	Foresight Assembly	
	S-37 Assy.	1	Foresight Assembly - Consists of:	
	S-37	1	Foresight	
	S-39	1	Foresight Holder	
	S-42	2	Rivet for S-37 and S-39	
	S-25	1	Sight Bracket Housing and Ferrule Pin	











SIGHT

MK. 4 OE. NO.	MK. 2 ITEM NO.	NO. PCS.	COMPONENT	SKETCH
<i>Mark 4 and Mark 2 Sight Assemblies are interchangeable</i>				
1271		1	Sight Bracket Housing and Ferrule Pin	
1195	S-15	2	Locking Washer for OE-1194	
1194		1	Foresight Adjusting Collar	
	S-14	1	Foresight Adjusting Collar	
1277		2	Foresight Bracket Bolt	
	S-29	2	Foresight Bracket Bolt	
1278		2	Lockwasher for OE-1277	
1282		1	Sight Bracket Pin	
1193	S-40	1	Baksight Ring Assembly - Consists of:	
1196		1	Baksight Ring	
1197		2	Baksight Wire	
1168		1	Baksight Assembly - Consists of:	





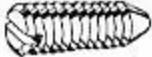



SIGHT

MK. 4 DE. NO.	MK. 2 ITEM NO.	NO. PCS.	COMPONENT	SKETCH
<i>Mark 4 and Mark 2 Sight Assemblies are interchangeable</i>				
1176		1	Baksight	
1255	175	1	Baksight Ring Locking Pin	
1180		1	Eye Piece Holder	
1198	S-35	1	Eye Piece	
1189	S-21	1	Universal Spanner	
	S-41 Assy.	1	Baksight Assembly - Consists of:	
	S-41	1	Baksight	
1255	175	1	Baksight Ring Locking Pin	
	S-10	1	Eye Piece Holder	
1198	S-35	1	Eye Piece	
1189	S-21	1	Universal Spanner	
	S-2	1	Baksight Housing	



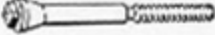







SIGHT

MK. 4 DE. NO.	MK. 2 ITEM NO.	NO. PCS.	COMPONENT	SKETCH
<i>Mark 4 and Mark 2 Sight Assemblies are interchangeable</i>				
	S-7	1	Adjusting Sleeve for S-41	
	S-8	1	Retaining Sleeve	
	S-16	2	Grub Screw	
	S-20	1	Spring	
	S-26	1	Pin for S-7 and S-38	
	S-27	1	Stop Pin for S-8	
	S-30	3	Countersunk Screw	
	S-31	1	5/32 Steel Ball	
	S-34	2	Set Screw for S-2 and S-3	
	S-38	1	Range Setting Wheel	





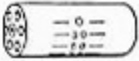

SIGHT

MK. 5 PART NUMBER	QTY. PCS.	COMPONENT	SKETCH
<i>Mark 2, Mark 4, and Mark 5 Sight Assemblies are interchangeable.</i>			
300017	1	Sight Assembly—Consists of:	
300019	1	Sight Bracket Assembly—Consists of:	
300018-1	1	Sight Bracket	
OE-1260	3	Sight Bracket Pin	
OE-1190	2	Dovetail Piece	
OE-1191	1	Stop Piece	
OE-1192	3	Clamping Screw	
300019-1	1	Foresight	
300019-2	2	Foresight to Bracket Screw	
300020	1	Rear Sight Support Assembly—Consists of:	
300020-1	1	Rear Sight Support Groove Pin	
300020-2	1	Rear Sight Support	













SIGHT

MK. 5 PART NUMBER	NO. PCS.	COMPONENT	SKETCH
300021	1	Rear Sight Collar Assembly—Consists of:	
300021-1	1	Rear Sight Collar	
300021-2	1	Rear Sight Collar Groove Pin	
300021-3	1	Rear Sight Pin	
300021-4	1	Rear Sight Collar Screw	
300021-5	1	Rear Sight Seal	
300021-6	1	Rear Sight Pin Tip	
300022	1	Elevation Indicator Drum Assembly—Consists of:	
300022-1	1	Rear Sight Range Adjustment Cylinder	
300022-2	1	Rear Sight Range Adjustment Friction Spring	
300022-3	1	Elevation Indicator Drum Weight	
300022-4	1	Elevation Indicator Drum	
300023-1	1	Elevation Indicator Drum Bearing Cap Retainer	



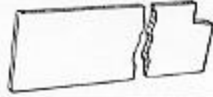





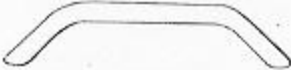

SIGHT

MK. 5 PART NUMBER	NO. PCS.	COMPONENT	SKETCH
300023-2	1	Elevation Indicator Drum Shaft	
300023-3	2	Elevation Indicator Drum Bearing Cap	
300023-4	1	Rear Sight Lateral Adjustment Screw	
300023-5	1	Rear Sight Support Screw	
300023-6	1	Rear Sight Support Screw Flat Washer	
OE-2284	1	Rear Sight Support Screw Lock Washer	



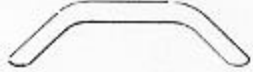

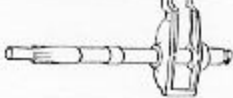





MAGAZINE

MK. 1 OE. NO.	MK. 2 ITEM NO.	NO. PCS.	COMPONENT	SKETCH
1530	OE-1530		Magazine Assembly	
1531	399	1	Magazine Front Plate Assembly – Consists of:	
1537	399	1	Magazine Front Plate	
1539	400	1	Magazine Spiral Guide – Front Outer	
1540	400	1	Magazine Spiral Guide – Front Inner	
1541	431	1	Magazine Spiral Guide Spacer	
1545	425	1	Magazine Attachment Block – Front	
1547	431	1	Magazine Spiral Guide Piece – Short	
1532	397	1	Magazine Rear Plate Assembly – Consists of:	
1543	398	1	Magazine Spiral Guide – Rear Inner	
1542	398	1	Magazine Spiral Guide – Rear Outer	
1538	397	1	Magazine Rear Plate	
1546	426	1	Magazine Attachment Block – Rear	

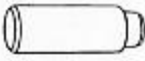









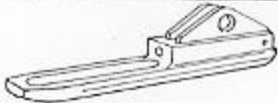

MAGAZINE

MK. 4 DE. NO.	MK. 2 ITEM NO.	NO. PCS.	COMPONENT	SKETCH
1528	401	1	Magazine Main Shaft Journal	
1296	443	3	Magazine Main Shaft Journal Rivet	
1534	423	1	Magazine Hand Grip Assembly - Rear - Consists of:	
1553	423	1	Magazine Hand Grip Rear Handle	
1555	423-A	1	Magazine Hand Grip Rear Flange - Upper	
1554	423-B	1	Magazine Hand Grip Rear Flange - Lower	
1533	424	1	Magazine Hand Grip Assembly - Front - Consists of:	
1550	424	1	Magazine Hand Grip - Front	
1552	424-A	1	Magazine Hand Grip Front Flange - Upper	
1551	424-B	1	Magazine Hand Grip Front Flange - Lower	
1600	449	1	Magazine Feed Axis Assembly - Consists of:	
1584	449-A	1	Magazine Main Shaft	
1549	407	1	Magazine Feed Block	



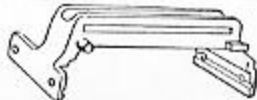







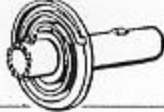

MAGAZINE

MK. 4 PART NO.	MK. 2 ITEM NO.	NO. PCS.	COMPONENT	SKETCH
OE-1294	440	2	Magazine Feed Axis Taper Pin	
OE-1599	441	1	Magazine Feed Axis Snap Ring	
OE-1573	422	1	Magazine Feed Axis Washer	
OE-1561	408	1	Magazine Feeder Arm	
299721-10		1	Magazine Stop Bolt - Short <small>(Supersedes OE-1577 and OE-1290, see page 203)</small>	
299721-11		1	Magazine Stop Bolt - Long <small>(Supersedes OE-1576 and OE-1290, see page 203)</small>	
OE-1564	412	2	Magazine Articulating Bolt	
OE-1566	414	2	Magazine Articulating Bolt Washer	
OE-1297	438	2	Cotter Pin for OE-1564	
OE-1565	413	2	Magazine Articulating Bolt Roller	
OE-1579	433	1	Magazine Cartridge Feeder Link	
OE-1563	411	1	Magazine Feed Head	







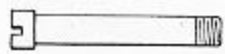

MAGAZINE

MK. 4 OE. NO.	MK. 2 OE. NO.	NO. PCS.	COMPONENT	SKETCH
1562	409	1	Magazine Feeder Swivel Bolt	
1566	414	1	Magazine Swivel Bolt Washer	
1297	438	1	Cotter Pin for OE-1562	
1567	415	1	Magazine Cartridge Feeder	
1295	442	1	Magazine Interlock Bolt Taper Pin	
1565	413	1	Magazine Interlock Bolt Sleeve Roller	
1569	417	1	Magazine Interlock Bolt Sleeve	
1568	416	1	Magazine Interlock Bolt	
1574	428	1	Spring for OE-1568	
1548	396	1	Magazine Mouth Piece	
1560	406	2	Magazine Mouth Piece Locating Cotter	
1593	432	4	Magazine Mouth Piece Screw (Supersedes OE-1578, 1594, 1580, and 1595, see page 203)	
1298	435	4	Magazine Mouth Piece Screw Nut (Supersedes OE-1292 and OE-1297, see page 203)	





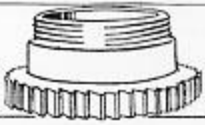



MAGAZINE

MK. 4 PART NO.	MK. 2 OE. NO.	NO. PCS.	COMPONENT	SKETCH
OE-1544	401	1	Magazine Casing	
OE-1556	410	8	Magazine Casing Bolt	
OE-1291	439	8	Magazine Casing Bolt Nut	
OE-1293	436	8	Magazine Casing Bolt Lock Washer	
299709	421	1	Magazine Spring and Case Assembly	
OE-1582	445	1	Magazine Spring Axis	
OE-1586	451	1	Magazine Spring Case Bolt	
OE-1581	444	1	Magazine Cover Plate	
OE-1583	446	1	Magazine Indicator Block	
OE-1559	404	8	Magazine Cover Screw	
OE-1293	436	8	Magazine Cover Screw Lock Washer	
OE-1529	447	1	Magazine Coupling Sleeve	
OE-1575	448	1	Magazine Coupling Spring	

MAGAZINE

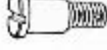
MK. 4 OE. NO.	MK. 2 ITEM NO.	NO. PCS.	COMPONENT	SKETCH
1585	450	1	Magazine Ratchet Spring Ring	
1587	452	1	Magazine Ratchet Cross Pin	
1535	M-1215	1	Magazine Lever Assembly—Consists of:	
1536	.466	1	Magazine Lever	
1527	458	1	Magazine Lever Ratchet Pawl	
1590	460	1	Magazine Lever Ratchet Pawl Screw	
1589	459	1	Spring for OE-1527	
1588	457	1	Magazine Lever Set Screw	
1596	455	1	Magazine Ratchet Wheel	
1290	427	1	Magazine Lever Set Screw Nut	
1598	456	1	Magazine Lever Set Screw Collar	

MAGAZINE

MK. 4 OE. NO.	MK. 2 ITEM NO.	NO. PCS.	COMPONENT	SKETCH
1577	430	1	Magazine Stop Bolt—Short (Superseded by 299721-10)	
1576	429	1	Magazine Stop Bolt—Long (Superseded by 299721-11)	
1290	427	1	Magazine Stop Bolt Nut (Used only with OE-1577 and OE-1576)	
1594	432	1	Magazine Mouth Piece Screw—Front Short (Superseded by OE-1593 and OE-1298)	
1595	434	1	Magazine Mouth Piece Screw—Front Long (Superseded by OE-1593 and OE-1298)	
1580	434	1	Magazine Mouth Piece Screw—Rear Long (Superseded by OE-1593 and OE-1298)	
1578	432	1	Magazine Mouth Piece Screw—Rear Short (Superseded by OE-1593 and OE-1298)	
1292	435	4	Magazine Mouth Piece Screw Nut (Used only with OE-1594, 1595, 1580, and 1578)	
1297	438	4	Magazine Mouth Piece Screw Nut Cotter Pin (Used only with OE-1594, 1595, 1580 and 1578)	



GUN TOOLS AND ACCESSORIES

MK. 4 PART NO.	MK. 2 ITEM NO.	NO. PCS.	COMPONENT	SKETCH
OE-1605	60/1	1	8 oz. Cross Peen Hammer	See Page 130
OE-1606	60/2	1	Adjustable Wrench	See Page 130
OE-1622	59/1	1	Cartridge Case Extractor Tool	See Page 130
OE-1620	59/10	1	Double Loading Stop Bushing Spanner	See Page 130
OE-1619	59/6	1	Breech Face Piece Spanner	See Page 130
367516-3		1	Breech Face Piece Removing Tool	See Page 130
OE-1621	58/3	1	Barrel Spring Seating Ring Spanner	See Page 130
300009-1		1	Barrel Removing Tool	See Page 130
367516-1		1	Cleaning Rod and Handle Assembly	See Page 130
OE-1634	57/1/4	1	Cleaning Rod Brush Assembly	See Page 130
299817-5		1	Cleaning Rod Bag and Brush End Assembly	See Page 130
367516-2		1	Cleaning Rod Ejector Assembly	See Page 130
OE-1608	60/4	1	Pliers—External	See Page 130







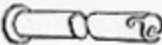





GUN TOOLS AND ACCESSORIES

MK. 4 PART NO.	MK. 2 ITEM NO.	NO. PCS.	COMPONENT	SKETCH
OE-1609	60/5	1	Pliers-Internal	See Page 130
OE-1607	60/3	1	Brush	See Page 130
OE-1637		1	Grease Gun-or	See Page 130
299832-5		1	Grease Gun	See Page 130
OE-1612		1	Grease Retainer	See Page 130
299846-3		1	Oiler	See Page 130
OE-1616	60/12	1	Drift	See Page 130
OE-1613	60/10	1	Punch-Small	See Page 130
OE-1614	60/9	1	Punch for Removing Hammer Plate	See Page 130
OE-1615	60/11	1	Punch-Large	See Page 130
OE-1610	OE-1610	1	5" Screw Driver-Large	See Page 130
OE-1629	OE-1629	1	Screw Driver-Small	See Page 130
OE-1635	OE-1635	1	Screw Driver-For Barrel Screw	See Page 130

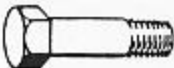







GUN TOOLS AND ACCESSORIES

MK. 4 PART NO.	MK. 2 ITEM NO.	NO. PCS.	COMPONENT	SKETCH
OE-1628	61/2	1	5" File	See Page 130
OE-1627	61/2	1	File Handle	See Page 130
OE-1636		2 pr.	Asbestos Gloves	
367532-1		1	Tool Roll	
2997 12-7		1	Magazine Loading Tool	See Page 130
367524		1	Magazine Loading Tool Assembly	
OE-1591	OE-1591	1	Magazine Loading Frame	
OE-1189		1	Sight Universal Spanner	See Page 130
367523-1		1	Sight Socket Wrench Handle	See Page 130
367523-2		1	Sight Socket Wrench Socket 1/4"	See Page 130
367523-3		1	Sight Double End Wrench	See Page 130
367523-4		1	Sight Allen Type Wrench	See Page 130
OE-1617	58/2	1	Barrel Spring Holder—Internal	











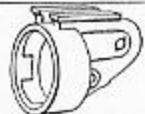

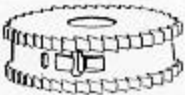
COCKING TOOLS

OE. NUMBER	NO. PCS.	COMPONENT	SKETCH
3530	1	Gun Cocking Hook and Rope Assembly—Mark 4— Consists of:	
3531	1	Gun Cocking Hook	
3532	1	Gun Cocking Rope	
3542	1	Gun Cocking Tackle and Holder Assembly—Mark 2— Consists of:	
3544	1	Gun Cocking Tackle Front Sheave Carrier	
3545	1	Gun Cocking Tackle Rear Sheave Carrier	
3549	2	Gun Cocking Tackle Cable Clamp	
3550	2	Gun Cocking Tackle Cable Clamp Bolt	
3551	2	Gun Cocking Tackle Cable Clamp Bolt Nut	
3552	2	Gun Cocking Tackle Cable Clamp Bolt Lock Washer	
3553	1	Gun Cocking Tackle Cable Assembly	
3554	1	Gun Cocking Tackle Cable Nut	
3555	1	Gun Cocking Tackle Cable Handle	





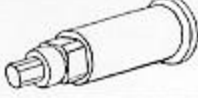







COCKING TOOLS

PART NUMBER	NO. PCS.	COMPONENT	SKETCH
OE-3561	1	Gun Cocking Tackle Holder Assembly	
OE-3556	1	Gun Cocking Tackle Shoulder Pin	
OE-3557	1	Gun Cocking Tackle Shoulder Pin Lock Nut	
OE-3558	1	Gun Cocking Tackle Shoulder Pin Washer	
OE-3548	2	Gun Cocking Tackle Groove Pin	
OE-3559	2	Gun Cocking Tackle Sheave Pin	
OE-3560	9	Gun Cocking Tackle Cable Sheave	
OE-2029	1	Wire Rope Assembly	
299905	1	Cocking Lanyard—Mark 3 (Stirrup type)	













COCKING TOOLS

MK. 4 OE. NO.	MK. 2 ITEM NO.	NO. PCS.	COMPONENT	SKETCH
	HC-200	1	Housing	
	HC-201	1	Fork	
	HC-202	1	Ratchet Wheel	
	HC-203	1	Steel Strip	
	HC-204	1	Ratchet Sleeve	
	HC-205	1	Handle Pawl	
	HC-206	1	Handle	
	HC-208	1	Cover Plate	
	HC-209	1	Hook	
	HC-210	1	Bushing for HC-215	
	HC-211	1	Holding Pawl	
	HC-212	1	Bolt for HC-211	
	HC-213	1	Lever for Holding Pawl	

COCKING TOOLS

MK. 4 OE. NO.	MK. 2 ITEM NO.	NO. PCS.	COMPONENT	SKETCH
	HC-214	1	Catch for HC-213	
	HC-215	1	Main Axis Bolt	
	HC-216	1	Spring Catch	
	HC-217	1	Sleeve for HC-228	
	HC-218	1	Key for HC-215	
	HC-219	1	Spring Plunger for HC-216	
	HC-220	1	Spiral Spring	
	HC-221	1	Spring for HC-219	
	HC-222	1	Spring for HC-214	
	HC-223	1	Connecting Link	
	HC-224	1	Circlip for HC-215	
	HC-225	1	Pin for HC-203	
	HC-226	1	Pin for HC-216	

COCKING TOOLS

MK. 4 QE. NO.	MK. 2 ITEM NO.	NO. PCS.	COMPONENT	SKETCH
	HC-227	1	Pin for HC-220	
	HC-228	2	Pin for HC-202	
	HC-229	1	Pin for HC-209	
	HC-230	1	Bolt for HC-205	
	HC-231	1	Bolt for HC-216	
	HC-232	1	Bolt for HC-214	
	HC-233	4	Washer for HC-209 and 223	
	HC-234	1	Pin for HC-210	
	HC-235	1	Spring for HC-211	
	HC-236	1	Chain	
	HC-237	4	Countersunk Screw for HC-208	
	HC-238	3	Rivet for HC-203	
	HC-239	2	Pin for HC-209 and 223	

CROSS INDEX TO OE AND BUREAU OF ORDNANCE NUMBERS

CROSS INDEX TO OE—DRAWING NUMBERS

OE NUMBER	BUREAU OF ORDNANCE			OE NUMBER	BUREAU OF ORDNANCE			OE NUMBER	BUREAU OF ORDNANCE		
	DRAWING No.	PC. No.	PAGE No.		DRAWING No.	PC. No.	PAGE No.		DRAWING No.	PC. No.	PAGE No.
OE-1000 SHEET 1	299825	Ass'y		OE-1052	299671	-5	169	OE-1103	299659	-1	165
OE-1000 SHEET 2	299826	Ass'y		OE-1053	299674	-5	170	OE-1104	299659	-2	165
OE-1001	299827	Ass'y	163	OE-1054	299674	-1	170	OE-1105	299883	-1	166
OE-1003	299902	Ass'y	163	OE-1055	299675	-2	170	OE-1106	299882	Ass'y	
OE-1010-FP	299650	-2		OE-1056	299676	-5	166	OE-1107	299882	-1	
OE-1010	299650	-1	163	OE-1057	299678	-4	167	OE-1108	299882	-2	
OE-1011	299827	-1	163	OE-1058	299676	-1	167	OE-1160	299821	Ass'y	
OE-1011-SC	299827	-3		OE-1059	299671	-3	169	OE-1161	299823	-1	188
OE-1012	299827	-2	163	OE-1060	299677	-2	170	OE-1162	299822	-1	189
OE-1013	299901	-1	163	OE-1061	299682	-1		OE-1163	299822	Ass'y	188
OE-1014	299902	-1	163	OE-1062	299683	-2	171	OE-1166	299699	Ass'y	188
OE-1015	299902	-2	163	OE-1063	299675	-1	170	OE-1167	299703	-1	190
OE-1016	299902	-3	163	OE-1064	299677	-1	70	OE-1168	299702	Ass'y	191
OE-1029	299671	Ass'y		OE-1065	299683	-4	171	OE-1170	299699	Ass'y	
OE-1030	299824	Ass'y		OE-1066	299680	-1	167	OE-1171	299700	-1	188
OE-1031	299669	Ass'y		OE-1067	299680	-2	168	OE-1173	299701	-4	190
OE-1032	299824	Ass'y		OE-1068	299683	-3	171	OE-1174	299704	-1	190
OE-1033	299677	Ass'y	170	OE-1069	299675	-4	170	OE-1175	299701	-1	189
OE-1034	299680	Ass'y		OE-1070	299673	-3	168	OE-1176	299702	-4	192
OE-1035	299678	Ass'y	168	OE-1071	299674	-2	170	OE-1180	299705	-2	192
OE-1036	299736	Ass'y	171	OE-1072	299671	-1	169	OE-1185	299701	-2	190
OE-1037	299680	Ass'y		OE-1073	299676	-6	167	OE-1186	299701	-3	189
OE-1038	299683	Ass'y	171	OE-1074	299680	-4	167	OE-1187	299704	-6	189
OE-1039	299672	Ass'y	169	OE-1075	299680	-6	168	OE-1189	299704	-7	192
OE-1040	299670	-1	166	OE-1076	299678	-3	168	OE-1190	299705	-6	188
OE-1043	299679	-1	168	OE-1077	299678	-2	168	OE-1191	299705	-3	188
OE-1044	299657	-2	165	OE-1078	299673	-1	168	OE-1192	299704	-8	188
OE-1045	299681	-1	167	OE-1079	299673	-2	168	OE-1193	299702	Ass'y	191
OE-1046	299679	-2	168	OE-1080	299674	-4	169	OE-1194	299704	-2	191
OE-1047	299657	-3	165	OE-1081	299675	-3	170	OE-1195	299704	-3	191
OE-1048	299655	-2	164	OE-1082	299736	-5		OE-1196	299702	-2	191
OE-1049	299672	-1	169	OE-1083	299671	-6		OE-1197	299702	-3	191
OE-1050	299672	-2	169	OE-1084	299671	-7		OE-1198	299705	-1	192
OE-1051	299672	-5	169	OE-1085	299671	-8		OE-1199	299705	-4 -7	
				OE-1102	299667	-1	166				

CROSS INDEX TO OE—DRAWING NUMBERS

OE NUMBER	BUREAU OF ORDNANCE			OE NUMBER	BUREAU OF ORDNANCE			OE NUMBER	BUREAU OF ORDNANCE		
	DRAWING No.	PC. No.	PAGE No.		DRAWING No.	PC. No.	PAGE No.		DRAWING No.	PC. No.	PAGE No.
OE-1200	299689	Ass'y	172	OE-1238	299684	-3	171	OE-1285	299694	-1	
OE-1201	299695	-6	172	OE-1240	299689	Ass'y		OE-1286	299695	-1	
OE-1202	299685	-1	171	OE-1241	299697	Ass'y	174	OE-1287	299695	-4	
OE-1203	299690	-1	172	OE-1242	299692	Ass'y	174	OE-1288	299897	-4	181
OE-1204	299689	-2	172	OE-1243	299693	Ass'y	175	OE-1289	299899	-2	183
OE-1205	299690	-4	172	OE-1244	299696	Ass'y	175	OE-1290	299718	-3	202
OE-1206	299689	-1	172	OE-1245	299684	Ass'y	171	OE-1291	299724	-5	201
OE-1207	299690	-3	177	OE-1246	299691	Ass'y	173	OE-1292	299726	-6	203
OE-1208	299690	-6	177	OE-1247	299687	Ass'y	172	OE-1293	299723	-4	201
OE-1209	299690	-2	172	OE-1248	299684	Ass'y		OE-1294	299714	-1	199
OE-1210	299690	-8	172	OE-1249	299829	-1	175	OE-1295	299727	-4	200
OE-1211	299687	-1	172	OE-1250	299678	-1	168	OE-1296	299712	-5	198
OE-1212	299687	-2	173	OE-1253	299655	-1	164	OE-1297	299721	-7	199
OE-1213	299687	-3	173	OE-1254	299657	-1	165	OE-1298	299727	-8	200
OE-1214	299688	-2	173	OE-1255	299692	-5	174	OE-1301	299651	Ass'y	164
OE-1215	299684	-1	171	OE-1256	299690	-5	172	OE-1302	299659	Ass'y	
OE-1216	299686	-1	171	OE-1257	299697	-3	174	OE-1303	299651	Ass'y	164
OE-1217	299686	-2	171	OE-1258	299683	-6	171	OE-1304	299652	-1	164
OE-1218	299698	-2	174	OE-1260	299702	-5	188	OE-1305	299651	-1	164
OE-1219	299692	-1	173	OE-1261	299680	-5	167	OE-1306	299651	-2	164
OE-1220	299698	-3	176	OE-1262	299695	-5	175	OE-1307	299653	-1	164
OE-1221	299698	-4	176	OE-1263	299671	-4	174	OE-1308	299654	-1	164
OE-1222	299691	-2	173	OE-1265	299672	-6	169	OE-1309	299653	-2	164
OE-1223	299698	-1	175	OE-1266	299688	-3	173	OE-1310	299656	-1	164
OE-1224	299686	-4	176	OE-1267	299676	-4	167	OE-1311	299658	-1 -2	165
OE-1225	299692	-2	174	OE-1268	299688	-4	173	OE-1312	299655	Ass'y	164
OE-1226	299692	-3	174	OE-1269	299676	-3	167	OE-1313	299657	Ass'y	164
OE-1227	299697	-2	174	OE-1270	299672	-3	169	OE-1315	299660	-1	165
OE-1228	299697	-5	174	OE-1271	299702	-1	191	OE-1316	299666	-1	165
OE-1229	299697	-1	174	OE-1272	299690	-7	175	OE-1317	299665	-1	165
OE-1230	299686	-3	176	OE-1274	299740	-1	179	OE-1318	299667	-2	166
OE-1231	299691	-1	173	OE-1277	299704	-5	191	OE-1319	299665	-2	165
OE-1232	299692	-6	173	OE-1278	299704	-4	191	OE-1320	299668	-1	166
OE-1233	299828	-1	175	OE-1279	299688	Ass'y	171	OE-1321	299668	-2	166
OE-1234	299695	-3	175	OE-1281	299740	-6	179	OE-1322	299650	-3	166
OE-1235	299695	-3	175	OE-1282	299701	-5	191	OE-1323	299666	-2	166
OE-1236	299695	-2	175	OE-1283	299736	-3		OE-1324	299666	-3	166
OE-1237	299696	-2	175	OE-1284	299694	Ass'y	175				

CROSS INDEX TO OE—DRAWING NUMBERS

OE NUMBER	BUREAU OF ORDNANCE			OE NUMBER	BUREAU OF ORDNANCE			OE NUMBER	BUREAU OF ORDNANCE		
	DRAWING No.	Pc. No.	PAGE No.		DRAWING No.	Pc. No.	PAGE No.		DRAWING No.	Pc. No.	PAGE No.
OE-1325	299667	-3	166	OE-1503	299736	-1		OE-1541	299709	-1	197
OE-1326	299697	-6	176	OE-1504	299732	-1		OE-1542	299712	-2	197
OE-1327	299678	-5	167	OE-1505	299733	-2		OE-1543	299712	-1	197
OE-1328	299696	-1	175	OE-1506	299731	-1		OE-1544	299724	-1	201
OE-1329	299659	-4	166	OE-1507	299739	-4	178	OE-1545	299709	-2	197
OE-1330	299680	-3	167	OE-1508	299739	-6	179	OE-1546	299712	-3	197
OE-1331	299671	-2	169	OE-1509	299739	-5	179	OE-1547	299708	-2	197
OE-1332	299691	-3	173	OE-1510	299740	-4	180	OE-1548	299725	-1	200
OE-1333	299697	-4	174	OE-1511	299740	-3	180	OE-1549	299715	-1	198
OE-1334	299688	-1	173	OE-1512	299740	-5	180	OE-1550	299719	-2	198
OE-1335	299683	-5	171	OE-1513	299730	-2		OE-1551	299719	-3	198
OE-1336	299674	-3	170	OE-1514	299737	-1	178	OE-1552	299719	-1	198
OE-1337	299676	-2	167	OE-1515	299738	-1		OE-1553	299713	-1	198
OE-1338	299692	-4	174	OE-1516	299733	-1		OE-1554	299713	-2	198
OE-1339	299673	-4	169	OE-1517	299739	-3	178	OE-1555	299713	-3	198
OE-1340	299681	-2	168	OE-1518	299739	-2		OE-1556	299724	-2	201
OE-1341	299665	-3	165	OE-1519	299730	-1		OE-1557	299724	-3	
OE-1342	299687	-4	173	OE-1520	299732	-3		OE-1558	299724	-4	
OE-1343	299684	-2	172	OE-1521	299740	-2	179	OE-1559	299723	-3	201
OE-1344	299675	-5	170	OE-1522	299735	-1	180	OE-1560	299726	-1	200
OE-1345	299672	-4	169	OE-1523	299735	-2	180	OE-1561	299719	-4	199
OE-1346	299665	-4	165	OE-1524	299734	-1		OE-1562	299720	-2	200
OE-1359	299918	Ass'y		OE-1525	299724	-2		OE-1563	299721	-2	199
OE-1360	299918	-1		OE-1526	299736	-2		OE-1564	299721	-5	199
OE-1361	299918	-2		OE-1527	299717	-1	202	OE-1565	299721	-8	199
OE-1490	299738	Ass'y	178	OE-1528	299712	-4	198	OE-1566	299721	-6	199
OE-1491	299738	Ass'y	178	OE-1529	299726	-8	201	OE-1567	299720	-1	200
OE-1492	299738	-2		OE-1530	299706	Ass'y	197	OE-1568	299727	-3	200
OE-1493	299739	-1	178	OE-1531	299707	Ass'y	197	OE-1569	299727	-5	200
OE-1494	299736	-4		OE-1532	299710	Ass'y	197	OE-1570	299716	-2	
OE-1495	299734	Ass'y	180	OE-1533	299719	Ass'y	198	OE-1571	299716	-1	
OE-1496	299737	Ass'y		OE-1534	299713	Ass'y	198	OE-1572	299722	-1	
OE-1497	299730	Ass'y	178	OE-1535	299717	Ass'y	202	OE-1573	299720	-4	199
OE-1498	299733	Ass'y	179	OE-1536	299717	-2	202	OE-1574	299727	-6	200
OE-1499	299731	Ass'y	178	OE-1537	299708	-1	197	OE-1575	299726	-9	201
OE-1500	299729	Ass'y		OE-1538	299711	-1	197	OE-1576	299721	-4	203
OE-1501	299731	Ass'y		OE-1539	299708	-3	197	OE-1577	299721	-3	203
OE-1502	299732	-2		OE-1540	299708	-4	197	OE-1578	299726	-2	203

CROSS INDEX TO OE—DRAWING NUMBERS

OE NUMBER	BUREAU OF ORDNANCE			OE NUMBER	BUREAU OF ORDNANCE			OE NUMBER	BUREAU OF ORDNANCE		
	DRAWING No.	PC. No.	PAGE No.		DRAWING No.	PC. No.	PAGE No.		DRAWING No.	PC. No.	PAGE No.
OE-1579	299721	-1 -9	199	OE-1619	299815	-1	204	OE-1714	299894	-4	183
OE-1580	299726	-4	203	OE-1620	299817	-2	204	OE-1715	299900	-1	
OE-1581	299723	-1	201	OE-1621	299814	-3	204	OE-1716	299894	-1	
OE-1582	299722	-2	201	OE-1622	299815	Ass'y	204	OE-1717	299897	-1	181
OE-1583	299726	-7	201	OE-1623	299815	-2		OE-1718	299897	-3	181
OE-1584	299714	-2	198	OE-1624	299815	-3		OE-1719	299897	-5	182
OE-1585	299727	-1	202	OE-1625	299815	-4		OE-1720	299897	-2	181
OE-1586	299723	-2	201	OE-1626	299815	-5		OE-1721	299899	-1	
OE-1587	299727	-2	202	OE-1627	299818	-1	206	OE-1722	299898	-4	
OE-1588	299718	-2	202	OE-1628	299818	-2	206	OE-1723	299898	-3	183
OE-1589	299718	-1	202	OE-1629	299819	-4	205	OE-1724	299898	-1	183
OE-1590	299717	-3	202	OE-1630	299816	-1		OE-1725	299898	-2	183
OE-1591	299728	-1	206	OE-1631	299816	-2		OE-1726	299899	-4	183
OE-1593	299727	-7	200	OE-1632	299817	-1		OE-1727	299899	-3	183
OE-1594	299726	-3	203	OE-1633	299816	-3		OE-1728	299906	-1	
OE-1595	299726	-5	203	OE-1634	299816	-4	204	OE-1729	299895	-1	182
OE-1596	299718	-4	202	OE-1635	299819	-1	205	OE-1730	299895	-2	182
OE-1598	299718	-5	202	OE-1636	299819	-6	206	OE-1731	299895	-3	182
OE-1599	299720	-3	199	OE-1637	299832	-1	205	OE-1732	299984	Ass'y	181
OE-1600	299714	Ass'y	198	OE-1638	299830	Ass'y		OE-1733	299983	Ass'y	181
OE-1601	299716	Ass'y		OE-1639	299830	-1		OE-1865	OS-1158		
OE-1603	299814	Ass'y		OE-1640	299830	-2		OE-2000	299741	Ass'y	
OE-1604	299820	-1		OE-1641	299830	-4		OE-2001	299756	Ass'y	
OE-1605	299819	-5	204	OE-1642	299830	-5		OE-2002	299756	Ass'y	
OE-1606	299814	-4	204	OE-1643	299830	-3		OE-2003	299750	Ass'y	
OE-1607	299817	-3	205	OE-1700	299893	Ass'y		OE-2004	299749	Ass'y	
OE-1608	299818	-5	204	OE-1701	299897	Ass'y	181	OE-2005	299760	Ass'y	
OE-1609	299818	-6	205	OE-1702	299897	Ass'y	181	OE-2006	299758	Ass'y	
OE-1610	299819	-3	205	OE-1703	299894	Ass'y	181	OE-2007	299757	Ass'y	
OE-1611	299818	-4		OE-1704	299900	Ass'y	181	OE-2008	299786	Ass'y	
OE-1612	299818	-3	205	OE-1705	299898	Ass'y	183	OE-2009	299786	Ass'y	
OE-1613	299818	-7	205	OE-1706	299898	Ass'y	183	OE-2010	299742	-1	
OE-1614	299819	-2	205	OE-1707	299899	Ass'y	183	OE-2011	299772	-1	
OE-1615	299818	-8	205	OE-1708	299895	Ass'y	182	OE-2012	299760	-1	
OE-1616	299817	-4	205	OE-1710	299896	-1	182	OE-2013	299749	-1	
OE-1617	299814	-1	206	OE-1711	299894	-2	182	OE-2014	299750	-2	
OE-1618	299814	-2	207	OE-1712	299894	-3	182	OE-2015	299751	-5	
				OE-1713	299894	-5	183	OE-2016	299761	-1	

CROSS INDEX TO OE—DRAWING NUMBERS

OE NUMBER	BUREAU OF ORDNANCE			OE NUMBER	BUREAU OF ORDNANCE			OE NUMBER	BUREAU OF ORDNANCE		
	DRAWING No.	Pc. No.	PAGE No.		DRAWING No.	Pc. No.	PAGE No.		DRAWING No.	Pc. No.	PAGE No.
OE-2017	299751	-2		OE-2070	299786	-1		OE-2108	299777	-3	
OE-2029	299782	-1	209	OE-2071	299786	-5		OE-2109	299770	-6	
OE-2030	299789	-1		OE-2072	299786	-2		OE-2110	299779	-1	
OE-2031	299791	-1		OE-2073	299787	-5		OE-2111	299771	-1	
OE-2032	299790	-1		OE-2074	299786	-3		OE-2112	299764	-1	
OE-2033	299763	-1		OE-2075	299768	-3		OE-2114	299753	-1	
OE-2034	299787	-3		OE-2076	299768	-4		OE-2115	299770	-3	
OE-2035	299768	-1		OE-2077	299773	-4		OE-2116	299755	-3	
OE-2036	299787	-4		OE-2078	299790	-4		OE-2117	299769	-2	
OE-2037	299748	-4		OE-2079	299752	-1		OE-2118	299769	-3	
OE-2038	299748	-1		OE-2080	299754	-1		OE-2119	299771	-4	
OE-2039	299748	-2		OE-2081	299759	-2		OE-2120	299770	-2	
OE-2040	299747	Ass'y		OE-2082	299757	-1		OE-2121	299770	-5	
OE-2041	299747	-1		OE-2083	299758	-1		OE-2123	299780	-2	
OE-2042	299747	-2		OE-2084	299768	-5		OE-2125	299778	-6	
OE-2043	299747	-3		OE-2085	299762	-2		OE-2126	299755	-1	
OE-2045	299748	-3		OE-2086	299748	Ass'y		OE-2127	299777	-1	
OE-2046	299745	-3		OE-2087	299777	Ass'y		OE-2128	299777	-4	
OE-2047	299745	-5		OE-2088	299753	Ass'y		OE-2129	299767	-1	
OE-2048	299745	-6		OE-2089	299762	Ass'y		OE-2132	299808	-2	
OE-2049	299745	-4		OE-2090	299762	-3		OE-2133	299808	-1	
OE-2050	299780	-4		OE-2091	299770	Ass'y		OE-2134	299762	-4	
OE-2051	299780	-3		OE-2092	299787	-2		OE-2135	299778	-5	
OE-2053	299780	-5		OE-2093	299767	-4		OE-2136	299781	-3	
OE-2054	299766	-4		OE-2094	299768	-2		OE-2137	299781	-4	
OE-2055	299745	-1		OE-2095	299791	-2		OE-2138	299778	-3	
OE-2056	299755	-2		OE-2096	299791	-5		OE-2139	299778	-1	
OE-2057	299766	-1		OE-2097	299759	-4		OE-2140	299786	-4	
OE-2060	299744	-1		OE-2098	299769	-1		OE-2141	299786	-6	
OE-2061	299787	-1		OE-2099	299771	-5		OE-2142	299781	-2	
OE-2062	299759	-1		OE-2100	299769	Ass'y		OE-2143	299750	-1	
OE-2063	299758	-3		OE-2101	299774	Ass'y		OE-2144	299804	-3	
OE-2064	299757	-5		OE-2102	299775	Ass'y		OE-2145	299807	-2	
OE-2065	299758	-2		OE-2103	299778	Ass'y		OE-2146	299783	-1	
OE-2066	299757	-3		OE-2104	299776	-1		OE-2147	299783	-2	
OE-2067	299759	-3		OE-2105	299746	-1		OE-2148	299783	-3	
OE-2068	299757	-4		OE-2106	299767	-3		OE-2149	299782	Ass'y	
OE-2069	299790	-2		OE-2107	299765	-1		OE-2151	299749	-2	

CROSS INDEX TO OE—DRAWING NUMBERS

OE NUMBER	BUREAU OF ORDNANCE			OE NUMBER	BUREAU OF ORDNANCE			OE NUMBER	BUREAU OF ORDNANCE		
	DRAWING No.	PC. No.	PAGE No.		DRAWING No.	PC. No.	PAGE No.		DRAWING No.	PC. No.	PAGE No.
OE-2152	299751	-6		OE-2191	299798	-4		OE-2234	299770	-4	
OE-2153	299788	-1		OE-2192	299803	-1		OE-2235	299771	-3	
OE-2154	299805	-7		OE-2193	299804	-1		OE-2236	299755	-4	
OE-2155	299751	-1		OE-2194	299804	-2		OE-2238	299755	-5	
OE-2157	299796	Ass'y		OE-2195	299805	-4		OE-2239	299766	-2	
OE-2158	299793	-1		OE-2196	299803	-2		OE-2240	299745	-2	
OE-2159	299792	-1		OE-2197	299803	-3		OE-2241	299746	-2	
OE-2160	299798	-1		OE-2198	299801	Ass'y		OE-2242	299747	-4	
OE-2161	299798	-2		OE-2199	299803	-4		OE-2243	299777	-2	
OE-2162	299798	-3		OE-2200	299803	-7		OE-2244	299757	-2	
OE-2163	299797	-5		OE-2201	299803	-5		OE-2245	299781	-1	
OE-2164	299796	-1		OE-2202	299803	-6		OE-2246	299780	-6	
OE-2165	299788	-2		OE-2203	299806	Ass'y		OE-2247	299762	-1	
OE-2166	299796	-2		OE-2204	299807	Ass'y		OE-2248	299788	-4	
OE-2167	299797	-1		OE-2205	299794	Ass'y		OE-2249	299788	-6	
OE-2168	299797	-2		OE-2206	299801	-1		OE-2250	299751	-4	
OE-2169	299797	-4		OE-2207	299799	Ass'y		OE-2251	299767	-2	
OE-2170	299799	-3		OE-2210	299805	-1		OE-2253	299781	-5	
OE-2171	299808	Ass'y		OE-2211	299805	-5		OE-2254	299766	-3	
OE-2172	299809	-3		OE-2212	299784	-1		OE-2255	299772	-2	
OE-2173	299809	-2		OE-2213	299784	-2		OE-2256	299788	-3	
OE-2174	299795	-1		OE-2217	299813	-3		OE-2257	299771	-2	
OE-2175	299795	-2		OE-2218	299813	-2		OE-2258	299778	-4	
OE-2176	299799	-1		OE-2219	294317	-1		OE-2259	12-Z-339 #7		
OE-2177	299800	-2		OE-2220	299811	Ass'y		OE-2260	299788	-5	
OE-2178	299800	-3		OE-2221	299811	Ass'y		OE-2261	299794	-5	
OE-2179	299800	-1		OE-2222	299812	-1		OE-2262	299794	-4	
OE-2180	299804	-5		OE-2223	299812	-2		OE-2263	299795	-3	
OE-2181	299805	-6		OE-2224	299811	-1		OE-2265	299801	-2	
OE-2182	299807	-1		OE-2225	299811	-2		OE-2267	299806	-2	
OE-2183	299806	-1		OE-2226	299813	-1		OE-2268	299797	-6	
OE-2184	299804	-4		OE-2227	299813	-4		OE-2269	299798	-5	
OE-2185	299800	-6		OE-2228	299813	-6		OE-2270	12-Z-22 #252		
OE-2186	299807	-3		OE-2229	299813	-5		OE-2271	12-Z-22 #253		
OE-2187	299802	Ass'y		OE-2230	12-Z-48 #12			OE-2272	12-Z-22 #254		
OE-2188	299794	-1		OE-2231	12-Z-48 #25			OE-2273	299772	-3	
OE-2189	299794	-3		OE-2232	12-Z-48 #40			OE-2274	299780	-1	
OE-2190	299794	-2		OE-2233	299751	-3		OE-2275	12-Z-22 #256		

CROSS INDEX TO OE—DRAWING NUMBERS

OE NUMBER	BUREAU OF ORDNANCE			OE NUMBER	BUREAU OF ORDNANCE			OE NUMBER	BUREAU OF ORDNANCE		
	DRAWING No.	PC. No.	PAGE No.		DRAWING No.	PC. No.	PAGE No.		DRAWING No.	PC. No.	PAGE No.
OE-2277	290790	-3		OE-2317	299810	Ass'y		OE-2818	299953	-3	
OE-2278	299797	-3		OE-2318	299808	Ass'y		OE-2819	299954	-1	
OE-2279	299799	-2		OE-2319	299807	Ass'y		OE-2820	299955	-1	
OE-2280	299803	-8		OE-2320	299808	Ass'y		OE-2821	299956	-1	
OE-2282	299705	-5		OE-2321	299784	-5		OE-2822	299955	-2	
OE-2283	299773	-5		OE-2322	300026	-1		OE-2823	299954	-2	
OE-2284	299783	-6	196	OE-2325	300010	-1		OE-2824	299954	-3	
OE-2285	299781	-7		OE-2328	300005	Ass'y	207	OE-2825	299955	-3	
OE-2286	299781	-6		OE-2329	300006	-1		OE-2826	299955	-4	
OE-2287	299781	-8		OE-2330	300006	-2		OE-2827	299956	Ass'y	
OE-2288	299784	-4		OE-2331	300006	-3		OE-2828	299956	-3	
OE-2289	294317	-3		OE-2332	300007	-1		OE-2829	299956	-2	
OE-2290	294317	-2		OE-2333	300007	-2		OE-2830	299956	-4	
OE-2291	299805	-2		OE-2334	300007	-3		OE-2831	300009	List	
OE-2292	299805	-3		OE-2335	300008	-1		OE-2832	299952	Ass'y	
OE-2293	299784	-3		OE-2336	300008	-2		OE-2833	299802	List	
OE-2294	299773	-1		OE-2337	300008	-3		OE-2834	299955	-5	
OE-2295	299773	-2		OE-2340	299800	-5		OE-2835	299955	-6	
OE-2296	299773	-3		OE-2341	300008	-4		OE-2836	299958	-1	
OE-2297	299783	-4		OE-2342	300008	-5		OE-2837	299953	List	
OE-2298	299783	-5		OE-2800	299953	-2		OE-2839	299904	List	
OE-2300	299791	-8		OE-2801	299977	-2		OE-2840	299906	List	
OE-2301	299800	-7		OE-2802	299977	-6		OE-2841	299972	-1	
OE-2302	299778	-2		OE-2803	299957	-4		OE-2842	299974	-1	
OE-2303	299809	-1		OE-2804	299957	-1		OE-2843	299973	-1	
OE-2304	299771	-6		OE-2805	299957	-6		OE-2844	299972	-2	
OE-2305	299771	-7		OE-2806	299977	-5		OE-2845	299973	-4	
OE-2306	299791	-3		OE-2807	299957	-2		OE-2846	299974	-2	
OE-2307	299791	-4		OE-2808	299957	-5		OE-2847	299974	-3	
OE-2308	299791	-6		OE-2809	299977	-4		OE-2848	299973	-5	
OE-2309	299791	-7		OE-2810	299957	-3		OE-2849	299973	-2	
OE-2310	299785	Ass'y		OE-2811	299977	-3		OE-2850	299973	-3	
OE-2311	299792	Ass'y		OE-2812	299976	-1		OE-2862	299953	-5	
OE-2312	299796	Ass'y		OE-2813	299978	-1		OE-2900	299837	-3	
OE-2313	299787	Ass'y		OE-2814	299976	-2		OE-2901	299835	Ass'y	
OE-2314	299792	Ass'y		OE-2815	299977	-1		OE-2902	299836	Ass'y	
OE-2315	299743	Ass'y		OE-2816	299978	-2		OE-2903	299832	Ass'y	
OE-2316	299810	Ass'y		OE-2817	299953	-1		OE-2904	299831	-1	

CROSS INDEX TO OE—DRAWING NUMBERS

OE NUMBER	BUREAU OF ORDNANCE			OE NUMBER	BUREAU OF ORDNANCE			OE NUMBER	BUREAU OF ORDNANCE		
	DRAWING No.	PC. No.	PAGE No.		DRAWING No.	PC. No.	PAGE No.		DRAWING No.	PC. No.	PAGE No.
OE-2906	299833	Ass'y		OE-2957	299871	-1		OE-3002	OS-4358		
OE-2907	299837	Ass'y		OE-2958	299871	-2		OE-3004	OS-52-6-18		
OE-2908	299838	Ass'y		OE-2959	299871	-3		OE-3005	299881	-1	
OE-2909	299834	Ass'y		OE-2960	299871	-4		OE-3006	299903	-1	
OE-2910	299834	Ass'y		OE-2961	299873	-1		OE-3007	OS-646		
OE-2911	299840	-2		OE-2962	299874	-1		OE-3008	P-27-B-2		
OE-2912	299839	-1		OE-2963	299873	-3		OE-3017	299903	-2	
OE-2913	299846	-2		OE-2964	299872	-1		OE-3018	OP-826		Ordn. Pamphlet
OE-2914	299839	-3		OE-2965	299873	-2		OE-3019	299960	-1	
OE-2915	299841	Ass'y		OE-2966	299873	-4		OE-3022	OS-627		
OE-2916	299855	-3		OE-2967	299872	List		OE-3030	299953	-4	
OE-2917	299842	Ass'y		OE-2968	299872	List		OE-3100	299834	-2	
OE-2918	299843	Ass'y		OE-2969	299880	Ass'y		OE-3101	299834	-1	
OE-2919	299844	Ass'y		OE-2970	299875	Ass'y		OE-3102	299834	-3	
OE-2920	299845	Ass'y		OE-2971	299876	-1		OE-3103	299847	-2	
OE-2921	299846	-1		OE-2972	299879	-1		OE-3104	299847	-4	
OE-2922	299847	Ass'y		OE-2973	299879	-2		OE-3105	299836	-1	
OE-2923	299839	-2		OE-2974	299877	-1		OE-3106	299853	-3	
OE-2924	299840	-1		OE-2975	299878	-1		OE-3107	299853	-1	
OE-2925	299849	Ass'y		OE-2976	299879	-3		OE-3108	299853	-2	
OE-2926	299852	-3		OE-2977	299880	-2		OE-3109	299854	-1	
OE-2927	299851	Ass'y		OE-2978	299880	-1		OE-3110	299847	-1	
OE-2928	299853	Ass'y		OE-2979	299868	Ass'y		OE-3111	299848	-1	
OE-2929	299854	Ass'y		OE-2980	299863	Ass'y		OE-3112	299848	-2	
OE-2931	299856	Ass'y		OE-2981	299864	-1		OE-3113	299849	-3	
OE-2933	299972	List		OE-2982	299867	-1		OE-3114	299849	-1	
OE-2936	299978	List		OE-2983	299867	-2		OE-3115	299850	-1	
OE-2937	300035	List		OE-2984	299865	-1		OE-3116	299850	-2	
OE-2941	299903	List		OE-2985	299866	-1		OE-3117	299833	-2	
OE-2942	299892	List		OE-2986	299867	-3		OE-3118	299833	-1	
OE-2944	299718	List		OE-2987	299868	-2		OE-3119	299837	-2	
OE-2945	299712	List		OE-2988	299868	-1		OE-3120	299837	-1	
OE-2946	299890 299891	-1		OE-2989	299975	Ass'y		OE-3121	299838	-3	
OE-2947	299889	-1		OE-2993	299872	List		OE-3122	299838	-2	
OE-2952	299892	-1		OE-2994	299872	List		OE-3123	299838	-1	
OE-2955	299869	Ass'y		OE-2995	299971	Ass'y		OE-3124	299838	-4	
OE-2956	299870	-1		OE-3000	OS-4354			OE-3125	299836	-2	
				OE-3001	OS-4357						

CROSS INDEX TO OE—DRAWING NUMBERS

OE NUMBER	BUREAU OF ORDNANCE			OE NUMBER	BUREAU OF ORDNANCE			OE NUMBER	BUREAU OF ORDNANCE		
	DRAWING No.	PC. No.	PAGE No.		DRAWING No.	PC. No.	PAGE No.		DRAWING No.	PC. No.	PAGE No.
OE-3126	299836	-3		OE-3164	299860	-1		OE-3516	299968	-2	
OE-3127	299836	-4		OE-3165	299857	-3		OE-3517	299968	-4	
OE-3128	299849	-2		OE-3166	299857	-1		OE-3518	299969	-2	
OE-3129	299848	-3		OE-3167	299857	-2		OE-3519	299968	-3	
OE-3130	299851	-1		OE-3168	299859	Ass'y		OE-3520	299967	-1	
OE-3131	299851	-2		OE-3169	299859	-1		OE-3521	299969	-4	
OE-3132	299852	-1		OE-3170	299858	-4		OE-3522	299966	-6	
OE-3133	299852	-2		OE-3171	299858	-3		OE-3523	299968	-1	
OE-3134	299843	-2		OE-3172	299861	Ass'y		OE-3524	299969	-1	
OE-3135	299843	-1		OE-3173	299861	-2		OE-3525	299962	-4	
OE-3136	299832	-2		OE-3174	299861	-1		OE-3526	299969	-3	
OE-3137	299832	-3		OE-3175	299861	-3		OE-3527	299965	-1	
OE-3138	299832	-4		OE-3176	299860	Ass'y		OE-3528	299965	-2	
OE-3139	299842	-1		OE-3177	299860	-3		OE-3529	299969	-5	
OE-3140	299842	-2		OE-3178	299860	-2		OE-3530	299970	Ass'y	208
OE-3141	299842	-3		OE-3179	299858	-2		OE-3531	299970	-1	208
OE-3142	299841	-2		OE-3180	299862	Ass'y		OE-3532	299970	-2	208
OE-3143	299841	-3		OE-3181	299862	-4		OE-3534	299965	-3	
OE-3144	299841	-4		OE-3182	299862	-2		OE-3535	299951	-2	
OE-3145	299835	-1		OE-3183	299862	-5		OE-3542	299884	Ass'y	208
OE-3146	299835	-4		OE-3184	299862	-1		OE-3544	299885	-1	208
OE-3147	299835	-2		OE-3185	299862	-3		OE-3545	299886	-1	208
OE-3148	299835	-3		OE-3500	299959 299960	Ass'y		OE-3548	299888	-2	209
OE-3149	299835	-5		OE-3501	299961	-1		OE-3549	299885	-2	208
OE-3150	299845	-1		OE-3502	299962	-1		OE-3550	299885	-3	208
OE-3151	299845	-2		OE-3503	299964	-1		OE-3551	299885	-4	208
OE-3152	299854	-2		OE-3504	299963	-1		OE-3552	299886	-2	208
OE-3153	299854	-4		OE-3505	299962	-2		OE-3553	299886	-3	208
OE-3154	299855	-2		OE-3506	299962	-3		OE-3554	299886	-4	208
OE-3155	299855	-1		OE-3507	299963	-2		OE-3555	299887	-3	208
OE-3156	299854	-3		OE-3508	299966	List		OE-3556	299888	-1	209
OE-3157	299831	Ass'y		OE-3510	299962	List		OE-3557	299888	-4	209
OE-3158	299831	-2		OE-3511	299966	-3		OE-3558	299888	-5	209
OE-3159	299831	-3		OE-3512	299966	-2		OE-3559	299888	-6	209
OE-3160	299844	-1		OE-3513	299966	-4		OE-3560	299888	-3	209
OE-3161	299844	-2		OE-3514	299966	-5		OE-3561	299887	Ass'y	209
OE-3162	299857	Ass'y		OE-3515	299966	-1		OE-3563	299887	-2	
OE-3163	299858	-1						OE-3565	299887	-1	

CROSS INDEX TO ORDNANCE DRAWING NUMBERS

BUREAU OF ORDNANCE			OE NUMBER	BUREAU OF ORDNANCE			OE NUMBER	BUREAU OF ORDNANCE			OE NUMBER
DRAWING No.	PC. No.	PAGE No.		DRAWING No.	PC. No.	PAGE No.		DRAWING No.	PC. No.	PAGE No.	
294317	-1		OE-2219	299667	-3	166	OE-1325	299676	-4	167	OE-1267
	-2		OE-2290	299668	-1	166	OE-1320		-5	166	OE-1056
	-3		OE-2289		-2	166	OE-1321		-6	167	OE-1073
299650	-1	163	OE-1010	299669	Ass'y		OE-1031	299677	Ass'y	170	OE-1033
299650	-2		OE-1010-FP	299670	-1	166	OE-1040		-1	170	OE-1064
299651	Ass'y	164	OE-1301	299671	Ass'y		OE-1029		-2	170	OE-1060
299651	Ass'y	164	OE-1303		-1	169	OE-1072	299678	Ass'y	168	OE-1035
	-1	164	OE-1305		-2	169	OE-1331		-1	168	OE-1250
	-2	164	OE-1306		-3	169	OE-1059		-2	168	OE-1077
299652	-1	164	OE-1304		-4	174	OE-1263		-3	168	OE-1076
299653	-1	164	OE-1307		-5	169	OE-1052		-4	167	OE-1057
	-2	164	OE-1309		-6		OE-1083		-5	167	OE-1327
299654	-1	164	OE-1308		-7		OE-1084	299679	-1	168	OE-1043
299655	Ass'y	164	OE-1312		-8		OE-1085		-2	168	OE-1046
	-1	164	OE-1253	299672	Ass'y	169	OE-1039	299680	Ass'y		OE-1034
	-2	164	OE-1048		-1	169	OE-1049	299680	Ass'y		OE-1037
299656	-1	164	OE-1310		-2	169	OE-1050		-1	167	OE-1066
299657	Ass'y	164	OE-1313		-3	169	OE-1270		-2	168	OE-1067
	-1	165	OE-1254		-4	169	OE-1345		-3	167	OE-1330
	-2	165	OE-1044		-5	169	OE-1051		-4	167	OE-1074
	-3	165	OE-1047		-6	169	OE-1265		-5	167	OE-1261
299658	-1	165	OE-1311	299673	-1	168	OE-1078		-6	168	OE-1075
	-2		OE-1311		-2	168	OE-1079	299681	-1	167	OE-1045
299659	Ass'y		OE-1302		-3	168	OE-1070		-2	168	OE-1340
	-1	165	OE-1103		-4	169	OE-1339	299682	-1		OE-1061
	-2	165	OE-1104	299674	-1	170	OE-1054	299683	Ass'y	171	OE-1038
	-3	166	OE-1322		-2	170	OE-1071		-2	171	OE-1062
299659	-4	166	OE-1329		-3	170	OE-1336		-3	171	OE-1068
299660	-1	165	OE-1315		-4	169	OE-1030		-4	171	OE-1065
299665	-1	165	OE-1317		-5	170	OE-1053		-5	171	OE-1335
	-2	165	OE-1319	299675	-1	170	OE-1063		-6	171	OE-1258
	-3	165	OE-1341		-2	170	OE-1055	299684	Ass'y		OE-1248
	-4	165	OE-1346		-3	170	OE-1081	299684	Ass'y	171	OE-1245
299666	-1	165	OE-1316		-4	170	OE-1069		-1	171	OE-1215
	-2	166	OE-1323		-5	170	OE-1344		-2	172	OE-1343
	-3	166	OE-1324	299676	-1	167	OE-1058		-3	171	OE-1238
299667	-1	166	OE-1102		-2	167	OE-1337	299685	-1	171	OE-1202
	-2	166	OE-1318		-3	167	OE-1269	299686	-1	171	OE-1216

CROSS INDEX TO ORDNANCE DRAWING NUMBERS

BUREAU OF ORDNANCE			OE NUMBER	BUREAU OF ORDNANCE			OE NUMBER	BUREAU OF ORDNANCE			OE NUMBER
DRAWING No.	PC. No.	PAGE No.		DRAWING No.	PC. No.	PAGE No.		DRAWING No.	PC. No.	PAGE No.	
299686	-2	171	OE-1217	299694	-1		OE-1285	299704	-1	190	OE-1174
	-3	176	OE-1230	299695	-1		OE-1286		-2	191	OE-1194
	-4	176	OE-1224		-2	175	OE-1236		-3	191	OE-1195
299687	Ass'y	172	OE-1247		-3	175	OE-1234		-4	191	OE-1278
	-1	172	OE-1211		-4		OE-1287		-5	191	OE-1277
	-2	173	OE-1212		-5	175	OE-1262		-6	189	OE-1187
	-3	173	OE-1213		-6	172	OE-1201		-7	192	OE-1189
	-4	173	OE-1342	299696	Ass'y	175	OE-1244		-8	188	OE-1192
299688	Ass'y	171	OE-1279		-1	175	OE-1328	299705	-1	192	OE-1198
	-1	173	OE-1334		-2	175	OE-1237		-2	192	OE-1180
	-2	173	OE-1214		-3	175	OE-1235		-3	188	OE-1191
	-3	173	OE-1266	299697	Ass'y	174	OE-1341		-4		OE-1199
	-4	173	OE-1268		-1	174	OE-1229		-5		OE-2282
					-2	174	OE-1227		-6	188	OE-1190
299689	Ass'y	172	OE-1200 OE-1240		-3	174	OE-1257		-7		OE-1199
	-1	172	OE-1206		-4	174	OE-1333	299706	Ass'y	197	OE-1530
	-2	172	OE-1204		-5	174	OE-1228	299707	Ass'y	197	OE-1531
299690	-1	172	OE-1203		-6	176	OE-1326	299708	-1	197	OE-1537
	-2	172	OE-1209	299698	-1	175	OE-1223		-2	197	OE-1547
	-3	177	OE-1207		-2	174	OE-1218		-3	197	OE-1539
	-4	172	OE-1205		-3	176	OE-1220		-4	197	OE-1540
	-5	172	OE-1256		-4	176	OE-1221	299709	-1	197	OE-1541
	-6	177	OE-1208	299699	Ass'y		OE-1170		-2	197	OE-1545
	-7	177	OE-1272	299699		188	OE-1166	299710	Ass'y	197	OE-1532
	-8	172	OE-1210	299700	-1	188	OE-1171	299711	-1	197	OE-1538
299691	Ass'y	173	OE 1246	299701	-1	189	OE-1175	299712	List		OE-2945
	-1	173	OE 1231		-2	190	OE-1185		-1	197	OE-1543
	-2	173	OE 1223		-3	189	OE-1186		-2	197	OE-1542
	-3	173	OE-1332		-4	190	OE-1173		-3	197	OE-1546
299692	Ass'y	174	OE-1242		-5	191	OE-1282		-4	198	OE-1528
	-1	173	OE-1219	299702	Ass'y	191	OE-1193		-5	198	OE-1296
	-2	174	OE-1225	299702	Ass'y	191	OE-1168	299713	Ass'y	198	OE-1534
	-3	174	OE-1226		-1	191	OE-1271		-1	198	OE-1553
	-4	174	OE-1338		-2	191	OE-1196		-2	198	OE-1554
	-5	174	OE-1255		-3	191	OE-1197		-3	198	OE-1555
	-6	173	OE-1232		-4	192	OE-1176	299714	Ass'y	198	OE-1600
299693	Ass'y	175	OE-1243		-5	188	OE-1260		-1	199	OE-1294
299694	Ass'y	175	OE-1284	299703	-1	190	OE-1167		-2	198	OE-1584

CROSS INDEX TO ORDNANCE DRAWING NUMBERS

BUREAU OF ORDNANCE			OE NUMBER	BUREAU OF ORDNANCE			OE NUMBER	BUREAU OF ORDNANCE			OE NUMBER
DRAWING No.	Pc. No.	PAGE No.		DRAWING No.	Pc. No.	PAGE No.		DRAWING No.	Pc. No.	PAGE No.	
299715	-1	198	OE-1549	299723	-4	201	OE-1293	299734	Ass'y	180	OE-1495
299716	Ass'y		OE-1601	299724	-1	201	OE-1544		-1		OE-1524
	-1		OE-1571		-2	201	OE-1556		-2		OE-1525
	-2		OE-1570		-3		OE-1557	299735	-1	180	OE-1522
299717	Ass'y	202	OE-1535		-4		OE-1558		-2	180	OE-1523
	-1	202	OE-1527		-5	201	OE-1291	299736	Ass'y	171	OE-1036
	-2	202	OE-1536	299725	-1	200	OE-1548		-1		OE-1503
	-3	202	OE-1590	299726	-1	200	OE-1560		-2		OE-1526
299718	List		OE-2944		-2	203	OE-1578		-3		OE-1283
	-1	202	OE-1589		-3	203	OE-1594		-4		OE-1494
	-2	202	OE-1588		-4	203	OE-1580		-5		OE-1082
	-3	202	OE-1290		-5	203	OE-1595	299737	Ass'y		OE-1496
	-4	202	OE-1596		-6	203	OE-1292		-1	178	OE-1514
	-5	202	OE-1598		-7	201	OE-1583	299738	Ass'y	178	OE-1490
299719	Ass'y	198	OE-1533		-8	201	OE-1529	299738	Ass'y	178	OE-1491
	-1	198	OE-1552		-9	201	OE-1575		-1		OE-1515
	-2	198	OE-1550	299727	-1	202	OE-1585		-2		OE-1492
	-3	198	OE-1551		-2	202	OE-1587	299739	-1	178	OE-1493
	-4	199	OE-1561		-3	200	OE-1568		-2		OE-1518
299720	-1	200	OE-1567		-4	200	OE-1295		-3	178	OE-1517
	-2	200	OE-1562		-5	200	OE-1569		-4	178	OE-1507
	-3	199	OE-1599		-6	200	OE-1574		-5	179	OE-1509
	-4	199	OE-1573		-7	200	OE-1593		-6	179	OE-1508
299721	-1	199	OE-1579		-8	200	OE-1298	299740	-1	179	OE-1274
	-2	199	OE-1563	299728	-1	206	OE-1591		-2	179	OE-1521
	-3	203	OE-1577	299729	Ass'y		OE-1500		-3	180	OE-1511
	-4	203	OE-1576	299730	Ass'y	178	OE-1497		-4	180	OE-1510
	-5	199	OE-1564		-1		OE-1519		-5	180	OE-1512
	-6	199	OE-1566		-2		OE-1513		-6	179	OE-1281
	-7	199	OE-1297	299731	Ass'y	178	OE-1499	299741	Ass'y		OE-2000
	-8	199	OE-1565	299731	Ass'y		OE-1501	299742	-1		OE-2010
	-9	Op. with Pc. 1	OE-1579		-1		OE-1506	299743	Ass'y		OE-2315
299722	-1		OE-1572	299732	-1		OE-1504	299744	-1		OE-2060
	-2	201	OE-1582		-2		OE-1502	299745	-1		OE-2055
299723	-1	201	OE-1581		-3		OE-1520		-2		OE-2240
	-2	201	OE-1586	299733	Ass'y	179	OE-1498		-3		OE-2046
	-3	201	OE-1559		-1		OE-1516		-4		OE-2049
					-2		OE-1505		-5		OE-2047

CROSS INDEX TO ORDNANCE DRAWING NUMBERS

BUREAU OF ORDNANCE			OE NUMBER	BUREAU OF ORDNANCE			OE NUMBER	BUREAU OF ORDNANCE			OE NUMBER
DRAWING No.	PC. No.	PAGE No.		DRAWING No.	PC. No.	PAGE No.		DRAWING No.	PC. No.	PAGE No.	
	-6		OE-2048	299757	-2		OE-2244	299767	-2		OE-2117
299746	-1		OE-2105		-3		OE-2066		-3		OE-2118
	-2		OE-2241		-4		OE-2068	299770	Ass'y		OE-2091
299747	Ass'y		OE-2040		-5		OE-2064		-2		OE-2120
	-1		OE-2041	299758	Ass'y		OE-2006		-3		OE-2115
	-2		OE-2042		-1		OE-2083		-4		OE-2234
	-3		OE-2043		-2		OE-2065		-5		OE-2121
	-4		OE-2242		-3		OE-2063		-6		OE-2109
299748	Ass'y		OE-2086	299759	-1		OE-2062	299771	-1		OE-2111
	-1		OE-2038		-2		OE-2081		-2		OE-2257
	-2		OE-2039		-3		OE-2067		-3		OE-2235
	-3		OE-2045		-4		OE-2097		-4		OE-2119
	-4		OE-2037	299760	Ass'y		OE-2005		-5		OE-2099
299749	Ass'y		OE-2004		-1		OE-2012		-6		OE-2304
	-1		OE-2013	299761	-1		OE-2016		-7		OE-2305
	-2		OE-2151	299762	Ass'y		OE-2089	299772	-1		OE-2011
299750	Ass'y		OE-2003		-1		OE-2247		-2		OE-2255
	-1		OE-2143		-2		OE-2085		-3		OE-2273
	-2		OE-2014		-3		OE-2090	299773	-1		OE-2294
299751	-1		OE-2155		-4		OE-2134		-2		OE-2295
	-2		OE-2017	299763	-1		OE-2033		-3		OE-2296
	-3		OE-2233	299764	-1		OE-2112		-4		OE-2077
	-4		OE-2250	299765	-1		OE-2107		-5		OE-2283
	-5		OE-2015	299766	-1		OE-2057	299774	Ass'y		OE-2101
	-6		OE-2152		-2		OE-2239	299775	Ass'y		OE-2102
299752	-1		OE-2079		-3		OE-2254	299776	-1		OE-2104
299753	Ass'y		OE-2088		-4		OE-2054	299777	Ass'y		OE-2087
	-1		OE-2114	299767	-1		OE-2129		-1		OE-2127
299754	-1		OE-2080		-2		OE-2251		-2		OE-2243
299755	-1		OE-2126		-3		OE-2106		-3		OE-2108
	-2		OE-2056		-4		OE-2093		-4		OE-2128
	-3		OE-2116	299768	-1		OE-2035	299778	Ass'y		OE-2103
	-4		OE-2236		-2		OE-2094		-1		OE-2139
	-5		OE-2238		-3		OE-2075		-2		OE-2302
299756	Ass'y		OE-2001		-4		OE-2076		-3		OE-2138
299756	Ass'y		OE-2002		-5		OE-2084		-4		OE-2258
299757	Ass'y		OE-2007	299769	Ass'y		OE-2100		-5		OE-2135
	-1		OE-2082		-1		OE-2098		-6		OE-2125

CROSS INDEX TO ORDNANCE DRAWING NUMBERS

BUREAU OF ORDNANCE			OE NUMBER	BUREAU OF ORDNANCE			OE NUMBER	BUREAU OF ORDNANCE			OE NUMBER
DRAWING No.	PC. No.	PAGE No.		DRAWING No.	PC. No.	PAGE No.		DRAWING No.	PC. No.	PAGE No.	
299779	-1		OE-2110	299787	-1		OE-2061	299796	Ass'y		OE-2312
299780	-1		OE-2274		-2		OE-2002	299796	Ass'y		OE-2157
	-2		OE-2123		-3		OE-2034		-1		OE-2164
	-3		OE-2051		-4		OE-2036		-2		OE-2166
	-4		OE-2050		-5		OE-2073	299797	-1		OE-2167
	-5		OE-2053	299788	-1		OE-2153		-2		OE-2168
	-6		OE-2246		-2		OE-2165		-3		OE-2278
299781	-1		OE-2245		-3		OE-2256		-4		OE-2169
	-2		OE-2142		-4		OE-2248		-5		OE-2163
	-3		OE-2136		-5		OE-2260		-6		OE-2268
	-4		OE-2137		-6		OE-2249	299798	-1		OE-2160
	-5		OE-2253	299789	-1		OE-2030		-2		OE-2161
	-6		OE-2286	299790	-1		OE-2032		-3		OE-2162
	-7		OE-2285		-2		OE-2069		-4		OE-2191
	-8		OE-2287		-3		OE-2277		-5		OE-2269
299782	Ass'y		OE-2149		-4		OE-2078	299799	Ass'y		OE-2207
	-1	209	OE-2029	299791	-1		OE-2031		-1		OE-2176
299783	-1		OE-2146		-2		OE-2095		-2		OE-2279
	-2		OE-2147		-3		OE-2306		-3		OE-2170
	-3		OE-2148		-4		OE-2307	299800	-1		OE-2179
	-4		OE-2297		-5		OE-2096		-2		OE-2177
	-5		OE-2298		-6		OE-2308		-3		OE-2178
	-6		OE-2284		-7		OE-2309		-5		OE-2340
299784	-1		OE-2212		-8		OE-2300		-6		OE-2185
	-2		OE-2213	299792	Ass'y		OE-2311		-7		OE-2301
	-3		OE-2393	299792	Ass'y		OE-2314	299801	Ass'y		OE-2198
	-4		OE-2288		-1		OE-2159		-1		OE-2206
	-5		OE-2321	299793	-1		OE-2158		-2		OE-2265
299785	Ass'y		OE-2310	299794	Ass'y		OE-2205	299802	Ass'y		OE-2187
299786	Ass'y		OE-2009		-1		OE-2188	299803	-1		OE-2192
299786	Ass'y		OE-2008		-2		OE-2190		-2		OE-2196
	-1		OE-2070		-3		OE-2189		-3		OE-2197
	-2		OE-2072		-4		OE-2262		-4		OE-2199
	-3		OE-2074		-5		OE-2261		-5		OE-2201
	-4		OE-2140	12-Z-339 #7			OE-2259		-6		OE-2202
	-5		OE-2071	299795	-1		OE-2174		-7		OE-2200
	-6		OE-2141		-2		OE-2175		-8		OE-2280
299787	Ass'y		OE-2313		-3		OE-2263	299804	-1		OE-2193

CROSS INDEX TO ORDNANCE DRAWING NUMBERS

BUREAU OF ORDNANCE			OE NUMBER	BUREAU OF ORDNANCE			OE NUMBER	BUREAU OF ORDNANCE			OE NUMBER
DRAWING No.	PC. No.	PAGE No.		DRAWING No.	PC. No.	PAGE No.		DRAWING No.	PC. No.	PAGE No.	
299804	-2		OE-2194	299813	-4		OE-2227	299822	Ass'y	188	OE-1163
	-3		OE-2144		-5		OE-2229		-1	189	OE-1162
	-4		OE-2184		-6		OE-2228	299823	-1	188	OE-1161
	-5		OE-2180	299814	List		OE-1603	299824	Ass'y		OE-1030
299805	-1		OE-2210		-1	206	OE-1617	299824	Ass'y		OE-1032
	-2		OE-2291		-2	207	OE-1618	299825	Ass'y		OE-1000 SHEET 1
	-3		OE-2292		-3	204	OE-1621				
	-4		OE-2195		-4	204	OE-1606	299826	Ass'y		OE-1000 SHEET 2
	-5		OE-2211	299815	Ass'y	204	OE-1622				
	-6		OE-2181		-1	204	OE-1619	299827	Ass'y	163	OE-1001
	-7		OE-2154		-2		OE-1623		-1	163	OE-1011
299806	Ass'y		OE-2203		-3		OE-1624		-2	163	OE-1012
	-1		OE-2183		-4		OE-1625		-3		OE-1011-SC
	-2		OE-2267		-5		OE-1626	299828	-1	175	OE-1233
299807	Ass'y		OE-2319	299816	-1		OE-1630	299829	-1	175	OE-1249
299807	Ass'y		OE-2204		-2		OE-1631	299830	Ass'y		OE-1638
	-1		OE-2182		-3		OE-1633		-1		OE-1639
	-2		OE-2145		-4	204	OE-1634		-2		OE-1640
	-3		OE-2186	299817	-1		OE-1632		-3		OE-1643
299808	Ass'y		OE-2318		-2	204	OE-1620		-4		OE-1641
299808	Ass'y		OE-2320		-3	205	OE-1607		-5		OE-1642
299808	Ass'y		OE-2171		-4	205	OE-1616	299831	Ass'y		OE-3157
	-1		OE-2133	299818	-1	206	OE-1627	299831	-1		OE-2904
	-2		OE-2132		-2	206	OE-1628	299831	-2		OE-3158
299809	-1		OE-2303		-3	205	OE-1612	299831	-3		OE-3159
	-2		OE-2173		-4		OE-1611	299832	Ass'y		OE-2903
	-3		OE-2172		-5	204	OE-1608		-1		OE-1637
299810	Ass'y		OE-2316		-6	205	OE-1609		-2		OE-3136
299810	Ass'y		OE-2317		-7	205	OE-1613		-3		OE-3137
299811	Ass'y		OE-2220		-8	205	OE-1615		-4		OE-3138
299811	Ass'y		OE-2221	299819	-1	205	OE-1635	299833	Ass'y		OE-2906
	-1		OE-2224		-2	205	OE-1614		-1		OE-3118
	-2		OE-2225		-3	205	OE-1610		-2		OE-3117
299812	-1		OE-2222		-4	205	OE-1629	299834	Ass'y		OE-2909
	-2		OE-2223		-5	204	OE-1605	299834	Ass'y		OE-2910
299813	-1		OE-2226		-6	206	OE-1636		-1		OE-3101
	-2		OE-2218	299820	-1		OE-1604		-2		OE-3100
	-3		OE-2217	299821	Ass'y		OE-1160		-3		OE-3102

CROSS INDEX TO ORDNANCE DRAWING NUMBERS

BUREAU OF ORDNANCE			OE NUMBER	BUREAU OF ORDNANCE			OE NUMBER	BUREAU OF ORDNANCE			OE NUMBER
DRAWING No.	PC. No.	PAGE No.		DRAWING No.	PC. No.	PAGE No.		DRAWING No.	PC. No.	PAGE No.	
299835	Ass'y		OE-2901	299844	-1		OE-3160	299856	Ass'y		OE-2931
	-1		OE-3145		-2		OE-3161	299857	Ass'y		OE-3162
	-2		OE-3147	299845	Ass'y		OE-2920		-1		OE-3166
	-3		OE-3148		-1		OE-3150		-2		OE-3167
	-4		OE-31461		-2		OE-3151		-3		OE-3165
	-5		OE-3149	299846	-1		OE-2921	299858	-1		OE-3163
299836	Ass'y		OE-2902		-2		OE-2913		-2		OE-3179
	-1		OE-3105	299847	Ass'y		OE-2922		-3		OE-3171
	-2		OE-3125		-1		OE-3110		-4		OE-3170
	-3		OE-3126		-2		OE-3103	299859	Ass'y		OE-3168
	-4		OE-3127		-4		OE-3104		-1		OE-3169
299837	Ass'y		OE-2907	299848	-1		OE-3111	299860	Ass'y		OE-3176
	-1		OE-3120		-2		OE-3112		-1		OE-3164
	-2		OE-3119		-3		OE-3120		-2		OE-3178
	-3		OE-2900	299849	Ass'y		OE-2925		-3		OE-3177
299838	Ass'y		OE-2908		-1		OE-3114	299861	Ass'y		OE-3172
	-1		OE-3123		-2		OE-3128		-1		OE-3174
	-2		OE-3122		-3		OE-3113		-2		OE-3173
	-3		OE-3121	299850	-1		OE-3115		-3		OE-3175
	-4		OE-3124		-2		OE-3116	299862	Ass'y		OE-3180
299839	-1		OE-2912	299851	Ass'y		OE-2927		-1		OE-3184
	-2		OE-2923		-1		OE-3130		-2		OE-3182
	-3		OE-2914		-2		OE-3131		-3		OE-3185
299840	-1		OE-2924	299852	-1		OE-3132		-4		OE-3181
	-2		OE-2911		-2		OE-3133		-5		OE-3183
					-3		OE-2926	299863	Ass'y		OE-2980
299841	Ass'y		OE-2915	299853	Ass'y		OE-2928	299864	-1		OE-2981
	-1		OE-2915		-1		OE-3107	299865	-1		OE-2984
	-2		OE-3142		-2		OE-3108	299866	-1		OE-2985
	-3		OE-3143		-3		OE-3106	299867	-1		OE-2982
	-4		OE-3144	299854	Ass'y		OE-2929		-2		OE-2983
299842	Ass'y		OE-2917		-1		OE-3109		-3		OE-2986
	-1		OE-3139		-2		OE-3152	299868	Ass'y		OE-2979
	-2		OE-3140		-3		OE-3156		-1		OE-2988
	-3		OE-3141		-4		OE-3153		-2		OE-2987
299843	Ass'y		OE-2918	299855	-1		OE-3155	299869	Ass'y		OE-2955
	-1		OE-3135		-2		OE-3154	299870	-1		OE-2956
	-2		OE-3134		-3		OE-2916	299871	-1		OE-2957

CROSS INDEX TO ORDNANCE DRAWING NUMBERS

BUREAU OF ORDNANCE			OE NUMBER	BUREAU OF ORDNANCE			OE NUMBER	BUREAU OF ORDNANCE			OE NUMBER
DRAWING No.	PC. No.	PAGE No.		DRAWING No.	PC. No.	PAGE No.		DRAWING No.	PC. No.	PAGE No.	
299871	-2		OE-2958		-1		OE-3565	299898	-1	183	OE-1724
	-3		OE-2959		-2		OE-3563		-2	183	OE-1725
	-4		OE-2960		-3		OE-3555		-3	183	OE-1723
299872	List		OE-2967	299888	-1		OE-3556		-4		OE-1722
299872	List		OE-2994		-2		OE-3548	299899	Ass'y	183	OE-1707
299872	List		OE-2968		-3		OE-3560		-1		OE-1721
299872	List		OE-2993		-4		OE-3557		-2	183	OE-1289
	-1		OE-2964		-5		OE-3558		-3	183	OE-1727
299873	-1		OE-2961		-6		OE-3559		-4	183	OE-1726
	-2		OE-2965	299889	-1		OE-2947	299900	Ass'y	181	OE-1704
	-3		OE-2963				OE-2946 SHEET 1		-1		OE-1715
	-4		OE-2966	299890	-1			299901	-1	163	OE-1013
299874	-1		OE-2962				OE-2946 SHEET 2	299902	Ass'y	163	OE-1003
299875	Ass'y		OE-2970	299891			OE-2942		-1	163	OE-1014
299876	-1		OE-2971	299892	List		OE-2833		-2	163	OE-1015
299877	-1		OE-2974	299892	List		OE-2952		-3	163	OE-1016
299878	-1		OE-2975		-1		OE-1700	299903	List		OE-2941
299879	-1		OE-2972	299893	Ass'y		OE-1703		-1		OE-3006
	-2		OE-2973	299894	Ass'y	181	OE-1716		-2		OE-3017
	-3		OE-2976		-1		OE-1711	299904	List		OE-2839
299880	Ass'y		OE-2969		-2	182	OE-1712	299906	-1		OE-1728
	-1		OE-2978		-3	182	OE-1714		List		OE-2840
	-2		OE-2977		-4	183	OE-1713	299918	Ass'y		OE-1359
299881	-1		OE-3005		-5	183	OE-1708		-1		OE-1360
299882	Ass'y		OE-1106	299895	Ass'y	182	OE-1729		-2		OE-1361
	-1		OE-1107		-1	182	OE-1730	12-Z-22 #253			OE-2271
	-2		OE-1108		-2	182	OE-1731	12-Z-22 #254			OE-2272
299883	Ass'y	166	OE-1105		-3	182	OE-1710	12-Z-22 #256			OE-2275
299884	Ass'y	208	OE-3542	299896	-1	182	OE-1701	12-Z-48 #12			OE-2230
299885	-1	208	OE-3544	299897	Ass'y	181	OE-1702	12-Z-48 #25			OE-2231
	-2	208	OE-3549	299897	Ass'y	181	OE-1717	12-Z-48 #40			OE-2232
	-3	208	OE-3550		-1	181	OE-1720	299951	-2		OE-3535
	-4	208	OE-3551		-2	181	OE-1718	299952	Ass'y		OE-2832
299886	-1	208	OE-3545		-3	181	OE-1288	299953	List		OE-2837
	-2	208	OE-3552		-4	181	OE-1719		-1		OE-2817
	-3	208	OE-3553		-5	182	OE-1705		-2		OE-2800
	-4	208	OE-3554	299898	Ass'y	183	OE-1706		-3		OE-2818
299887	Ass'y	209	OE-3561	299898	Ass'y	183			-4		OE-3030

CROSS INDEX TO ORDNANCE DRAWING NUMBERS

BUREAU OF ORDNANCE			OE NUMBER	BUREAU OF ORDNANCE			OE NUMBER	BUREAU OF ORDNANCE			OE NUMBER
DRAWING No.	PC. No.	PAGE No.		DRAWING No.	PC. No.	PAGE No.		DRAWING No.	PC. No.	PAGE No.	
299953	-5		OE-2862	299965	-1		OE-3527	299974	-3		OE-2847
299954	-1		OE-2819		-2		OE-3528	12-Z-22 #252			OE-2270
	-2		OE-2823		-3		OE-3534	299975	List		OE-2989
	-3		OE-2824	299966	List		OE-3508	299976	-1		OE-2812
299955	-1		OE-2820		-1		OE-3515		-2		OE-2814
	-1		OE-2822		-2		OE-3512	299977	-1		OE-2815
	-3		OE-2825		-3		OE-3511		-2		OE-2801
	-4		OE-2826		-4		OE-3513		-3		OE-2811
	-5		OE-2834		-5		OE-3514		-4		OE-2809
	-6		OE-2835		-6		OE-3522		-5		OE-2806
299956	Ass'y		OE-2827	299967	-1		OE-3520		-6		OE-2802
	-1		OE-2821	299968	-1		OE-3523	299978	List		OE-2936
	-2		OE-2829		-2		OE-3516		-1		OE-2813
	-3		OE-2828		-3		OE-3519		-2		OE-2816
	-4		OE-2830		-4		OE-3517	299983	Ass'y		OE-1733
299957	-1		OE-2804	299969	-1		OE-3524	299984	Ass'y		OE-1732
	-2		OE-2807		-2		OE-3518	300005	Ass'y	207	OE-2328
	-3		OE-2810		-3		OE-3526	300006	-1		OE-2329
	-4		OE-2803		-4		OE-3521		-2		OE-2330
	-5		OE-2808		-5		OE-3529		-3		OE-2331
	-6		OE-2805	299970	Ass'y	208	OE-3530	300007	-1		OE-2332
299958	-1		OE-2836		-1	208	OE-3531		-2		OE-2333
299959	Ass'y		OE-3500		-2	208	OE-3532		-3		OE-2334
299960	Ass'y		OE-3500	299971	Ass'y		OE-2995	300008	-1		OE-2335
	-1		OE-3019	299972	List		OE-2933		-2		OE-2336
299961	-1		OE-3501		-1		OE-2841		-3		OE-2337
299962	List		OE-3510		-2		OE-2844		-4		OE-2341
	-1		OE-3502	299973	-1		OE-2943		-5		OE-2342
	-2		OE-3505		-2		OE-2849	300009	List		OE-2831
	-3		OE-3506		-3		OE-2850	300010	-1		OE-2325
	-4		OE-3525		-4		OE-2845	300026	-1		OE-2322
299963	-1		OE-3504		-5		OE-2848	300035	List		OE-2937
	-2		OE-3507	299974	-1		OE-2842				
299964	-1		OE-3503		-2		OE-2846				

SAFETY PRECAUTIONS

1. See that the top of the barrel locking lever is flush with the breech casing. See that the barrel is fully seated.
(Failure to comply has resulted in barrels being blown out of the gun, and injuries to personnel.)
2. See that the magazine is properly tensioned.
(A fully loaded magazine is properly tensioned only when the spring axis has been rotated against the positive stop. See NavOrd OCL G31-44.)
3. Make sure that the double loading stop plunger and retaining pin are in place in the barrel.
(Loss of the plunger while changing barrels has resulted in ruptured cases and escape of burning gases through the plunger hole.)
4. Check the parallelogram linkage for proper assembly.
(Incorrect assembly can cause a "runaway gun". See OTI G12-44.)
5. When a stoppage occurs, be sure to follow the procedure of OP 1591, Clearing of Live Ammunition from Guns.

20 MM A.A. GUN

20 mm Machine Gun Mechanisms, Marks 2 and 4
20 mm Gun Barrels, Marks 2, 3, 4, and 4 Mod. 1
20 mm Sights, Marks 2, 4, 4 Mod. 1, and 5
20 mm Magazines, Marks 2 and 4
20 mm Shoulder Rests, Marks 2, 4, 5, and 5 Mod. 1

O.P. 911 is changed as follows:

The purpose of this addendum is to amplify the instructions contained in O.P. 911, and to describe new tools and methods intended to increase the efficiency and safety of operation of the 20 mm A.A. gun. The following items are covered herein:

- (a) Breech Face Piece Tool
- (b) Auxiliary Handle for Magazine
- (c) Magazine Casualty
- (d) Cocking Index Line
- (e) Plugging of Holes in Shield Plates
- (f) Parallelogram Assembly
- (g) Permanent Set of Barrel Springs
- (h) Safety Handles for Ejector Rod Assembly
- (i) Spring for Barrel Bore Inspection Mirror
- (j) Hammer Plate Securing Spring
- (k) Breech Face Piece
- (l) Cotter Pins for Trigger and Barrel Locking Lever

(a) BREECH FACE PIECE TOOL

Figure 1 has been approved for production and will be furnished in the tool rolls of new guns. For guns now in service, the tool of Figure 1 may be made up by any activity that considers it desirable. A number of similar tools have been submitted by the Fleet. In one case, a common file handle was used as a grip for the tool. In another design, one end of a rod was pointed in a manner similar to that shown in Figure 1 and the other end was formed into a loop to serve as an integral handle. Any of these methods may be employed, provided that the pointed end of the tool conforms generally to that shown in Figure 1.

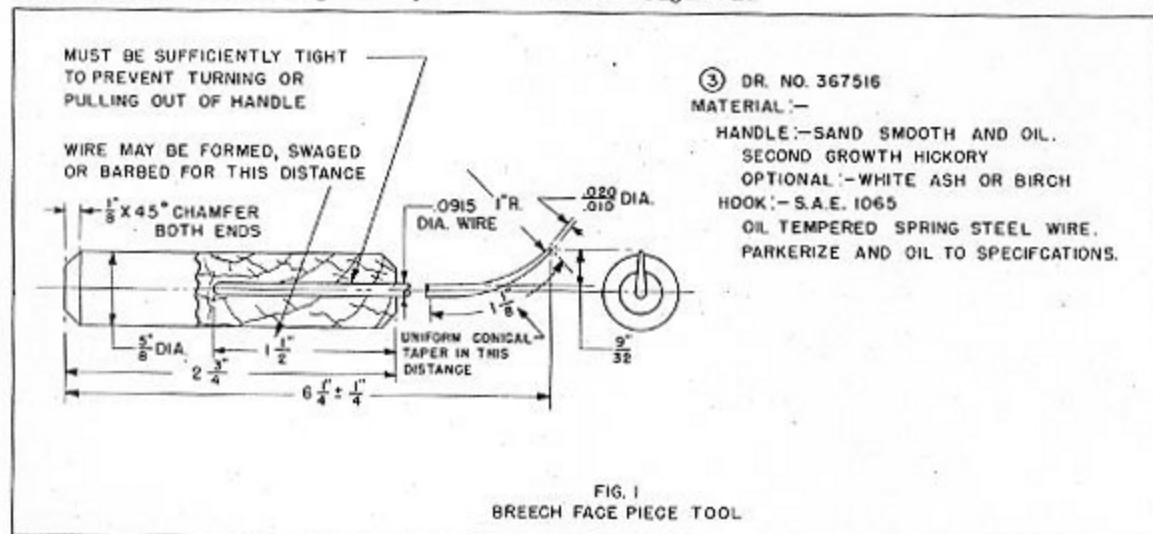

(b) AUXILIARY HANDLE FOR MAGAZINE

Difficulties have been encountered in removing 20 mm magazines from Type X ready service stowage chests similar to NYD Norfolk Sk. No. 47237 (HuOrd. Dr. No. 332979) - 20 mm Ready Service Ammunition Chest. In this type of chest, the magazines are racked with their axes horizontal, and the handles are not readily accessible through the opening at the top of the chest.

Figure 2 shows an auxiliary handle that has been developed to aid in lifting magazines from chests of this type. The handle is fastened to the magazine by the two casing bolts which are on top when the magazine is stowed. The handle is not available for distribution to the service but may be manufactured and used by any activity that so desires.

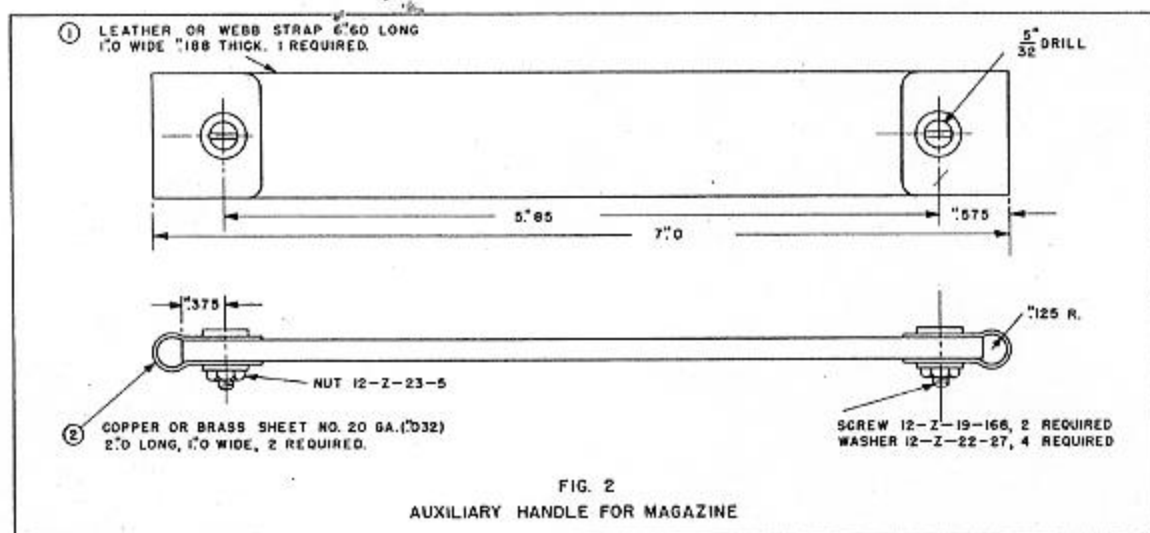

(c) MAGAZINE CASUALTY

A casualty has occurred in service wherein a cartridge in the magazine mouthpiece was fired while the magazine was being shipped. The forward guide lugs on the magazine were not pushed all the way forward and the rear part of the mouthpiece struck and tripped the magazine catch (299679-2), allowing the ejector (299681-1) to move forward. The toe of the interlock lever (299680-4) then struck the primer of the cartridge in the mouthpiece, igniting the propellant. In order to prevent a recurrence of this casualty, care should be taken when shipping a magazine to see that the guide lugs are pushed all the way forward in the slot in the breech casing before the rear of the magazine is lowered into place.

(d) COCKING INDEX LINE

Occasionally the need arises for some visible indication of whether or not the gun is cocked. In one instance, following a stoppage, the breechblock was retracted to a point where it was supposedly cocked and the safe-fire lever was turned to the "safe" position. The block, however, was actually being held in the retracted position by the cartridge case which had jammed between the block and the breech casing. When one of the personnel, thinking that the mechanism was latched back, partially released the case with his hand, the recoiling mass suddenly moved forward and a serious injury resulted. To prevent a similar occurrence, it is recommended that an index line be painted on one of the breech bars and on the breech casing in such a manner that if the recoiling parts are retracted to the point where the two lines match up, the block will latch back. The recoiling parts should travel about 9/16" beyond the final latched back position in order that the breech pawls may properly engage the lugs on the bottom parallelogram levers. This point can be determined by drawing back the recoiling mass slowly and listening for the click as the pawls pass under the lugs.

(e) PLUGGING OF HOLES IN SHIELD PLATES

Accomplishment of Ordalt No. 1395, by which the shields on 20 mm Mounts, Marks 2 and 4 are lowered to increase the sight field, leaves four unused 17/32 inch diameter holes in each shield plate. It has been suggested that these holes be plugged to prevent the possible passage of small fragments or bullets. It is recommended that, if it is desired to plug the holes, 1/2" bolts (12-Z-24-82), nuts (12-Z-9-5) and lockwashers (12-Z-22-55) be used.

(f) PARALLELOGRAM ASSEMBLY

Damage to the breech pawls, parallelogram levers and trigger crank may result from improper installation of the new type, parallelogram axis bolt, top front (299695-6). When reassembling parallelogram mechanisms having this type of bolt, the head of the bolt must always be installed on the right hand side (looking toward the muzzle). The letter "R" is marked on the head of the axis bolt, and when the bolt is correctly assembled the letter will be visible from the right side. Some of the first of this type of bolt, however, were issued without the letter "R" on the head.

(g) PERMANENT SET OF BARREL SPRINGS

In Ordnance Pamphlet No. 813, 20 mm A.A. Gun and Mount, Mark 4 and Mark 2, it is stated that whenever possible the gun should be kept uncocked in order to relieve the spring tension and prevent the possibility of a permanent set of the barrel springs. This statement also appears in the new Ordnance Pamphlet on the 20 mm A.A. Gun, O.P. 911, which supersedes O.P. 813. However, information now at hand, based on the results of tests conducted by the Naval Gun Factory, indicates that holding the mechanism in the retracted position over long periods of time has a negligible effect upon the life of the barrel springs. It is therefore, considered a satisfactory practice, from the standpoint of barrel spring life, to keep the gun cocked during any period of readiness which the occasion demands.

(h) SAFETY HANDLES FOR EJECTOR ROD ASSEMBLY

The backing out of a projectile from the barrel by means of the ejector rod assembly supplied with the tool roll entails a certain amount of risk. In one instance, a member of a 20 mm A.A. gun crew received serious injuries when, in attempting to back out a projectile, the nose of the projectile was struck with sufficient force to explode the fuze and detonate the burster charge. Even when the ejector tool is applied gently, there is the possibility, in the case of a hot barrel, of the round "cooking off" during the process of removal. In order to lessen the danger to the operating personnel, a new ejector tool is under design, and will consist essentially of a central rod with handles projecting outward and rearward on each side. Using the projecting handles, the operator can keep his hands and arms out of the line of fire of the gun, in the event that the round should detonate. Until such time as the new tool is in production and becomes generally available, it is recommended that all the activities using the 20 mm A.A. gun install auxiliary handles on the present cleaning rod and ejector assembly. A suggested arrangement is to secure (either by welding or by means of an adapter) a U-shape steel bar to the cleaning rod handle assembly (299816-1 or 367516-1) in such a manner that, when the ejector rod is inserted in the barrel, the ends of the bar will project toward the rear and be in the same plane as the barrel bore axis.

(i) SPRING FOR BARREL BORE INSPECTION MIRROR

A new design of barrel bore inspection mirror has recently been approved for production. The new mirror assembly differs from the present design (367517) in that the mirror and its supporting arm can be folded back into the frame to facilitate stowage, and the sides of the frame fit snugly (with spring action) in the magazine slot in the breech casing. Until such time as the new type of mirror assembly becomes available, the bore inspection mirrors now on hand may be altered to provide a retaining spring for securing the mirror assembly to the casing. Figure 3 shows the details of a spring which is intended to be fastened to the under side of the present bore inspection mirror base (367517-2 or 3) by means of rivets. The spring should be located so that the rivets are about $59/64$ " from the rear of the base. Authorization is given for the manufacture and installation of the spring by any service activity that considers it desirable.

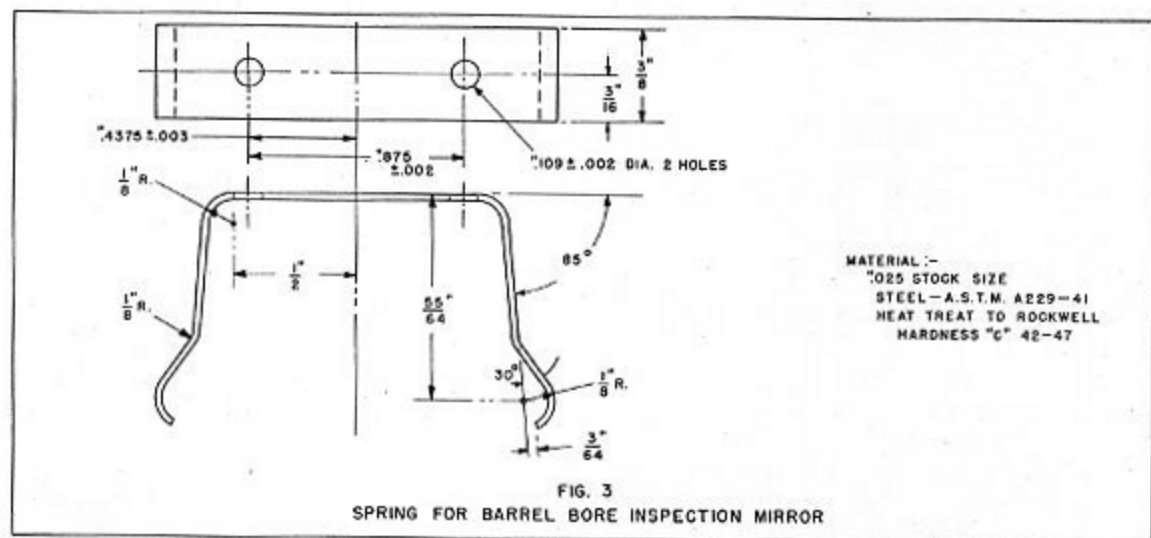

(j) HAMMER PLATE SECURING SPRING

It is considered that some cases of hammer breakage can be attributed to improper seating of the hammer plate (299677-2) rather than to any defect in the hammer itself. If the hammer plate securing spring (299677-1) has been weakened during assembly or disassembly or if it has not been properly seated in its slot in the breech casing, it is possible for the hammer plate to work over into such a position that one of the front toes of the hammer will strike the camming surface intended for the rear toe, resulting in breakage of the hammer. Accordingly, it is recommended that special care be taken during assembly to insure that the securing spring is properly seated in the slot in the breech casing. Regular and frequent inspection of the hammer plate and spring should be made, and if the spring is found to be weak it should be replaced. If the spring is bent out of shape, it should be straightened, or if necessary, replaced.

(k) BREECH FACE PIECE

Peening of the forward end of the striker pin hole in the breech face piece (299651-1) sometimes occurs and interferes with the operation of the striker pin (299653-1) and hammer (299654-1). The face piece should be inspected frequently and, when any evidence of peening is discovered, the striker pin hole should be cleared out to its original diameter.

(1) COTTER PINS FOR TRIGGER AND BARREL LOCKING LEVER

It has been reported that the securing pins (299672-6) used on the trigger (299698-3) and the barrel locking lever (299673-1) are, at first, difficult to remove, and, after several assembly operations, often become loose and drop out. To eliminate this condition it is recommended that the securing pins be replaced with 1/8" x 1" split cotter pins (12-Z-48-38 or 638). In some cases the existing holes may be too small to admit the cotter pins, and should be enlarged by means of a 1/8" drill. Attention is called to the fact that the trigger is hardened to Rockwell "C" 47-53, and special care must be taken in drilling this part. When installing the cotter pin in the trigger, it should always be inserted from the rear in order to prevent the possibility of the split ends jamming between the trigger and the trigger cover.

NAVY DEPARTMENT

BUREAU OF ORDNANCE

WASHINGTON, D. C.

S74(20mm)

(Re5)

April 7, 1943

BUREAU OF ORDNANCE CIRCULAR LETTER NO. GS-43

Subject: 20 mm. A.A. Gun - Muzzle Extension for
Use with Pipe Rail Limit Stops.

Reference: (a) BuOrd Sketch No. 111923.

1. Purpose. This Circular Letter is intended to acquaint the Service (especially Navy Yards) with the muzzle extension shown on reference (a), which may be used where such a device is needed in connection with pipe rail limit stops. In addition, this Circular Letter contains general instructions in regard to the use of train and elevation stops of all types.

2. Pipe rail limit stops, which are under the cognizance of the Bureau of Ships, are installed with 20 mm. A.A. guns in certain locations in certain ships, in order to prevent movement of a gun into areas where the ship's structure would be in the line of fire. In some cases this purpose is served adequately by fixed train stops (independent of the gun elevation angle) and by fixed elevation and depression stops (independent of the angle of train). In other cases, safe limits of train and elevation are not independent one from the other, and it is necessary to provide for a variable limiting angle of elevation or depression which depends upon the angle of train. Pipe rail limit stops are one method of accomplishing this objective.

3. Normally, with a pipe rail stop, the pipe is located so that it will engage the barrel of the gun. Sometimes such a position would interfere with the gunner or another member of the gun crew in operating or serving the gun on the approximate reverse bearing. The best way to avoid this interference is to move the pipe rail further away from the center of rotation of the mount, and to install a muzzle extension on the gun barrel, so that the extension will engage the pipe rail. The design shown by reference (a) is approved for use when a muzzle extension is required for this purpose.

4. Vandyke copies of reference (a) are being sent to all Navy Yards and to all Supervisors of Shipbuilding. These muzzle extensions should be manufactured by the activity making the pipe rail installation, as a charge against

S 74 (20 mm)

ordnance funds, or (in case no ordnance funds are available) the muzzle extensions should be obtained on requisition from the nearest Navy Yard.

5. Pipe rail limit stops for 20 mm. A.A. guns are a temporary expedient, pending the availability of a satisfactory cam type of limit stop. Several designs of cam type stops have been worked up, and a few experimental installations on shipboard have been made. Additional designs are being tested at the Naval Gun Factory. Thus far, no design has been tested that is satisfactory as a standard, for wide spread use. It is expected that one of the designs now under test will be approved in the near future. As soon as a satisfactory cam type limit stop has been tested and is approved, it is planned to issue an Ordalt which will authorize manufacture and installation of the cam type to replace pipe rail stops already installed and to be used instead of pipe rail stops with subsequent installations.

6. The policy of the Bureau of Ordnance in regard to train and elevation limit stops in general, whether of the pipe rail type or the cam type, and as applied to all gun mounts and turrets; regardless of caliber, is outlined as follows:

- (a) The function of these stops is to prevent movement of the gun into a position where its fire would endanger: (1) Any part of the fixed structure of the ship (such as a deck house); or (2) adjacent moveable equipment (such as a crane or a gun mount) with the latter in its position of least interference.
- (b) In considering interferences caused by other moveable equipment, it is obvious that valuable arcs of fire would be lost if the limit stops were set to exclude all possible interferences. Therefore, in general, a limit stop is intended to prevent an interference that can not be avoided otherwise.
- (c) Limit stops are not intended to protect adjacent personnel from blast. An exception to this rule may exist if the adjacent personnel (a director crew, for example) are necessary for the service of the gun. Generally speaking, exposed persons will have to leave their stations if a near-by gun trains into a position where they would be injured by blast.

- (d) The adjustment or machining of limit stops, which will determine the effective limiting angles, is the responsibility of the ship's force. As a general rule, a stop should be set so that with the gun in its limiting position, the axis of the bore of the gun will clear the interfering object by at least one caliber (for guns of 5" bore and larger), or by at least five inches (for guns smaller than 5").

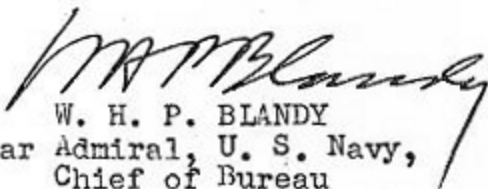
W. H. P. BLANDY
Rear Admiral, U. S. Navy,
Chief of Bureau

STANDARD LIST (No. 8)

- 1 a-n, q-u, w, x, z-ff, ii-oo
2 a, d-j, l-p, t-v, bb
3 a-p, r-ss, uu-yy
B3 200-299, 700-799, 1000, 1199, 1500, 1699, 1800-1999,
10000-10099
4 a-m, o, p, r-ss
5 b(Alusna London only)
7 a-c, f-m, o, u, x, y
8 b, j, k, n(Gunners Mates only), q-s, u, v, x, z
10 f-j, m, n
11a (USMC Hdqtrs only), BuShips, VOpNav, BuOrd
12 a
14 a, i-k, m, n, q, s

NAVY DEPARTMENT

BUREAU OF ORDNANCE

S74(20mm)
(Re 5d)

NAVORD OCL G21-44
17 April 1944

WASHINGTON, D. C.

RESTRICTED

BUREAU OF ORDNANCE CIRCULAR LETTER G21-44

Subject: 20mm Machine Gun Mechanisms Mark 2 and Mark 4,
20mm Magazines Mark 2 and Mark 4 - Permanent
Set of Barrel Springs and Magazine Springs.

Reference: (a) Ordnance Pamphlet No. 911.

1. The question has arisen in the service as to the length of time that a 20mm anti-aircraft gun can be kept cocked and the length of time that a 20mm magazine can be held under full tension, without damage to the barrel springs or to the magazine spring.

2. As previously stated in Addendum 1 (dated 12 July 1943) of reference (a), the results of tests conducted on the barrel springs indicate that the gun may be held in the cocked position over long periods of time with negligible permanent set.

3. Recent tests on the magazine spring indicate that the magazine spring may be stored in the fully tensioned condition over long periods without appreciable loss in tension.

4. It is considered to be a satisfactory practice, from the standpoint of the life and performance of the barrel springs and the magazine springs, to keep the gun cocked and the magazine fully tensioned during any period of readiness which the occasion demands.

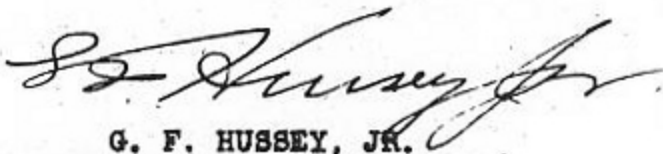

G. F. HUSSEY, JR.
Rear Admiral, U. S. Navy
Chief of Bureau

RESTRICTED

NAVORD OCL G21-44
17 April 1944

Requests for additional copies of OCL G21-44 should be directed to the nearest BuOrd Publications Distribution Center: Navy Yard, Washington, D.C.; Mare Island, California; Adak, Alaska; Pearl Harbor, Hawaii; Espiritu Santo, New Hebrides; Exeter, England. Distribution Center mailing addresses should be obtained from list 10 nn on the Standard Navy Distribution List.

DISTRIBUTION

Standard Navy Distribution List No. 22
2 copies each unless otherwise noted.

1. (1 copy), k, l; 1. a-e, g-i, m, n, q-u, w, x, z-ff, ii-oo, qq-uu, ww-zz; 2. (except a, i, j, l, p, s); 3. (except s); B3. CONSTRUCTION BATTALIONS; 4. (except g, o, s, ss, zz);
5. b; 6. a-p, v; 7. e-i, o, u, x, aa, cc-ee; 7. (5 copies), b, d, j, l, p, s; 7. (10 copies), a;
8. b, h, j, k, n (SPECIAL LIST K, L, V, AA); q, u, v, x, z, ll; 8. (200 copies), r; 10. i, j, t;
10. (200 copies), s; 10. (25 copies), nn; 11. a (ComdtMarCorps); 12. a, b (Revision 1), d;
14. a-d, q.

NAVY DEPARTMENT
BUREAU OF ORDNANCE

RESTRICTED

Washington, D. C., 21 September 1943.

BUREAU OF ORDNANCE CIRCULAR LETTER NO. G33-43

Subject: Ordnance Pamphlet No. 911, 20-mm. Machine Gun Mechanism Mks. 2 and 4; 20-mm. Gun Barrel Mks. 2, 3, 4, 4-1. Addendum 2.

Enclosure: (A) Addendum 2 to Subject Ordnance Pamphlet (page 86a).

1. Insert enclosure (A) in subject Ordnance Pamphlet and write on cover, "Addendum 2 entered."

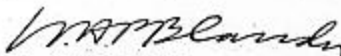
W. H. P. BLANDY,
Rear Admiral, U. S. Navy,
Chief of the Bureau of Ordnance.

(Enclosure A)

ADDENDUM 2 to OP 911.

OP 911 is changed as follows:

PAGE 86: Add this sheet as page 86a.

A small quantity of pentolite loaded 20-mm. ammunition was manufactured in this country for Lend Lease and in a few instances was issued to US vessels. HEI-T, tetryl loaded, 20-mm. has never been placed in production. However, the above rounds are included in the color chart to permit identification in event any of these types are issued to US vessels from British sources.

DISTRIBUTION:

Standard Navy Distribution List No. 15, 2 copies each unless otherwise noted.

1. a-h, j-n, q-u, w, x, z-ff, ii-ll, nn, oo, qq-zz; 2. a, d-j, l-p, r, s, v, aa, dd; 3. c, d, e, g, i, j, k, l, m*, n, o, p*, r, s, t, u, v, w*, x-z, aa*, bb-ee, ff*, gg, hh, ii*, jj, kk, ll, mm, nn*, oo*, pp*, qq-vv, ww*, xx-aaa, bbb*, ccc*, ddd-fff; 3. (5 copies), a, f; B3. CONSTRUCTION BATTALIONS; B3. (5 copies, LIONS, CUBS, ACORNS); 4, b, c, d, e, g, i-l, m*, o, p, r-yy; 4. (5 copies), a, f; 5. b (Alusna, London only), e; 6. a-p; 7. f-i, x, y; 7. (5 copies), b, c, j, l, p; 7. (10 copies), a; 8. h (NOL and No. Beach only), i, j, n (SPECIAL LIST K, L, R, S, V, X, Z, AA), r, u, v, x, z; 10. s, t; 11. a (BuDocks, Vice CNO, SecNav, ComdtMarCorps); 12.; 14. a; OCO, War Dept; Auxiliary Proofing Range.

*Applicable Ships.

Requests for this publication should be addressed to the nearest BuOrd Publications Distribution Center: Comdt and Supt, NavGun, NYd, Wash. 25, D. C.; Comdt, NYd, Mare Island, Calif.; OinC, OrdPubSubcen, NSD, Pearl; ComSerFor, Seventh Fleet, OrdPubSubcen, % FPO, San Fran.