

**CONFIDENTIAL**

**OP 2074**

---

# **COMPUTER MARK 48 MOD 1**

**DESCRIPTION, OPERATION,  
INSTALLATION, AND MAINTENANCE**



**CONFIDENTIAL**

---

**29 SEPTEMBER 1956**



DEPARTMENT OF THE NAVY

BUREAU OF ORDNANCE  
WASHINGTON 25, D. C.

19 September 1956

CONFIDENTIAL

ORDNANCE PAMPHLET 2074

COMPUTER MARK 48 MOD 1 - DESCRIPTION, OPERATION, AND MAINTENANCE

1. Ordnance Pamphlet 2074 contains the description and instructions for operation and maintenance of Computer Mark 48 Mod 1.
2. This publication is intended for use by all personnel concerned with operation and maintenance of the subject computer.
3. This publication does not supersede any existing publication.
4. This publication is CONFIDENTIAL and shall be safeguarded in accordance with the security provisions of U. S. Navy Regulations, United States Navy Security Manual for Classified Matter (OPNAVINST 5510.1A), and Armed Forces Industrial Security Regulation (OPNAVINST 5540.8). As stated in Article 0906.2 of OPNAVINST 5510.1A, dated 2 October 1954, it is forbidden to make extracts from or to copy this classified document without authorization.

F. S. WITHINGTON

A handwritten signature in dark ink, appearing to read "Paul D. Stroop", is written over the typed name.

PAUL D. STROOP  
Rear Admiral, U. S. Navy  
Deputy Chief, Bureau of Ordnance

CONFIDENTIAL

CONTENTS

Chapter	Page
1. INTRODUCTION . . . . .	1
Purpose . . . . .	1
Function . . . . .	1
Associated Fire Control Systems . . . . .	3
References . . . . .	3
Scope . . . . .	3
2. PHYSICAL DESCRIPTION . . . . .	7
Mechanical Section and Plotter . . . . .	7
Electronic Section . . . . .	7
Inputs and Outputs . . . . .	7
Operating Limits . . . . .	14
Transmitter and Receiver Synchros . . . . .	14
Motor-Generator Set . . . . .	17
3. OPERATION . . . . .	19
Operating Controls . . . . .	19
Test Controls . . . . .	19
Plotter and Protractor . . . . .	25
Shore-Bombardment Auxiliary Switchboard . . . . .	26
Motor-Generator Controls . . . . .	28
Operating Procedure . . . . .	28
Initial Operating Setup . . . . .	29
SHORE-BOMBARDMENT Mode . . . . .	29
Changing from SHORE-BOMBARDMENT Mode to LOCAL CONTROL Mode . . . . .	33
LOCAL CONTROL Mode . . . . .	33
SHIP-TO-SHIP Mode . . . . .	33
DEAD RECKONING Mode . . . . .	35
Special Modes of Operation . . . . .	36
Manual Plotting . . . . .	36
Area Fire . . . . .	36
Firing on Roads and Runways . . . . .	37
Parallax Correction . . . . .	37
4. THEORY AND FUNCTIONAL DESCRIPTION . . . . .	39
Section 4. 1—Theory . . . . .	39
Geometric Quantities . . . . .	39
Instrument Solution . . . . .	40
Section 4. 2—Function . . . . .	42
Functional Description of Horizontal Section . . . . .	42
Transmitted Inputs . . . . .	42

## CONTENTS (Cont'd)

Chapter	Page
Computation of Elevation and Horizontal Range of Reference . . .	44
Approximation of Bearing Correction . . . . .	44
Coordinate Conversion . . . . .	49
Computation of Target Horizontal Coordinates and Conversion to Polar Coordinates . . . . .	49
Computation of Target Slant Range and Elevation Angle . . . . .	49
Parallax Computation . . . . .	53
Generation of Range and Ship's Motion . . . . .	55
Selection of Coordinates and Plot . . . . .	57
Functional Description of Deck-Tilt Section . . . . .	60
Inputs . . . . .	60
Computation of Target-Bearing Deck-Tilt Correction . . . . .	64
Computation of Combined Deck-Tilt Corrections . . . . .	64
Summation of Reference-Bearing Corrections . . . . .	67
Summation of Target-Relative-Bearing Terms . . . . .	67
DIRECTOR SELECTOR Switch . . . . .	69
Reference-Point Deck-Tilt Computation . . . . .	72
 5. MAINTENANCE	 75
Section 5.1—Cleaning, Lubrication, and Inspection . . . . .	75
Schedule . . . . .	75
Cleaning . . . . .	75
Lubrication . . . . .	76
Inspection . . . . .	76
Section 5.2—Routine Tests . . . . .	77
List of Test-Form Drawing Numbers . . . . .	77
Frequency of Tests . . . . .	77
Test Input Settings . . . . .	78
Calculation of Errors . . . . .	78
A Tests . . . . .	79
Generation Tests . . . . .	82
Test for Generation of $\Delta X_o$ and $\Delta Y_o$ . . . . .	82
Test for Generation of $\Delta cR$ . . . . .	84
Transmission Tests . . . . .	84
Receiver Accuracy Test . . . . .	86
Receiver Synchronization Test . . . . .	86
Accuracy Test of OB'r', OR, Et, and Ph Transmitters . . . . .	86
Accuracy Test of $\Delta cR$ Transmitter . . . . .	86
Test of L', Zd, and L' + Zd/30 Transmitters . . . . .	95
Test of Co + jB'r' - jB Transmitter . . . . .	96
Time Motor Regulator Test . . . . .	96
Index-Light Travel Test . . . . .	97
Test for Xp Travel . . . . .	98
Test for Yp Travel . . . . .	98

CONTENTS (Cont'd)

Chapter	Page
Section 5.3—Trouble Shooting . . . . .	100
Common Mechanical and Electrical Faults . . . . .	100
Component Identification . . . . .	101
Test Unit . . . . .	103
Reading and Interpretation of Test-Unit Dials . . . . .	107
Test-Unit Operating Procedure . . . . .	107
Special Applications . . . . .	108
Neon Monitoring System . . . . .	110
Fuses . . . . .	113
A-Test Analysis . . . . .	113
Generation Test Analysis . . . . .	142
Transmission Test Analysis . . . . .	145
Index-Light Travel Test Analysis . . . . .	148
Schematics of Computing Mechanisms . . . . .	149
Section 5.4—Trouble Shooting Electronic Units . . . . .	152
Procedure . . . . .	152
Preliminary Check . . . . .	166
Trouble Shooting Tests . . . . .	166
Electronic Element Reference Table . . . . .	167
Location of Electronic Elements . . . . .	167
Access to Electronic Elements . . . . .	167
Special Potentiometer Settings for Tests . . . . .	167
Test Equipment . . . . .	239
Transformers and Chokes . . . . .	239
Servo Control Potentiometer Settings . . . . .	245
Resolver Trimming Procedure . . . . .	245
Section 5.5—Adjustment, Assembly, and Disassembly . . . . .	254
Adjustment Procedure . . . . .	254
Assembly and Disassembly . . . . .	255
6. INSTALLATION . . . . .	287
APPENDIX A . . . . .	293

## ILLUSTRATIONS

Figure		Page
1	Fire at an Obscured Target . . . . .	xii
2	Direct and Indirect Fire Control . . . . .	2
3	Two-Axis (MB) Indirect Fire Control Systems . . . . .	4
4	Three-Axis (AA) Indirect Fire Control Systems . . . . .	5
5	Computer Mk 48 Mod 1 . . . . .	6
6	Test Unit . . . . .	8
7	Controls on Top of Computer Mk 48 Mod 1 . . . . .	9
8	Controls on Front of Computer Mk 48 Mod 1 . . . . .	10
9	Dials on Right Side of Computer Mk 48 Mod 1 . . . . .	11
10	Mk 48 Mod 1, Mechanical Section, Computer, Rear View . . . . .	12
11	Mk 48 Mod 1, Electronic Section, Computer, Rear View . . . . .	13
12	R, B'r', and So Handcranks Installed . . . . .	18
13	Parallel Motion Protractor . . . . .	27
14	Transverse Mercator Projection Chart Mounted on Plotter . . . . .	30
15	Horizontal Quantities Obtained from Plotter and Map . . . . .	38
16	Angles Involved in Indirect Fire Control . . . . .	41
17	Schematic Symbols . . . . .	43
18	Co, R, or B'r' Receiver . . . . .	45
19	So Receiver and Follow-up . . . . .	46
20	Computation of Es and Rh . . . . .	47
21	Computation of jB . . . . .	48
22	Conversion of Reference Point Horizontal Coordinates . . . . .	50
23	Conversion of Target Coordinates . . . . .	51
24	Computation of OR and Et . . . . .	52
25	Computation of Ph and Ph Follow-up . . . . .	54
26	Computation of $\Delta cR$ , $\Delta Xo$ , and $\Delta Yo$ . . . . .	56
27	Target, Reference, and Spot Coordinate Inputs to Computer Mk 48 Mod 1 . . . . .	58
28	Scale Factor and Coordinate Inputs to Plotter . . . . .	59
29	Flow Diagram of Horizontal Section . . . . .	61
30	OL' and OZh Receivers . . . . .	62
31	Resolution of Target LOS Deck-Tilt Angles . . . . .	63
32	Computation of jOB'r' . . . . .	65
33	Computation of jOB'r' - jB'r' . . . . .	66
34	Summation of Reference Bearing Corrections . . . . .	68
35	Summation of Target Relative Bearing Terms . . . . .	70
36	Computation of Reference LOS Deck-Tilt Angles . . . . .	71
37	Flow Diagram of Deck-Tilt Section . . . . .	73
38	Test-Unit Operating Controls . . . . .	102
39	Test Unit, Schematic Diagram . . . . .	104
40	Test Unit Removed From Case . . . . .	105
41	Test-Unit Connections to Computer Mk 48 Mod 1 . . . . .	106
42	In-Phase and Quadrature Components of 20-Degree Voltage Vector . . . . .	109
43	Computer Mk 48 Mod 1, Front Electronic Section . . . . .	111
44	Trouble Shooting, Overall Block Schematic A-Test . . . . .	112

## ILLUSTRATIONS (Cont'd)

Figure		Page
45	Test Analysis, Block Schematic Generation . . . . .	146
46	Typical Servo Loop . . . . .	150
47	$\Delta cR$ , $\Delta Yo$ , and $\Delta Xo$ Group . . . . .	153
48	Es and Rh Loop . . . . .	154
49	jB Loop and B Resolver . . . . .	155
50	Coordinate Inputs and Mode-and-Plot Switch Group . . . . .	156
51	Plotter Group . . . . .	157
52	ORh and OB Computing Loop . . . . .	158
53	Et and OR Loop . . . . .	159
54	OL' and OZh Resolver Group . . . . .	160
55	L' and Zh Computing Loops . . . . .	161
56	jOB'r' - jB'r' Loop . . . . .	162
57	jOB'r' Loop . . . . .	163
58	OB'r' Differentials . . . . .	164
59	Parallax Group . . . . .	165
60	Key Diagram for Figures 61 through 66 . . . . .	176
61	Electronic Section, Front Drawer - Front View (Section A, Figure 60).	177
62	Electronic Section, Front Drawer - Rear View (Section B, Figure 60).	178
63	Electronic Section, Center Wall - Front View (Section C, Figure 60).	179
64	Electronic Section, Center Wall - Rear View (Section D, Figure 60).	180
65	Electronic Section, Rear Drawer - Rear View (Section E, Figure 60).	181
66	Electronic Section, Rear Drawer - Front View (Section F, Figure 60)	182
67	Front Electronic Section, Cover No. 4 Removed . . . . .	183
68	Front Drawer Pulled Out . . . . .	184
69	Front Drawer Out, Baskets Swung Down . . . . .	185
70	Front Drawer Out, Baskets Opened . . . . .	186
71	Typical Electronic Element of Computer Mk 48 Mod 1 . . . . .	187
72	Servo Amplifier, 60-cycles, Schematic Diagram (Unit 3201) . . . . .	188
73	Tuning Fork Amplifier, 400-cycles Schematic Diagram (Unit 3402) . . . . .	192
74	Single-Channel Amplifier, Schematic Diagram (Unit 3001) . . . . .	196
75	Computing Amplifier, Dual-Channel, Schematic Diagram (Unit 3012) . . . . .	201
76	Dual-Channel Amplifier, Schematic Diagram (Unit 3002) . . . . .	204
77	Computing Amplifier, Variable-Feedback, Schematic Diagram (Unit 3011) . . . . .	207
78	Servo Control, Double-Speed, Velocity-Lag, Schematic Diagram (Unit 3304) . . . . .	211
79	Servo Control, Velocity-Lag, 400-cycles, Schematic Diagram (Unit 3301) . . . . .	215
80	Servo Control, High-Fidelity, Schematic Diagram (Unit 3302) . . . . .	219
81	Servo Control, Double-Speed, Schematic Diagram (Unit 3305) . . . . .	225
82	+250-v DC Power Supply, Schematic Diagram (Unit 3803) . . . . .	229
83	-105-v DC Power Supply, Schematic Diagram (Unit 3804) . . . . .	232
84	Time Delay Control, Schematic Diagram (Unit 1903) . . . . .	235
85	Tuning Fork Oscillator, 400-cycles Schematic Diagram (Unit 3401) . . . . .	237
86	Schematic of Null Measuring System for Resolver Trimming . . . . .	248
87	Method of Connecting Rs and Cs . . . . .	249
88	Method of Connecting Rf and Cf. . . . .	250

## ILLUSTRATIONS (Cont'd)

Figure		Page
89	Front Mechanical Section Under Cover No. 5 . . . . .	257
90	Right Mechanical Section Under Cover No. 6 . . . . .	260
91	Mechanical Section Left Wall as Viewed from Right Side . . . . .	263
92	Front and Back Sides of Hinged Plate . . . . .	267
93	Plotter Mechanical Section Under Cover No. 1 . . . . .	271
94	Rear Mechanical Section Under Cover No. 7 . . . . .	275
95	Top Mechanical Section Below Plotter and Cover No. 3 . . . . .	279
96	Lower Mechanical Section (Floor Plan) . . . . .	283
97	Computer Mk 48 Mod 1, Mounting Diagram . . . . .	286
98	External Synchro Cable Connections . . . . .	288
99	External Power Cable Connections . . . . .	289
100	Left Side with Electronic Drawers Extended . . . . .	290

## TABLES

Table		Page
1	Limit Stops . . . . .	15
2	Transmitter and Receiver Synchros . . . . .	16
3	Controls on Top Panel of Computer Mk 48 Mod 1 . . . . .	20
4	Controls on Front Panel of Computer Mk 48 Mod 1 . . . . .	23
5	Controls on Right Side of Computer Mk 48 Mod 1 . . . . .	24
6	Controls on Rear of Computer Mk 48 Mod 1 . . . . .	25
7	Controls on Motor-Generator Set . . . . .	29
8	Initial Operating Setup . . . . .	31
9	SHORE-BOMBARDMENT Mode of Operation . . . . .	34
10	LOCAL CONTROL Mode of Operation . . . . .	34
11	Mode-and-Plot Switch Functions . . . . .	60
12	A Tests Independent Variables . . . . .	80
13	A-Test Transmitted Quantities . . . . .	81
14	Test for Generation of $\Delta X_o$ and $\Delta Y_o$ . . . . .	83
15	Test for Generation of $\Delta cR$ . . . . .	85
16	Receiver Accuracy Test . . . . .	87
17	Receiver Synchronization Test . . . . .	94
18	Accuracy Test—Direct Reading Transmitters . . . . .	94
19	Accuracy Test— $\Delta cR$ Transmitter . . . . .	95
20	Accuracy Test—Director Level and Cross Level . . . . .	96
21	Accuracy Test—Train Control . . . . .	97
22	Time Motor Regulator Test . . . . .	97
23	Test for Index-Light Travel . . . . .	99
24	Fuses . . . . .	114
25	A-Test Troubleshooting . . . . .	115
26	Mechanical Intermediate Quantities for A Tests . . . . .	116
27	A-Test Electrical Intermediate Quantities . . . . .	117
28	Test of Operating Limits . . . . .	123
29	Test for Deck-Tilt Correction Computation (MB) . . . . .	125
30	Test for Deck-Tilt Correction Computation (AA) . . . . .	129
31	Test for Elevation Point of Aim (Es) Computation . . . . .	137
32	Test for Target Elevation (Et) and Target Range (OR) . . . . .	138
33	Test for $X_p$ and $Y_p$ Computation . . . . .	143
34	Test for Horizontal Parallax (Ph) Computation . . . . .	145
35	$\Delta X_o$ and $\Delta Y_o$ Error Analysis . . . . .	147
36	$\Delta cR$ Error Analysis . . . . .	147
37	Servo Loop Elements . . . . .	151
38	List of Functional Schematics . . . . .	152
39	Electronic Elements . . . . .	168
40	Unit 3201 - Resistance and Voltage Tests . . . . .	189
41	Unit 3201 - Parts List . . . . .	191
42	Unit 3402 - Resistance and Voltage Tests . . . . .	193
43	Unit 3402 - Parts List . . . . .	195
44	Unit 3001 - Resistance and Voltage Tests . . . . .	197

## TABLES (Cont'd)

Table	Page	
45	Unit 3001 - Parts List . . . . .	200
46	Unit 3012 - Resistance and Voltage Tests . . . . .	202
47	Unit 3012 - Parts List . . . . .	203
48	Unit 3002 - Resistance and Voltage Tests . . . . .	205
49	Unit 3002 - Parts List . . . . .	206
50	Unit 3011 - Resistance and Voltage Tests . . . . .	208
51	Unit 3011 - Parts List . . . . .	210
52	Unit 3304 - Resistance and Voltage Tests . . . . .	212
53	Unit 3304 - Parts List . . . . .	214
54	Unit 3301 - Resistance and Voltage Tests . . . . .	216
55	Unit 3301 - Parts List . . . . .	218
56	Unit 3302 - Resistance and Voltage Tests . . . . .	220
57	Unit 3302 - Parts List . . . . .	224
58	Unit 3305 - Resistance and Voltage Tests . . . . .	226
59	Unit 3305 - Parts List . . . . .	228
60	Unit 3803 - Resistance Voltage Tests . . . . .	230
61	Unit 3803 - Parts List . . . . .	231
62	Unit 3804 - Resistance and Voltage Tests . . . . .	233
63	Unit 3804 - Parts List . . . . .	234
64	Unit 1903 - Resistance Tests . . . . .	236
65	Unit 3401 - Resistance and Voltage Tests . . . . .	238
66	Transformers and Chokes Reference Index . . . . .	240
67	Transformers and Chokes Resistance Measurements . . . . .	241
68	Transformers and Chokes Voltage Measurements . . . . .	243
69	Servo Control Potentiometer Settings . . . . .	246
70	Adjustment Procedure . . . . .	255
71	Operating Voltages . . . . .	287
72	System Transmission Components . . . . .	291

One Deluxe Blank Page.

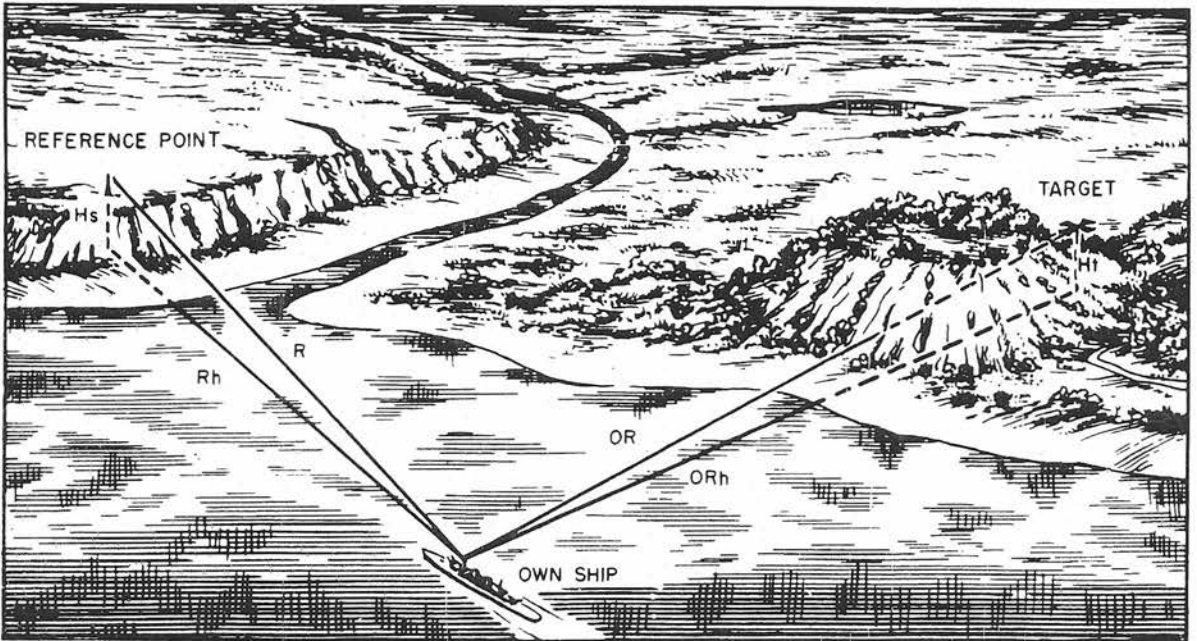

Figure 1. Fire at an Obscured Target

## Chapter 1

## INTRODUCTION

## PURPOSE

Computer Mk 48 Mod 1 operates in conjunction with the gun order computer, stable element, and director to provide an accurate solution to the problem of shore bombardment by indirect fire. It is designed to operate with the main and secondary batteries of cruisers and battleships, and may be used with anti-aircraft or surface fire directors and computers or range keepers.

## FUNCTION

Computer Mk 48 Mod 1 primarily is designed to solve a fire control problem by using a visible reference point to direct fire at an obscured target whose map location with respect to the reference point is known, figure 1. This computer translates data that describe reference point position with respect to the ship into data that describe actual target position with respect to the ship. Figure 2 shows the data flow for direct and for indirect fire control. The data that describe target position with respect to the ship then are transmitted to the gun order computer for computation of firing data.

In indirect fire, Computer Mk 48 Mod 1 computes the quantities involved in target location by combining three sets of data:

Location of the reference point with respect to the ship. The reference point, at which the director is continuously aimed, is located by its relative bearing, range, and height.

Location of the target with respect to the reference point. This is established by X-Y map coordinates, reference point height, and target height.

Level and cross level referenced to the target line-of-sight.

By combining these three sets of data, Computer Mk 48 Mod 1 furnishes to the gun order computer the following quantities:

Offset relative target bearing  
(director train to target)

Target slant range

Target elevation

In addition to transmitting target data to the gun order computer, Computer Mk 48 Mod 1 transmits data to the gun director to keep it aimed at the reference point. To achieve this, the following quantities are transmitted:

Changes in slant range to reference point

Unit parallax computation (Gun Director Mk 37)

Reference point bearing corrections

Level (with respect to reference point line of sight) to main battery directors

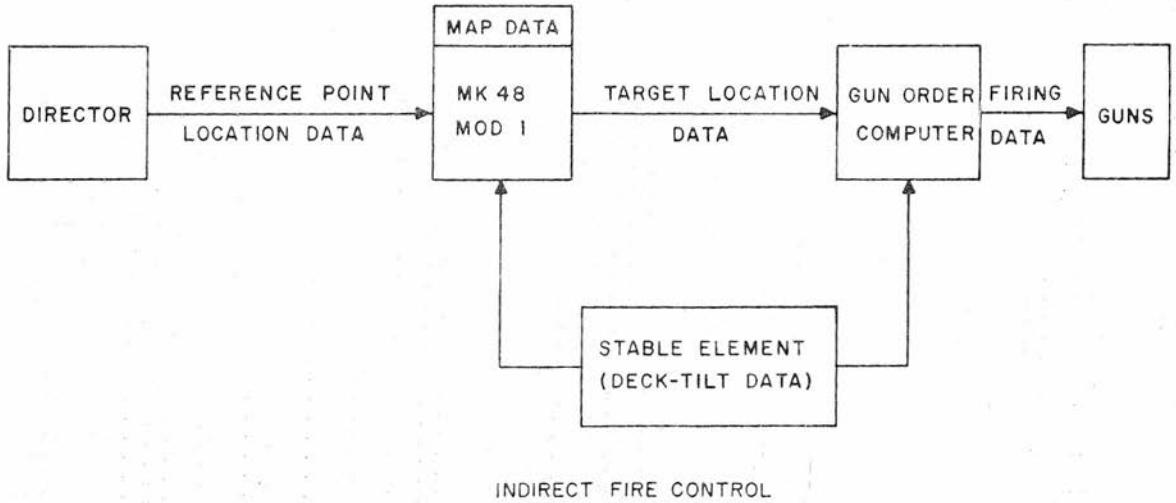
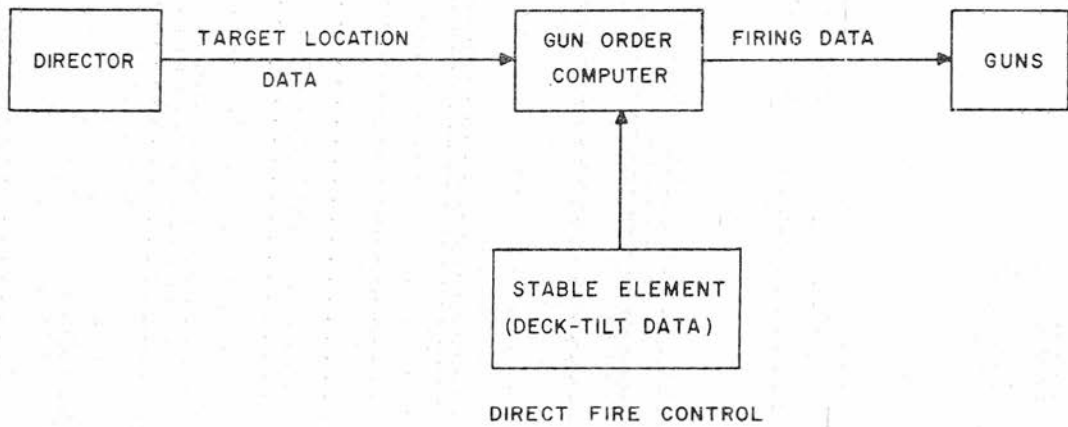

Figure 2. Direct and Indirect Fire Control

Cross level and level plus a function of cross level (with respect to reference point director line of sight) to Gun Director Mk 37

These quantities are described in chapter 4.

Computer Mk 48 Mod 1 also can perform the following functions:

Local control when director information is not available

Dead reckoning navigation

Determine set and drift by plotting successive target positions

Since an antiaircraft, AA, fire control system, generally used with the secondary batteries, is a three-axis system, and the main battery, MB, system generally used for surface fire is a two-axis system, differences exist between the systems in the method of measuring some angles involved in the fire control problem. This necessitates two solutions for some of the quantities computed by Computer Mk 48 Mod 1, one solution for MB and one for AA. For simplicity, fire control symbols for a two-axis system are used throughout this publication and, where necessary for clarity, equivalent three-axis symbols are included in parentheses. The method by which Computer Mk 48 Mod 1 computes for the two types of systems is described in chapter 4.

#### ASSOCIATED FIRE CONTROL SYSTEMS

Computer Mk 48 Mod 1 is designed to function with Gun Directors Mk 34, Mk 37, Mk 38, and Mk 54; Stable Vertical Mk 41 and Stable Element Mk 6; Range Keeper Mk 8 with Target Elevation Indicator Mk 66; and Computer Mk 1A (figures 3 and 4).

#### REFERENCES

Gun Director Mk 34:	OP 1057
Gun Director Mk 37:	OP 1060
Gun Director Mk 38:	OP 810
Gun Director Mk 54:	OP 1352
Stable Vertical Mk 41:	OP 1170
Stable Element Mk 6:	OP 1063
Range Keeper Mk 8:	OP 1068
Computer Mk 1A:	OP 1064

#### SCOPE

This publication contains operating, maintenance, and installation instructions for Computer Mk 48 Mod 1. Physical and functional descriptions of the instrument also are given. Maintenance procedures contained in chapter 5 include instructions for using the special portable test unit supplied with the instrument.

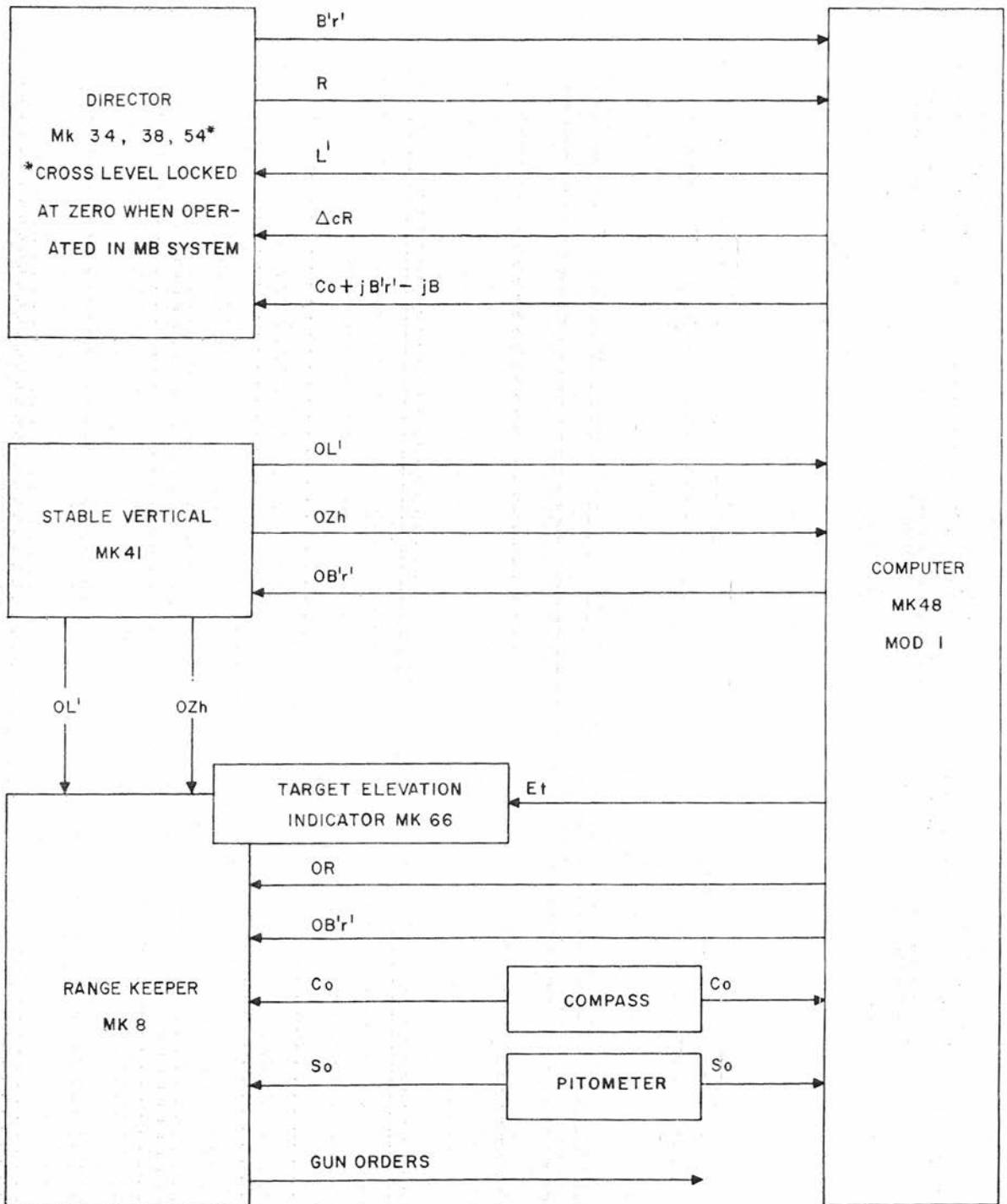

Figure 3. Two-Axis (MB) Indirect Fire Control Systems

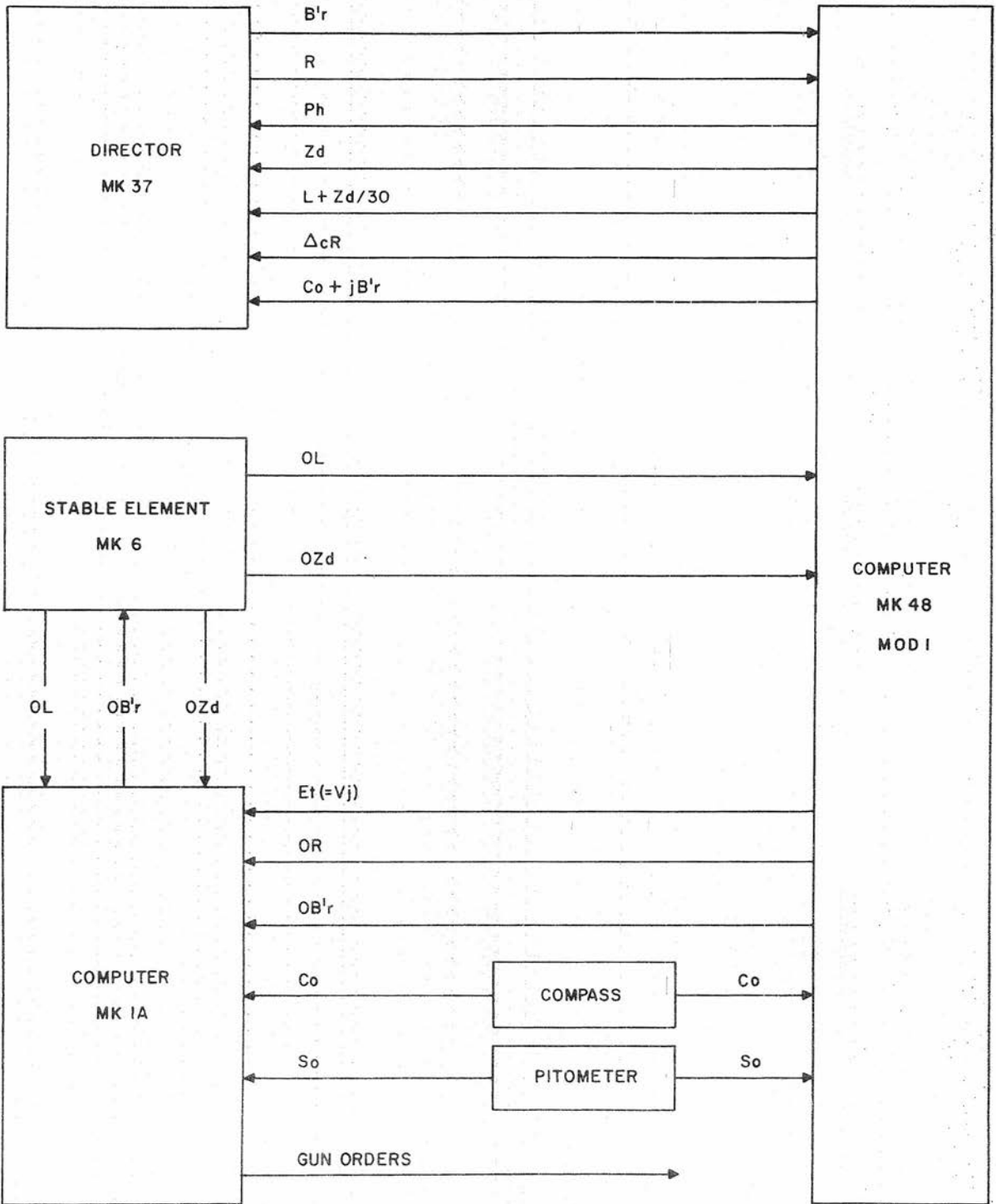

Figure 4. Three-Axis (AA) Indirect Fire Control Systems

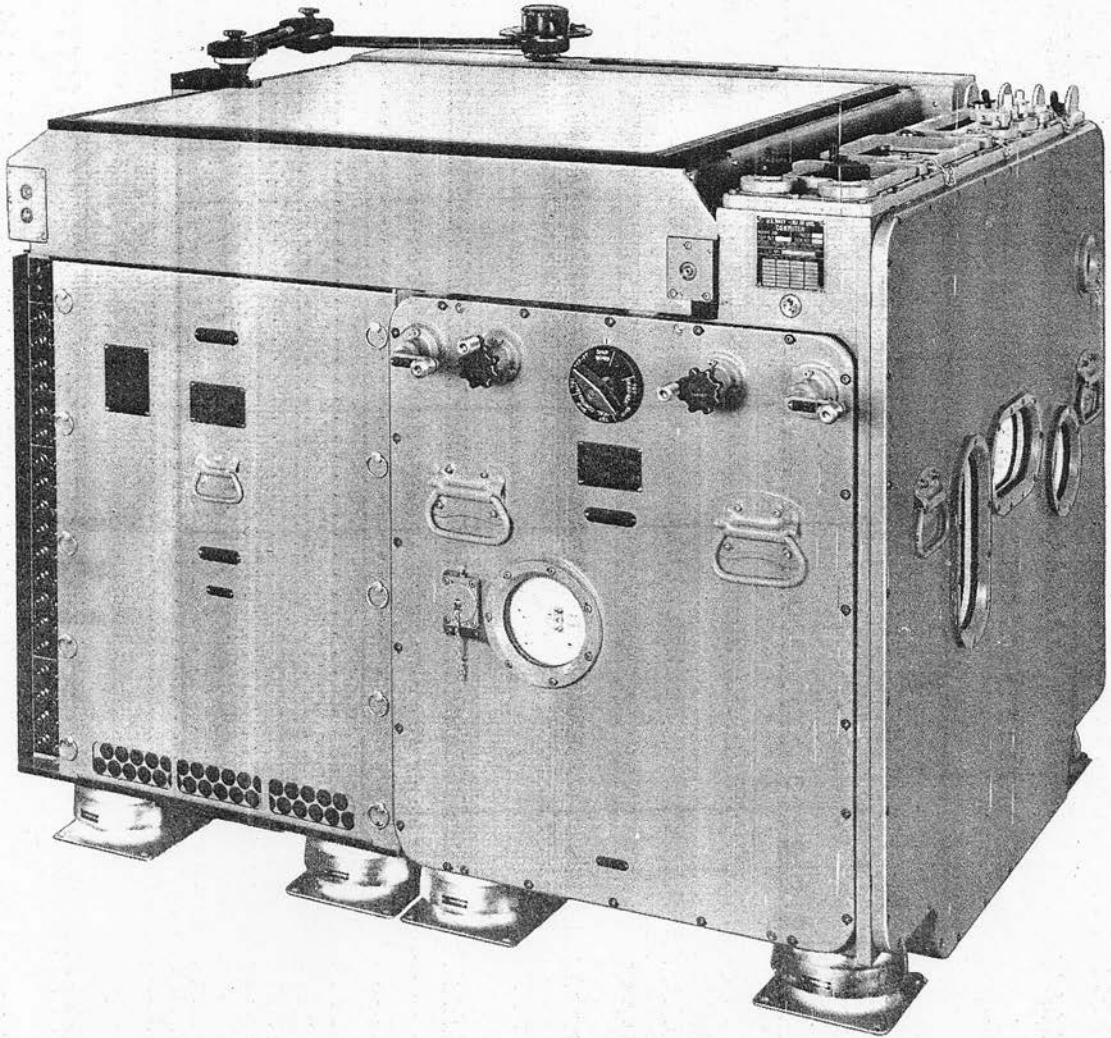

Figure 5. Computer Mk 48 Mod 1

## Chapter 2

## PHYSICAL DESCRIPTION

Computer Mk 48 Mod 1 contains electro-mechanical and electronic devices arranged as a mechanical section, an electronic section, and a plotter assembled together as shown in figure 5. A separate motor-generator set with controls supplies 350-volts DC to the computer. This set is not part of the computer and is maintained by a different activity. A portable test unit, figure 6, for measuring the value of computed voltages is furnished with the equipment. The computer weighs 2136 pounds and is shock-mounted on the deck. The portable test unit weighs about 75 pounds.

## MECHANICAL SECTION AND PLOTTER

The plotter covers the top of the mechanical and electronic sections, except for a narrow strip on the mechanical section that carries operating controls, figure 7. A parallel motion protractor is attached to the plotter. The protractor is not used for indirect fire control, but is furnished for auxiliary functions described in chapter 3.

Additional operating controls are on the front of the mechanical section, figure 8. On the right side of this section are transmitter check dials and the radar beacon delay spot, Rj, dial, figure 9. The SCALE FACTOR counter and handcrank are on the rear panel of the mechanical section, figure 10. Within the mechanical section are all the receivers, computing and generating mechanisms, and transmitters of Computer Mk 48 Mod 1.

## ELECTRONIC SECTION

The electronic section houses the network boxes, amplifiers, servo controls, and switching circuitry. On the front panel of the electronic section are the lights and switches of the neon monitoring system. Test-unit connectors, voltmeters, and fuses are on panels at the rear, figure 11.

## INPUTS AND OUTPUTS

The manual inputs are set into the plotter with a knob or crank either by positioning a dial or counter or by positioning the plotter index light. The automatic inputs are received by synchro transmission. However, to test the computer, some normally automatic inputs (ship speed, ship course, range, and director train) may be set manually. Outputs are by synchro transmission. The inputs and outputs of Computer Mk 48 Mod 1 are:

## Manual Inputs

Height of reference point,  $H_s$

Height of target,  $H_t$

East-west position of own ship,  $X_o$

North-south position of own ship,  $Y_o$

East-west position of reference point,  
 $X_a$

North-south position of reference  
point,  $Y_a$

East-west position of target,  $X_t$

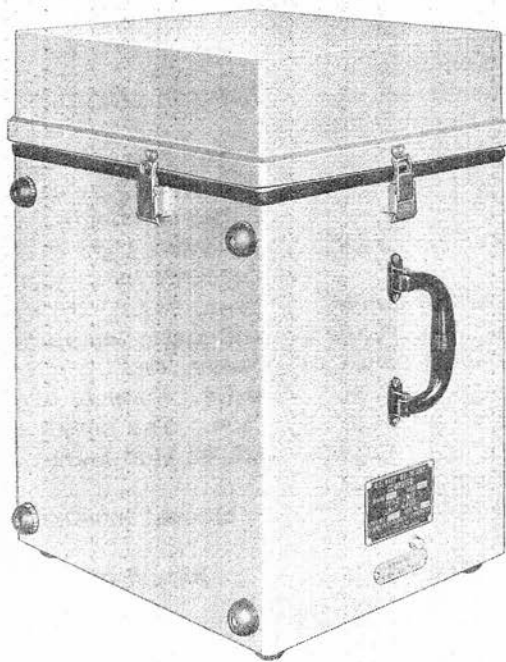

Figure 6. Test Unit

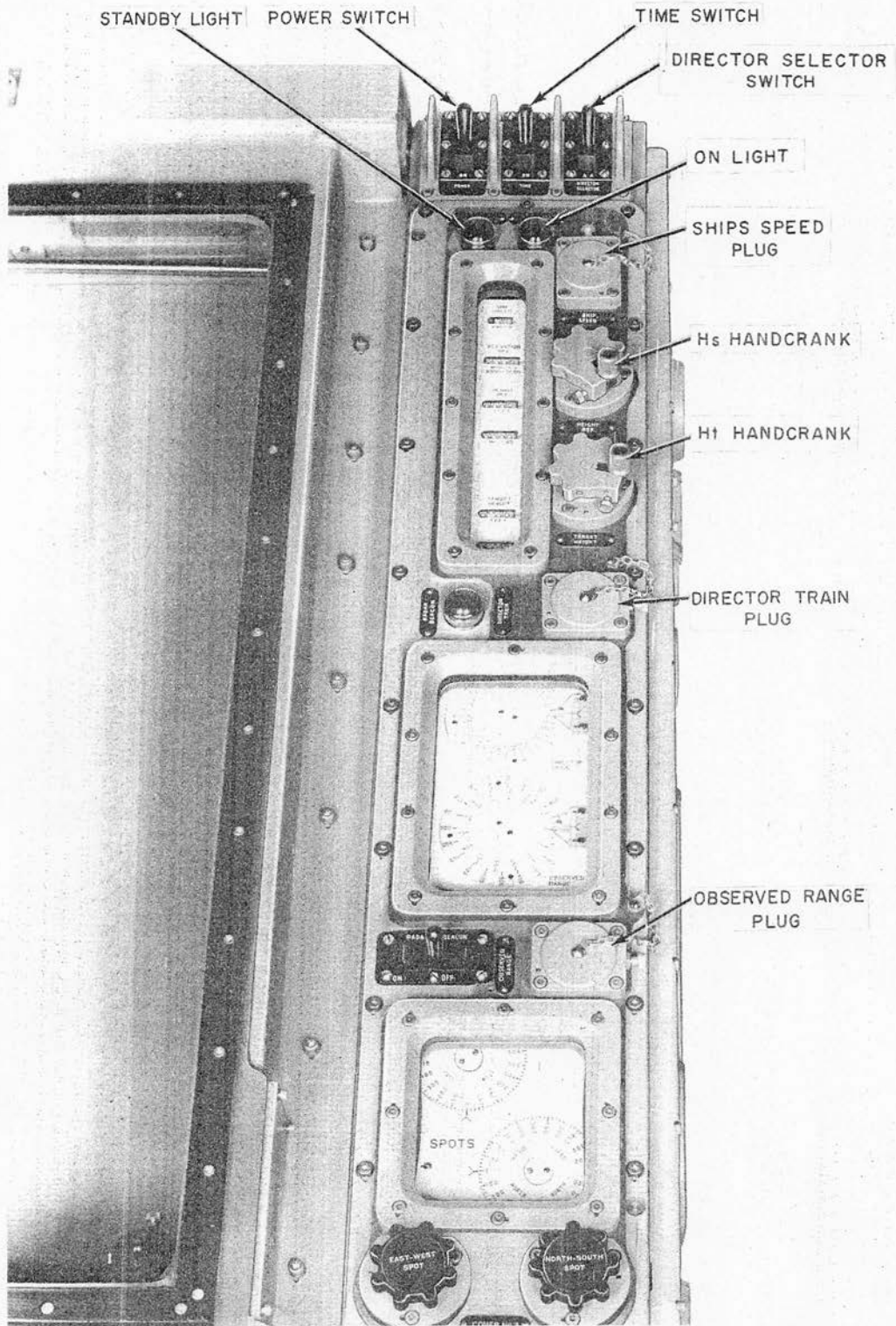

Figure 7. Controls on Top of Computer Mk 48 Mod 1

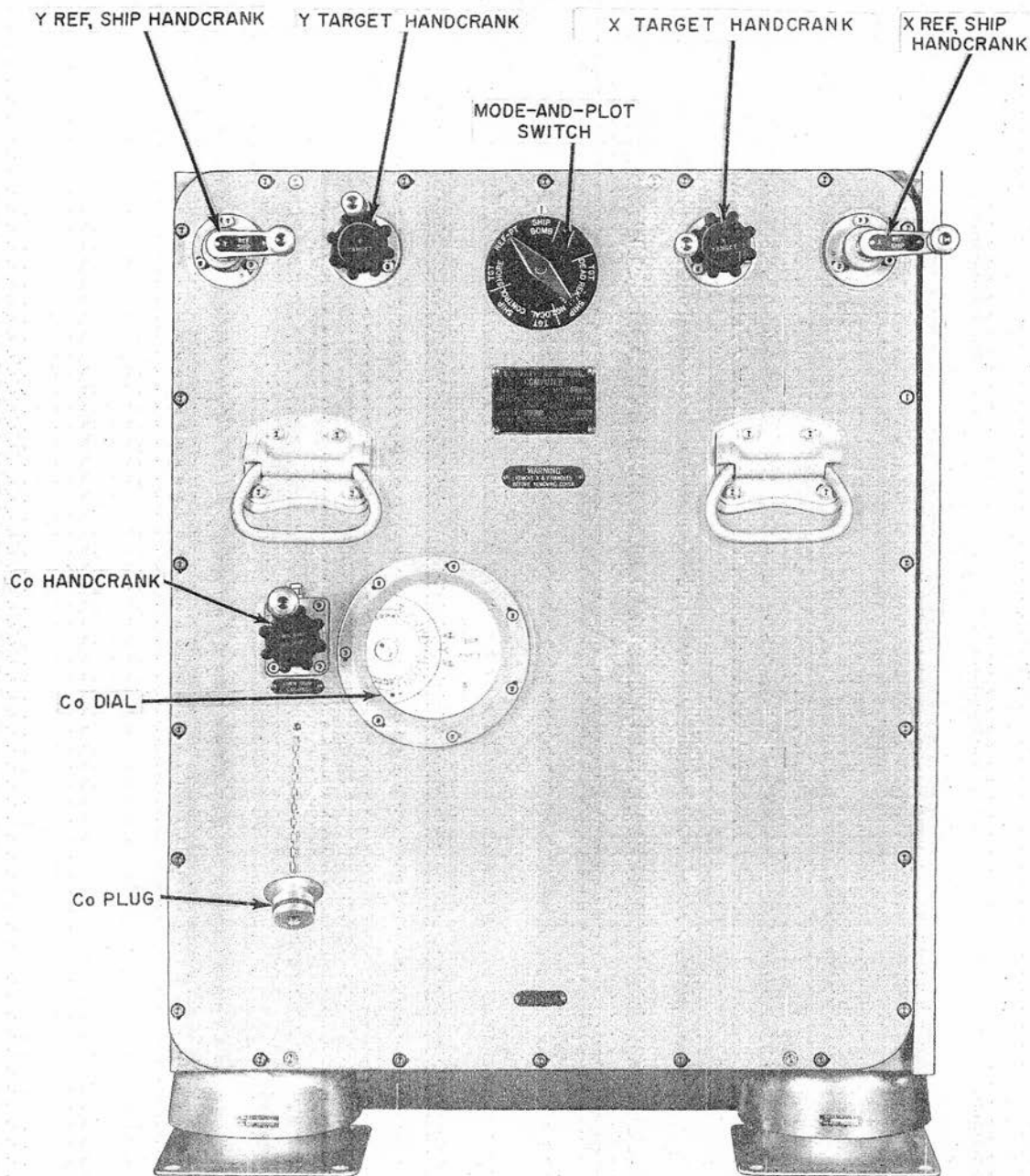

Figure 8. Controls on Front of Computer Mk 48 Mod 1

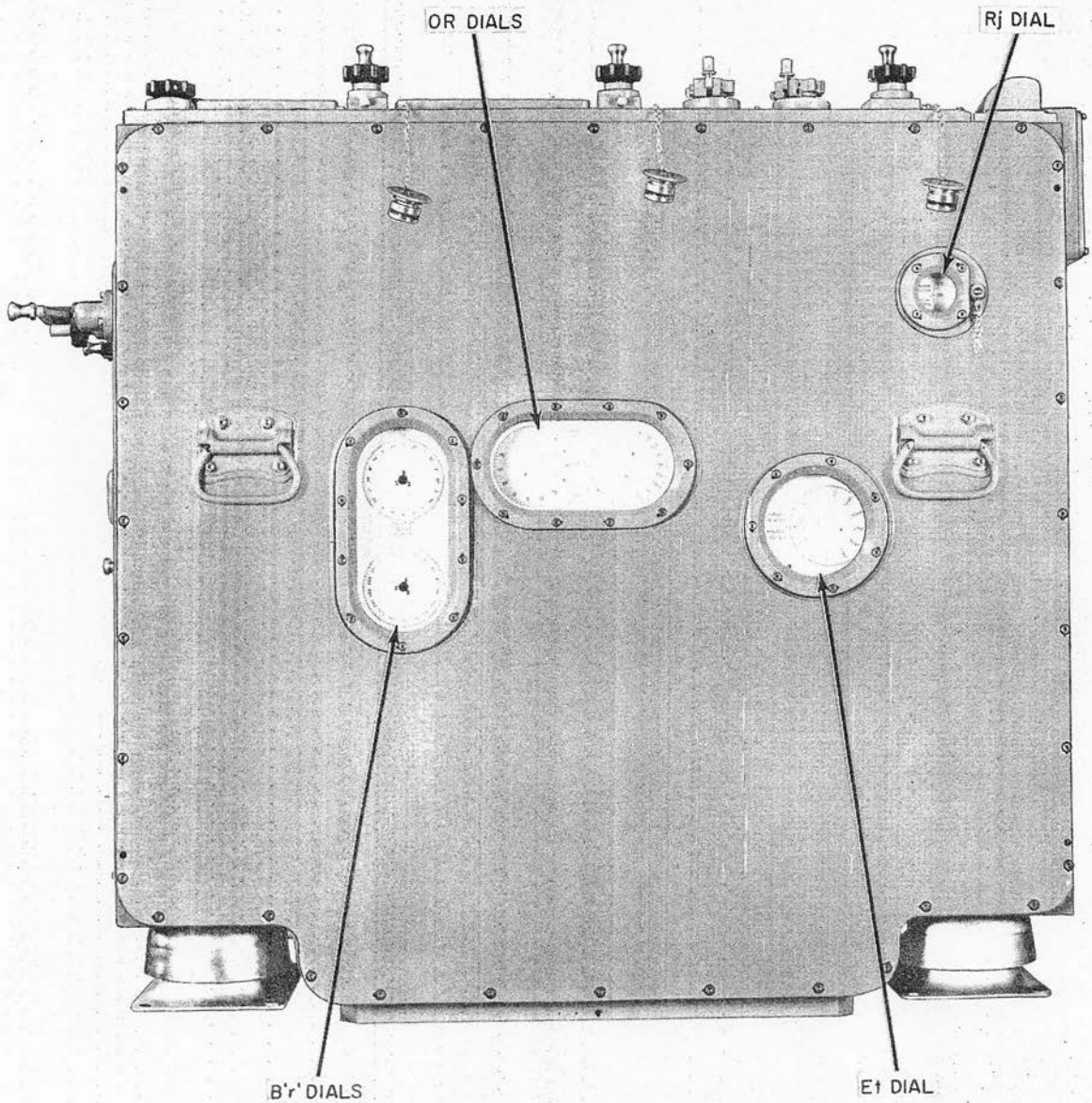

Figure 9. Dials on Right Side of Computer Mk 48 Mod 1

SCALE FACTOR COUNTER      SCALE FACTOR HANDCRANK      SCALE CHANGE PUSH BUTTON

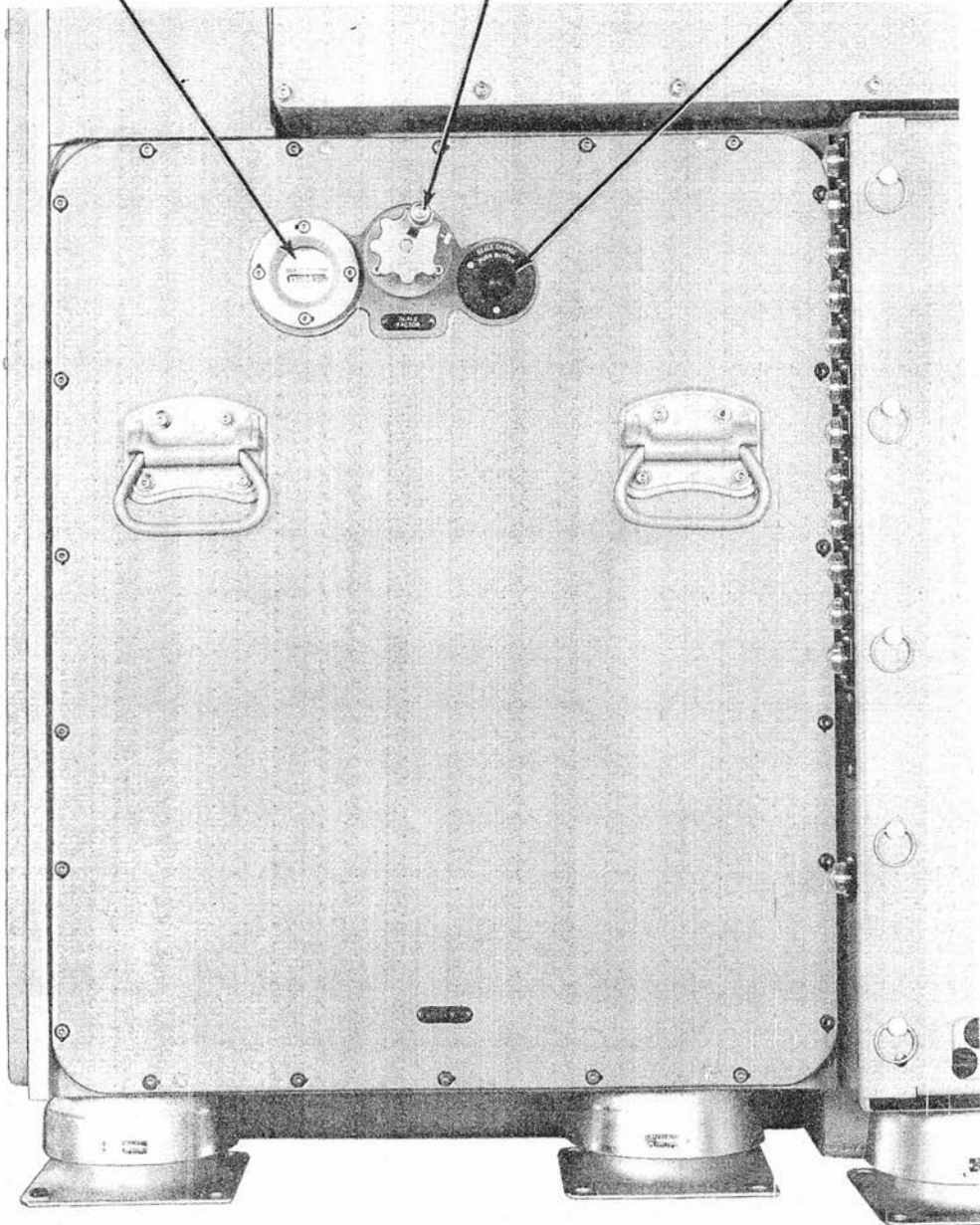

Figure 10. Computer Mk 48 Mod 1, Mechanical Section, Rear View

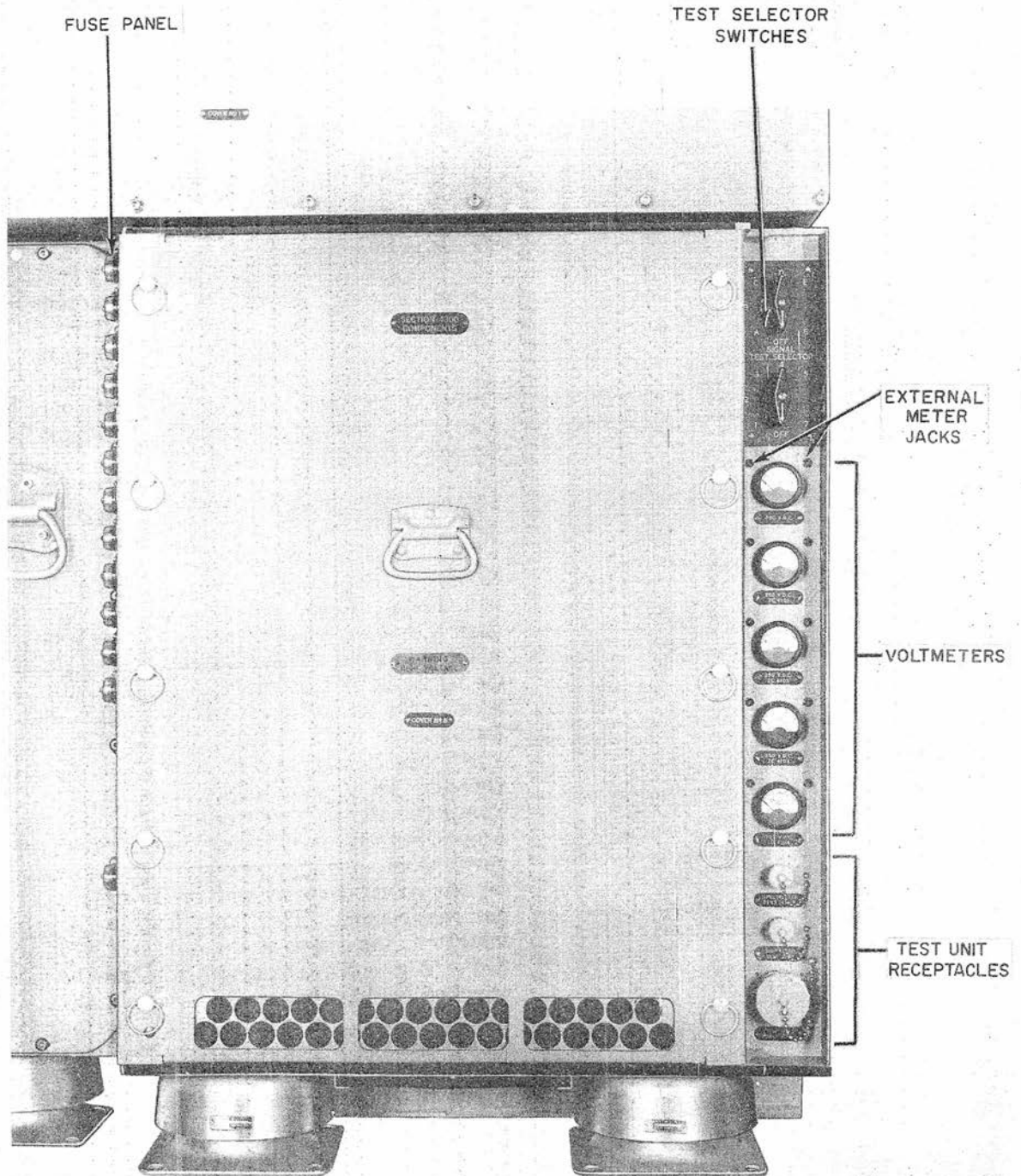

Figure 11. Computer Mk 48 Mod 1, Electronic Section, Rear View

North-south position of target, $Y_t$	Train control, $Co + jB'r' - jB$ (2-axis) or $Co + jB'r$ (3-axis)
East-west spot, $X_j$	
North-south spot, $Y_j$	Level, $L'$ (2-axis) or $L$ (3-axis)
Radar beacon delay spot, $R_j$	Cross level, $Z_d$ (3-axis)
Scale factor	Level and function of cross level, $L$ + $Z_d/30$ (3-axis)

## Automatic Inputs

Ship speed, $So$
Ship course, $Co$
Range, $R$
Director train, $B'r'$ (2-axis) or $B'r$ (3-axis)
Offset level, $OL'$ (2-axis) or $OL$ (3-axis)
Offset cross level, $OZh$ (2-axis) or $OZd$ (3-axis)

## Test Inputs (Manual)

Ship speed, $So$
Ship course, $Co$
Range, $R$
Director train, $B'r'$ , or $(B'r)$

## Electrical Outputs (by synchro transmission)

Range to target, $OR$
Target elevation, $Et$
Increments of generated range, $\Delta cR$
Horizontal Parallax, $Ph$ (3-axis)
Offset relative target bearing (director train to target), $OB'r'$ (2-axis) or $OB'r$ (3-axis)

## OPERATING LIMITS

The computer mechanisms are protected against damage from overruns by limit stops that engage before the limit of travel of their related mechanisms is reached. The various limit stops, their limits of operation, and the quantities affected are shown in table 1.

## TRANSMITTER AND RECEIVER SYNCHROS

The synchro units used in Computer Mk 48 Mod 1 are listed in table 2. Table 2 includes a "speed" column, or synchro shaft value per revolution. Depending on whether the Mk 37 Gun Director drive is of the Arma or Amplidyne type, the quantities level, plus a function of cross level ( $L + Z_d/30$ ), and train control, ( $Co + jB'r' - jB$ ), are transmitted at either of two speeds. As manufactured, the gearing of Computer Mk 48 Mod 1 is for the Amplidyne director drives (10 degrees per revolution). Change gears are furnished for the Arma director drives (5 degrees per revolution). When the computer is installed, the speed of the ( $L + Z_d/30$ ) and ( $Co + jB'r' - jB$ ) transmitters should be checked for agreement with the gun director receivers, and the gears in the computer changed if necessary (see chapter 6).

The transmitters for cross level ( $Z_d$ ) and level plus a function of cross level ( $L + Z_d/30$ ) do not enter into MB operation.

Table 1  
LIMIT STOPS

Limit Stop No	Quantity	Limits
L-1	Yp	0-32.8 in
L-2	Xp	0-32.8 in
L-3	Yj	±1000 yds
L-4	Et	2000'-3200' (0 to 20°)
L-5	Hs	0-5000 ft (0-1524 meters)
L-6	Ht	0-5000 ft (0-1524 meters)
L-7	Es	2000'-3800' (0 to 30°)
L-8	OR	500-50,000 yds
L-9	Xj	±1000 yds
L-10	L' (MB) or L (AA)	±25°
L-11	Zd (AA only)	±25°
L-12	OL' (MB) or OL (AA)	±25°
L-13	OZh (MB) or OZd (AA)	±25°
L-14	jOB'r' -jB'r' (MB) or jOB'r -jB'r (AA)	±20°
L-15	jOB'r' (MB) or jOB'r (AA)	±20°
L-16	jB	±15°
L-17	Ph	±12°
L-18	So	0-55 kn
L-19	R	500-50,000 yds
L-20	Scale factor	1:10,000-1:100,000

Table 2  
TRANSMITTER AND RECEIVER SYNCHROS

Function	Symbol		Type	Quan	Element	Speed
	MB	AA				
Ship speed	So	(So)	5B	1	B4070	40/kn/rev
Ship course	Co	(Co)	1HCT	2	B4052, B4053	10°/rev, 360°/rev
Range	R	(R)	1HCT	2	B4050, B4051	2000 yds/rev 72,000 yds/rev
Director train	B'r'	(B'r)	1HCT	2	B4054, B4055	10°/rev, 360°/rev
Offset level	OL'	(OL)	1HCT	2	B4056, B4057	10°/rev, 180°/rev
Offset cross level	OZh	(OZd)	1HCT	3	B4058, B4059, B4060	5°/rev, 10°/rev, 180°/rev
Range tracking aid	$\Delta cR$	( $\Delta cR$ )	5HG	1	B4073	1000 yds/rev
Horizontal parallax		(Ph)	6HG	1	B4074	30°/100 yds
Range to target	OR	(OR)	5HG	2	B4062, B4063	2000 yds/rev, 72,000 yds/rev
Target elevation	Et	(Et)	5HG	1	B4061	360 mils/rev
Cross level		(Zd)	6HG	2	B4064, B4065	5°/rev, 180°/rev
Level	L'	(L)	6HG, 5HG	2	B4067, B4075	10°/rev, 180°/rev
Level plus function of cross level		(L + Zd/30)	6HGB	1	B4066	10°/rev or 5°/rev (per change-gears)

Table 2 (Cont'd)

## TRANSMITTER AND RECEIVER SYNCHROS

Function	Symbol		Type	Quan	Element	Speed
	MB	AA				
Offset relative target bearing	OB'r'	(OB'r)	6HG	2	B4068, B4069	10°/rev, 360°/rev
Train control	Co + jB'r' - jB	(Co + jB'r)	6HG, 5HG	2	B4071, B4072	5°/rev, 10°/rev

## MOTOR-GENERATOR SET

This unit supplies +350-volts DC to the 250-volt series voltage regulator, the tuning fork amplifier, and the servo amplifiers in the electronic section of the computer. From this unit, therefore, all the operating DC voltages of the computer are

derived. The motor-generator set is equipped with controls for starting, stopping, and functioning under varying conditions. The functions of the motor-generator controls are detailed in table 71. For complete details on the motor-generator set, refer to NAVSHIPS 363-0686.

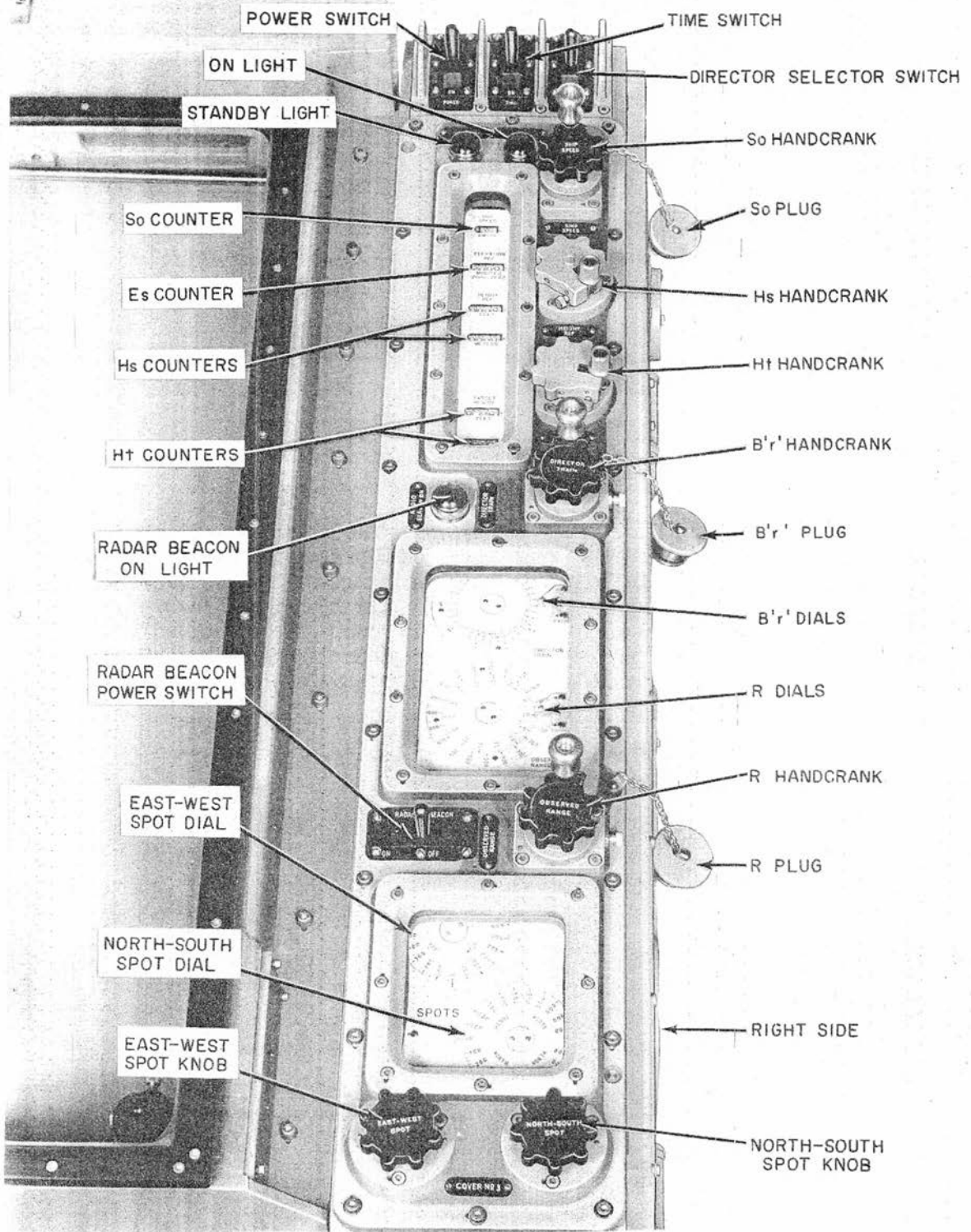

Figure 12. R, B'r', and So Handcranks Installed

## Chapter 3

## OPERATION

This chapter describes the essential features of the operating controls on Computer Mk 48 Mod 1, tables 3 through 6, and on the motor-generator set, and shows how these controls are used to operate the computer and motor-generator. Operation and use of the test unit is contained in chapter 5.

## OPERATING CONTROLS

The operating controls of the computer are handcranks, switches, and indicating devices. These controls are located on the top, front, rear, and right side of the computer. Some of the controls on the front are for monitoring purposes only, and some on the rear are for test purposes.

The storage shelf located near the computer is used to hold the ship speed, ship course, director train, and observed-range handcranks during automatic operation; sealing plugs are provided for plugging the handcrank holes in the covers of the computer, figure 7. When values of these functions are set into the computer for testing purposes, the plugs may be removed and the handcranks installed for manual operation, figure 12. When the handcranks are not in use, the plugs should be kept in place. In circumstances requiring intermittent use of the handcranks, the handcrank assemblies may be partially withdrawn and locked in the unmeshed position by engaging the locking pin in a second hole.

## TEST CONTROLS

In addition to the operating controls already listed, five voltmeters, a pair of test-selector switches, three test unit connecting receptacles, and a panel of indicator-type fuses are mounted on the rear of the electronic section of Computer Mk 48 Mod 1, figure 11.

Each voltmeter is calibrated to indicate percentage (from 0 to 120) of the nominal value listed on the legend plate beneath it. These voltmeters are used to give a rough indication of the operation of the motor-generator set and voltage regulators. The terminals of each meter are brought out to the panel jacks so that an external voltmeter can be connected for taking exact readings. From top to bottom, the meters indicate the outputs of the motor-generator set, the three 250-volt voltage regulators, and the -105-volt regulated power supply; the legend plates are marked and the meters indicate as follows:

<u>Legend Plate</u>	<u>Meter Indication</u> (Approximate)
350 V. D. C.	Reading of 100 percent indicates motor-generator set is delivering +350 v DC to computer.
250 V. D. C. ZC4101	Reading of 100 percent indicates voltage regulator ZC4101 is delivering +250 v DC.

Table 3

## CONTROLS ON TOP PANEL OF COMPUTER MK 48 MOD 1

(figures 7 and 12)

Device	Function
POWER switch	With 60-cycle power available and the power supply ON as later described, supplies all electrical components except synchros. At STANDBY, the heaters of all tubes are energized, the -105 v supply is available, and the fan operates; no computing or plate voltages are supplied. At ON, all units are energized, provided the switch has been at STANDBY for at least 30 seconds. Otherwise there will be a 30-second time delay before all circuits are operative. If the over-voltage relay in the power supply is actuated, movement of this switch from ON to STANDBY to ON will reset the relay. If it again kicks out, the source of the trouble must be located.
STANDBY (amber) light	Lights whenever POWER switch is at STANDBY or ON and the power-input line to Computer Mk 48 Mod 1 is energized.
ON (red) light	Lights whenever POWER switch is at ON and the power-input line is energized.
TIME switch	Operates when POWER switch is at ON. A two-position switch that turns time motor ON or OFF.
DIRECTOR SELECTOR switch	A two-position switch that sets-up the computer for operation with either the MB or AA director.
SHIP SPEED counter and handcrank	The counter shows the value of ship speed set into the computer. Ship speed can be set in manually by handcrank or received automatically by synchro. Handcrank is disengaged or removed for automatic operation, but So counter must be within 20 knots of true ship speed when receiver is energized or incorrect synchronization will result. Right-hand drum of counter graduated in 2/10 of a knot: one revolution equals 10 knots. Counter limits 0 to 55 knots. One revolution of handcrank equals 1.375 knots.

Table 3 (Cont'd)

## CONTROLS ON TOP PANEL OF COMPUTER MK 48 MOD 1

(figures 7 and 12)

Device	Function
ELEVATION REF counter	Indicates elevation of reference point as computed by the instrument; 2000 minutes equals zero elevation; maximum elevation 3800 minutes. Each graduation of right-hand drum equals 1 minute; one revolution equals 40 minutes. Primarily for test use.
HEIGHT REF counters and handcrank	Handcrank sets in map value of height of reference point in feet or meters. One revolution of handcrank equals 40 feet or approximately 12.2 meters. Counters indicate height of reference set in by handcrank. Each graduation of FEET counter equals 1 foot, one revolution equals 40 feet. Each graduation of METERS counter equals 0.2 meters, one revolution equals 10 meters.
TARGET HEIGHT counters and handcrank	Handcrank sets in map value of height of target in feet or meters. One revolution of handcrank equals 40 feet or approximately 12.2 meters. Counters indicate height of target set in by handcrank. Each graduation of FEET counter equals 1 foot, one revolution equals 40 feet. Each graduation of METERS counter equals 0.2 meters, one revolution equals 10 meters.
RADAR BEACON ON light	Yellow lamp glows when RADAR BEACON ON-OFF switch is at ON.
DIRECTOR TRAIN dials and handcrank	Dials indicate the value of director train set into the computer. Director train can be received automatically or set in manually by the handcrank, which is disengaged or removed for automatic operation. One revolution of handcrank equals 3 degrees. On ring dial each graduation equals 10 minutes, one revolution equals 10 degrees. On disk dial each graduation equals 10 degrees, one revolution equals 360 degrees.

Table 3 (Cont'd)

## CONTROLS ON TOP PANEL OF COMPUTER MK 48 MOD 1

(figures 7 and 12)

Device	Function
OBSERVED RANGE dials and handcrank	Dials indicate value of observed range set into computer. Observed range can be set in manually by the handcrank or received automatically. Handcrank is disengaged or removed for automatic operation. One revolution of handcrank equals 400 yards. Each graduation of ring dial equals 50 yards, one revolution equals 2000 yards. Each graduation of disk equals 1000 yards, one revolution equals 72,000 yards.
RADAR BEACON ON-OFF switch	A two-position switch. At ON, the radar-beacon delay spot is introduced and the RADAR BEACON ON light glows; at OFF, the spot potentiometer is disconnected and the light is off.
EAST-WEST and NORTH-SOUTH SPOT dials and knobs	The east-west and north-south spot knobs and dials are used to set spots into the computer. One revolution of either knob equals 550 yards. Each graduation on either dial equals 25 yards, one revolution equals 220 yards. Half of the east-west dial indicates for East spots, half for West. Half of the north-south dial indicates for North spots, half for South spots.

Table 4

## CONTROLS ON FRONT PANEL OF COMPUTER MK 48 MOD 1

(figure 8)

Device	Function
OWN SHIP COURSE dials and handcrank	Dials indicate value of own ship course set into computer. Removable handcrank can be used to set in own ship course manually. One revolution of handcrank equals 3 degrees. Each ring dial graduation equals 10 minutes, one revolution equals 10 degrees. Each disk dial graduation equals 10 degrees, one revolution equals 360 degrees.
Mode-and-Plot switch	An 8-position switch, used when setting chart coordinates, for firing without director, or when using computer as navigation aid. Eighth position of switch is OFF. For complete functional description of this switch, see chapter 4.
X or Y TARGET handcrank	These handcranks are used in conjunction with the plotter to crank in the values of the coordinates of target position as obtained from a chart, when mode selector switch is at SHORE BOMB TGT or LOCAL CONTROL TGT. These handcranks position the plotter index light at the map position of the target. Once cranked in, the values continue to be used to compute target for any position of mode selector other than the dead-reckoning positions. One revolution of either handcrank equals 1000 yards.
X or Y REF SHIP handcrank	These handcranks are used to crank into the computer the coordinate values of own ship or reference-point position, as obtained from the map on the plotter. These handcranks position the plotter index light at the map position of the reference point or own ship. The specific quantity cranked in is determined by the mode-and-plot switch position. One revolution of either handcrank equals 1000 yards. For a complete description of the mode-and-plot switch functions, refer to chapter 4.
SC-SA TEST and SC-SA NEON TEST switches (figure 43)	For testing the condition of the servo controls, servo amplifiers, computing amplifiers, and neon lights. Operation of these switches is covered in chapter 5, section 3.

Table 5

## CONTROLS ON RIGHT SIDE OF COMPUTER MK 48 MOD 1

(figure 9)

Device	Function
RELATIVE TARGET BEARING dials	Indicate computed value of relative target bearing. One revolution of fine dial equals 10 degrees, each graduation equals 5 minutes. One revolution of course dial equals 360 degrees, each graduation equals 5 degrees.
RANGE TO TARGET dials	Indicate computed target range. One revolution of fine dial equals 2000 yards, each graduation equals 50 yards. One revolution of coarse dial equals 72,000 yards, each graduation equals 1000 yards.
TARGET ELEVATION dial	Indicates computed value of target elevation. One revolution equals 1237.89 minutes, each graduation equals 10 minutes. Zero elevation at 2000 minutes.
RADAR BEACON DELAY YARDS dial and input	Indicates in yards value of range spot introduced to compensate for radar-beacon delay. Spot can vary from 100 to 400 yards; each dial graduation equals 10 yards. Spot is set in with adjustment screw under plug at side of dial.

Table 6  
CONTROLS ON REAR OF COMPUTER MK 48 MOD 1

(figure 10)

Device	Function
SCALE FACTOR counter	Indicates value of map scale in use with plotter, variable from 10,000:1 to 100,000:1. Only three left-hand drums of counter revolve. From left to right, drums indicate tens of thousands, thousands, and hundreds. Upper limit, 100,000:1, reads all ciphers.
SCALE FACTOR handcrank	When SCALE CHANGE PUSH BUTTON is pushed in, handcrank can be used to change scale ratio to agree with scale of chart on plotter. One revolution of handcrank changes scale by 1000:1.
SCALE CHANGE PUSH BUTTON	When button is pushed in, SCALE FACTOR handcrank engages gear line. When button is released, handcrank is disengaged from gear line.

<u>Legend Plate</u>	<u>Meter Indication</u> (Approximate)
250 V. D. C. ZC4102	Reading of 100 percent indicates voltage regulator ZC4102 is delivering +250 v DC.
250 V. D. C. ZC4103	Reading of 100 percent indicates voltage regulator ZC4103 is delivering +250 v DC.
-105 V. D. C. ZC4104	Reading of 100 percent indicates regulator power supply ZC4104 is delivering -105 v DC.

The TEST-SELECTOR switches and the connection facilities near the bottom of the panel are used to connect prescribed test circuit points within the computer to the

special test unit. A detailed description of the operation of the switches and the test unit is contained in chapter 5.

The fuse panel is equipped with sockets that have transparent covers for visual detection of blown fuses. A red indicator dot can be seen through these covers when a fuse has burned out. A cover plate at the lower end of the fuse panel provides access to a storage receptacle for spare fuses. For detailed information on the fuses, refer to table 24.

#### PLOTTER AND PROTRACTOR

##### Plotter

In shore bombardment the plotter is used as an indicator when setting target, reference point, or own ship position into

Computer Mk 48 Mod 1. In conjunction with the protractor, the plotter can be used to lay out target position in terms of range and bearing from own ship or from a spotter's position, or to lay out a new target from the old target position. It also may be used to measure set and drift. Although normally not required for the shore bombardment mode, the protractor may be used to establish safety zones and for similar measurement purposes.

The plotter index light projects the image of a cross mark through a chart mounted on its glass surface. As the TARGET and REF-SHIP handcranks move the projected cross mark to the target position and then to the reference point position (the order is unimportant), the relative positions of the target and the reference point with respect to a N-S E-W rectangular coordinate system are introduced into the computer (see chapter 4).

#### Protractor

This device consists essentially of a calibrated protractor and linear scale, supported by a parallel motion mechanism over the plotting surface, figure 13. The bracket supporting the mechanism has an adjustable pivot in the form of a knurled screw with a lock nut. This pivot, which permits raising and lowering of the protractor, can be adjusted to eliminate side-play or loosened to remove the mechanism. On each of the pivots of the parallel motion arms, a knob is provided for adjusting the friction of the pivot.

The protractor head is calibrated from 0 to 360 degrees in 1-degree graduations. A quarter turn (counterclockwise) of the PROT LOCK loosens the protractor scale so it can be rotated to align its zero graduation with North on the chart and plotter. With PROT LOCK in a locked position, the protractor scale maintains the alignment regardless of movement over the plotting area.

The witness plate (inner movable ring, figure 13) contains four indexes spaced 90 degrees apart. A quarter turn (counterclockwise) of the scale lock loosens the witness plate so it can be moved to any angular position against the protractor scale by turning the protractor hand knob. When locked in position, the protractor maintains the indexes in a fixed position with respect to the protractor scale.

For fine control of the witness plate, a vernier knob mounted on the hand knob can be engaged by swinging the vernier knob toward the center of the hand knob. The reverse action disengages the vernier for coarse control.

The 24-inch composite scale supplied with the equipment is designed for use with a computer scale factor of 25,000 or 50,000 to 1. It has two sets of range-time-speed calibrations from which the set and drift of own ship can be determined by measuring the directional distance of deviation from course during a fixed-time interval. The scale is illustrated in figure 13. The chuck on the 24-inch composite scale is friction-fitted to the tapered slot of the protractor scale arm. The composite scale moves in correspondence with the witness plate.

#### SHORE-BOMBARDMENT AUXILIARY SWITCHBOARD

An auxiliary switchboard installed near the computer connects the main switchboard and the computer. This auxiliary switchboard permits connecting the computer to the director, gun order computer, and stable element selected at the main switchboard, or bypassing the computer entirely. The DIRECTOR SELECTOR switch on the computer sets up the computer for operation with either a two-axis (MB) or a three-axis (AA) system. Once the system is selected at the main switchboard, Computer Mk 48

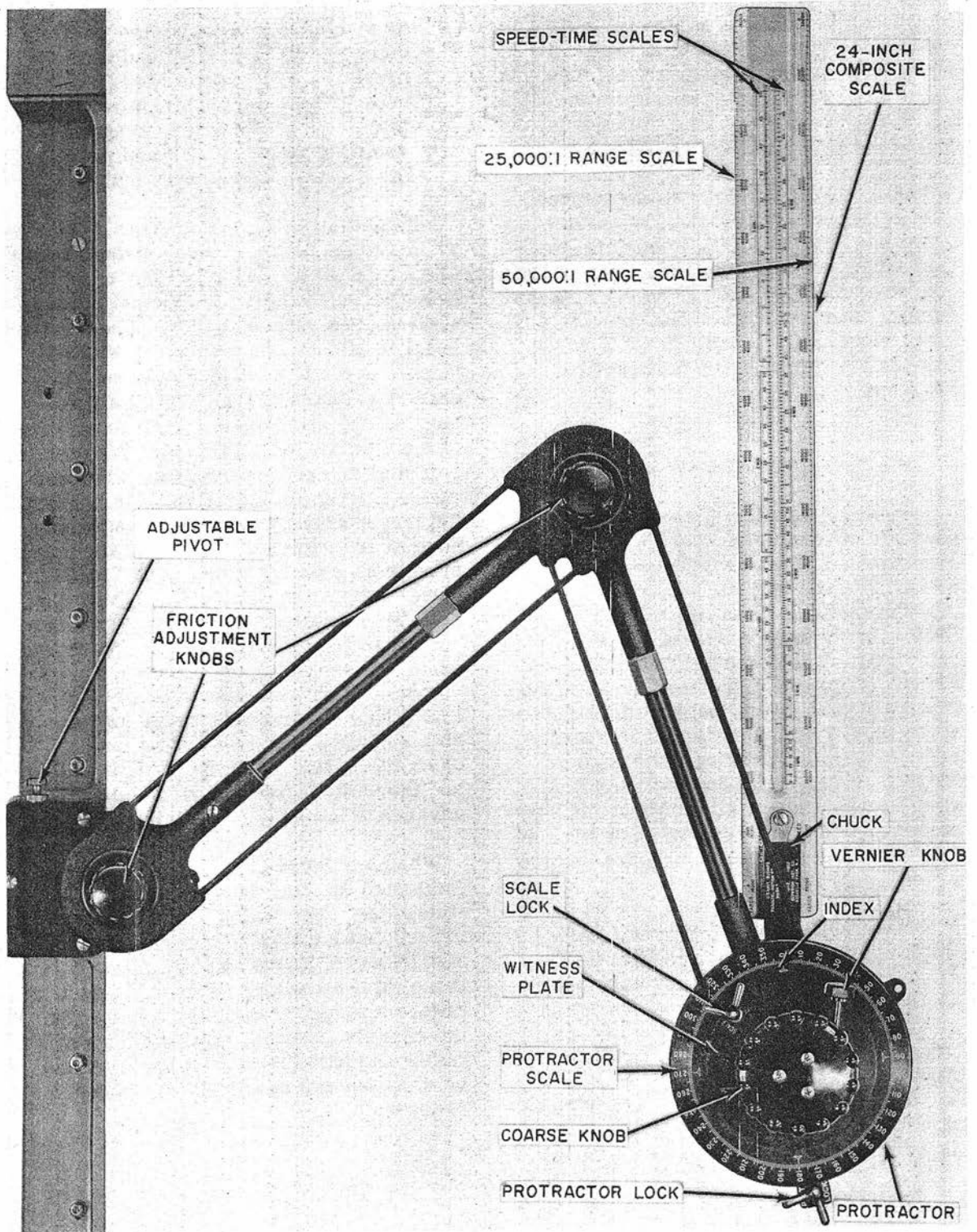

Figure 13. Parallel Motion Protractor

Mod 1 can be connected into the selected system for indirect fire by means of the shore-bombardment auxiliary switchboard.

### MOTOR-GENERATOR CONTROLS

The motor-generator set is equipped with controls for operating the motor-generator and for maintaining safe operation under varying loads, for varying the operating method, and for monitoring the output. The functions of the controls are described briefly in table 7. For complete information, refer to NAVSHIPS 363-0686.

### OPERATING PROCEDURE

When the computer is secured, all power is off and the synchro signals are disconnected at the switchboard. In STANDBY, the only circuits energized are those of the tube filaments, STANDBY light, -105-v supply, blower, and time-delay unit. The computer can be left in STANDBY condition indefinitely. All the tubes will then be lit, but the plate-supply voltages will not be sufficient to operate the computer. Throwing the computer POWER switch to ON immediately completes application of all power to the computer, provided the computer has been at STANDBY for at least 30 seconds and the motor-generator is ON.

**CAUTION:** Do not turn the computer POWER switch to ON unless the motor-generator has been energized.

If the computer POWER switch is thrown from OFF directly to ON, application of plate voltages is delayed for 30 seconds by a time-delay relay, allowing time for the tube filaments to warm up.

**CAUTION:** If it becomes necessary to switch the motor-generator from automatic to manual operation,

or vice versa, first put the computer at STANDBY and then press the motor-generator OFF button, before switching operation. When restarting, keep the computer at STANDBY and press the motor-generator ON button.

The plotter will accommodate a chart up to 35-inches square. Since standard charts are 35 inches x 45 inches, they must be cropped judiciously. The actual plotting area is 32.8-inches square. The selected chart is attached to the plotter with adhesive tape. For rough alignment, the center meridian of the chart is aligned with the top and bottom center index lines of the plotter, see figure 14. In order to refine alignment, charts should be readjusted so that the meridian in or nearest to the target area is parallel to the North-South axis of the plotter. This alignment may be checked by using the X TARGET handcrank to move the index light to the selected meridian. If the chart is aligned correctly, the Y TARGET handcrank then will move the index light along the meridian. Be sure that the SCALE FACTOR counter reads the same value as the chart scale. For prearranged operations, the chart should be installed and the scale factor adjusted well in advance of the scheduled firing.

When any large errors that cannot be attributed to other sources occur while firing, they may be considered map errors and the EAST-WEST and NORTH-SOUTH SPOT knobs can be used to correct these discrepancies. When shifting to a different target area on the chart, or if the chart is changed, any existing EAST-WEST and NORTH-SOUTH spots should be removed and new ones introduced if necessary.

Table 7

## CONTROLS ON MOTOR-GENERATOR SET

Device	Function
ON-EMERGENCY RUN and OFF switches	Two momentary-contact pushbutton switches; the ON-EMERGENCY RUN button, energizes the motor of the motor-generator; the OFF button de-energizes the motor-generator. By pressing and holding in the ON-EMERGENCY RUN button, the motor-generator can be kept operating despite the action of an overload relay, which otherwise would de-energize the motor-generator if the maximum safe load were exceeded.
RESET switch	A pushbutton momentary-contact switch to reset the overload relay if the overload relay has de-energized the motor-generator.
AUTOMATIC-MANUAL switch	Ordinarily, set at AUTOMATIC position. MANUAL position used if voltage regulator in motor-generator set fails to function properly. It then is necessary to regulate the output by adjusting the FIELD RHEOSTAT.
FIELD RHEOSTAT control	May be adjusted (with AUTOMATIC-MANUAL switch in MANUAL position) to obtain 350-v DC output voltage if regulator is faulty.
DC voltmeter	Indicates output voltage of motor-generator.

## Initial Operating Setup

The computer and motor-generator are put in operation by following the step-by-step procedure of table 8.

## SHORE-BOMBARDMENT Mode

This is the primary mode of operation of Computer Mk 48 Mod 1. After completing the initial operating setup of table 8, proceed as outlined in table 9.

If the inputs from the director to Computer Mk 48 Mod 1 and the outputs from

this computer to the gun order computer are steady and smooth, correct target location data is being transmitted to the gun order computer. Relative target bearing, range to target, and target elevation are shown on the dials on the right side of Computer Mk 48 Mod 1. No correction for set and drift need be made at the gun order computer, since the director is continuously establishing true ship position with respect to the reference point. When the gun order computer has a solution for the problem, firing may begin.

CENTERING INDEX

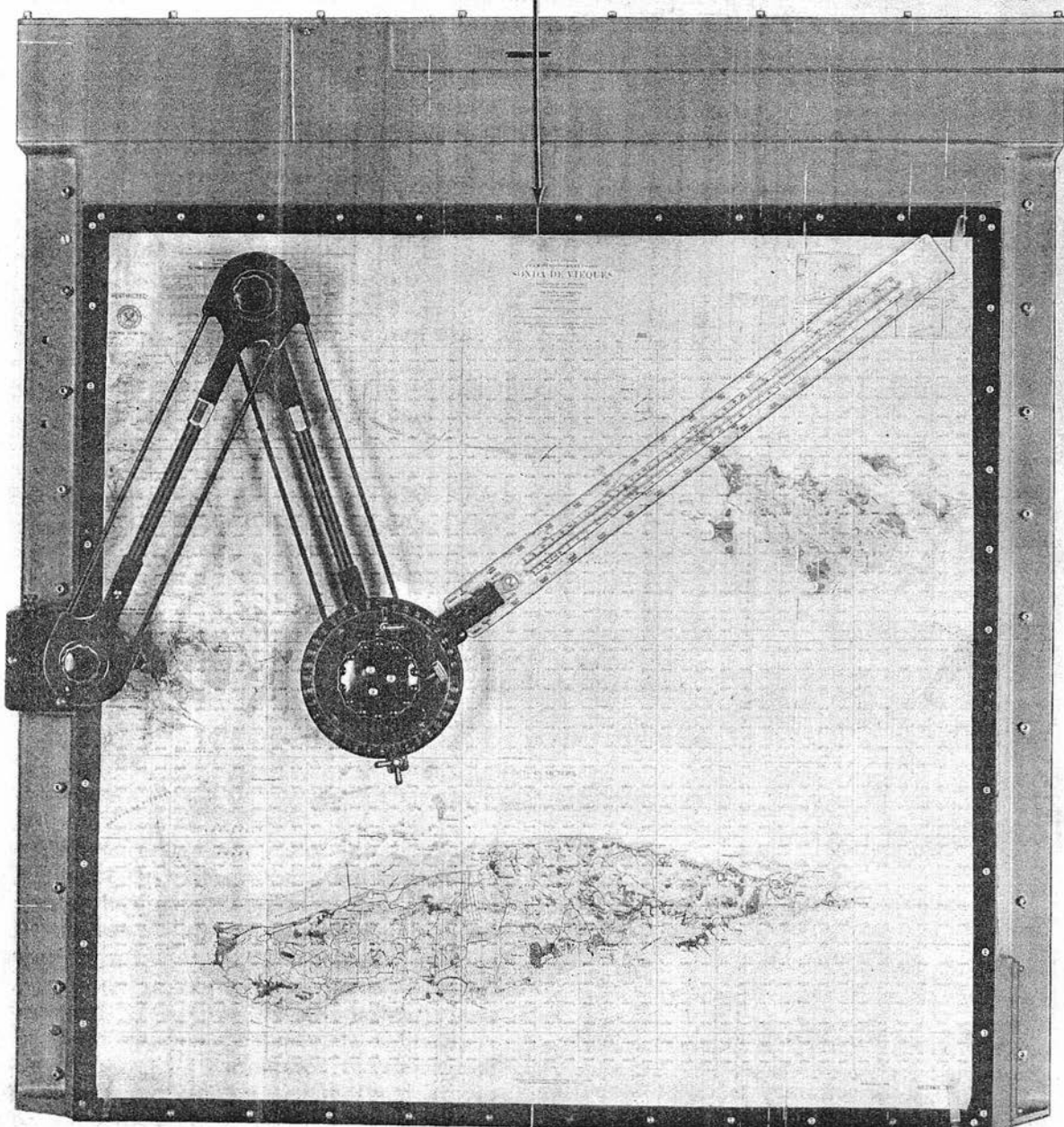

CENTERING INDEX

TAPE

Figure 14. Transverse Mercator Projection Chart Mounted on Plotter

Table 8

## INITIAL OPERATING SETUP

Device	Position or Setting
*AUTOMATIC-MANUAL switch of motor-generator	AUTOMATIC
POWER switch of computer	STANDBY
DIRECTOR SELECTOR switch	MB (Range Keeper Mk 8) or AA (Computer Mk 1A) in accordance with units selected at main switchboard.
Auxiliary switchboard switches	Connect computer synchro inputs and outputs for associated director, gun order computer, and stable element in accordance with units selected at main switchboard.
TIME switch	ON
SCALE FACTOR handcrank	Set counter to show same scale value as chart on plotter.
TEST SELECTOR switches	OFF
SPOT knobs	Rotate until dials are at zero (assuming no known error exists in chart).
Co, B'r', R, So handcranks	Removed and stored or disengaged.
*ON-EMERGENCY RUN switch of motor-generator	Press and then release button.
*DC voltmeter of motor-generator	Should indicate 350 volts.
POWER switch of computer	ON
DC voltmeters of computer (5)	Should indicate approximately 100 percent.

Table 8 (Cont'd)

## INITIAL OPERATING SETUP

Device	Position or Setting
OWN SHIP COURSE dials	Should show actual value of own ship course.
SHIP SPEED counter	Should show actual ship speed.
DIRECTOR TRAIN dials	Should show actual value of director train.
OBSERVED RANGE dials	Should show actual value of observed range.
S.C. -S.A. switch (figure 43)	SERVO CONTROL TEST.
S.C. NEON-S.A. switch (figure 43)	SERVO CONTROL NEONS. All ZB neons should glow. Re- place defective lamps.
S.C. -S.A. switch	AMPLIFIER TEST
S.C. NEON-S.A. switch	AMPLIFIER NEONS. All ZAS and ZAC neons should glow. Replace defective lamps.
S.C. -S.A. switch	<p>S.C. TEST. If any servo-control element is defective, its related neon light in group ZB will glow.</p> <p>S.A. TEST. If any servo-amplifier element is defective, its related neon light in group ZAS will glow.</p> <p>OPERATE. Observe the neon lights in group ZAC during operation of the computer. If any light glows steadily, the first stage of the corresponding amplifier is defective. Intermittent flashing is due to transient conditions and should be ignored.</p>

\* Remotely located equipment. Refer to NAVSHIPS 363-0686.

After firing begins, spot corrections may be ordered in the E-W N-S plotter coordinates. These should be set in by using the EAST-WEST and NORTH-SOUTH SPOT knobs. These knobs may also be used to correct for any large firing errors due to possible map discrepancies. When the target area is large, the X and Y TARGET handcranks are used to move the plotter index light about (and consequently the point of impact) within the target area.

Since set and drift must be known for operation in local control, these may be ascertained in advance while operating in the shore bombardment mode. To determine set and drift, the following should be done:

1. At intervals shown on the protractor speed-time scale applicable to the chart, set the mode-and-plot switch at SHORE BOMB SHIP. Mark ship's actual position on the chart.
2. For the same time intervals, plot ship's theoretical position as it changes, using ship course, Co, and speed, So. Assume that the ship's position at the beginning of each period is that shown by the plotter light. Use the appropriate protractor speed-time scale to plot this theoretical position on the chart. Note the ship's theoretical position at the end of each period.
3. Use the same time-speed scale to measure the direction and distance from a theoretical position of the ship to its corresponding true position. These measurements give set in degrees and drift in knots.

#### Changing from SHORE BOMBARDMENT Mode to LOCAL CONTROL Mode

If the reference point is about to become obscured (while in the shore bombardment mode) the following must be done:

1. Set mode-and-plot switch at SHORE BOMB SHIP. The plotter index light now should be over own ship position. Mark this position on the map.

2. In rapid succession, turn the time motor off; turn the mode-and-plot switch to LOCAL CONTROL SHIP; turn the time motor on again; and relocate the plotter index over the previously marked own ship position using the X and Y REF SHIP handcranks. Note movement of the index as it follows own ship movement, and estimate a correction that will compensate own ship plot for motion lost during the operations described in the previous sentence. Introduce this correction through the X and Y REF SHIP handcranks.

#### LOCAL CONTROL Mode

When an obscured target's range and bearing are known and no reference point is available, the firing problem can be handled by the gun order computer working in regenerative or local control. However, if only the target and ship map locations are known, Computer Mk 48 can be used to compute target range and bearing for the gun order computer. In the LOCAL CONTROL mode, corrections for set and drift must be set into the gun order computer. Computer Mk 48 first must be brought into operating condition as described in table 8, and then the procedure described in table 10 should be followed.

To change targets while in LOCAL CONTROL, put the mode-and-plot switch at LOCAL CONTROL TGT. Use the X and Y TARGET handcranks to position the plotter index light at the new target. Return the mode-and-plot switch to LOCAL CONTROL.

#### SHIP-TO-SHIP Mode

The purpose of the computer during this type of operation is to supply, as a

Table 9

## SHORE BOMBARDMENT MODE OF OPERATION

Device	Position or Setting
HEIGHT REF handcrank	Rotate until HEIGHT-REF counter shows reference height value obtained from chart contour lines.
ELEVATION REF counter	Should show elevation of reference point.
TARGET HEIGHT handcrank	Rotate until TARGET HEIGHT counter shows target height obtained from chart contour lines.
Mode-and-Plot switch	<p>Set switch at following positions in sequence listed; operate handcranks as directed for each switch position:</p> <ol style="list-style-type: none"> <li data-bbox="498 751 1166 839">1. SHORE BOMB REF-PT. Rotate X and Y REF SHIP handcranks to bring plotter index light to reference point on map.</li> <li data-bbox="498 874 1244 963">2. SHORE BOMB TGT. Rotate X and Y TARGET handcranks to bring plotter index light to target on chart.</li> </ol>

Table 10

## LOCAL CONTROL MODE OF OPERATION

Device	Position or Setting
TARGET HEIGHT handcrank	Rotate until TARGET HEIGHT counter shows target height.
Mode-and-Plot switch	<p>Set switch at following positions in sequence listed; operate handcranks as directed for each switch position:</p> <ol style="list-style-type: none"> <li data-bbox="487 1504 1217 1592">1. LOCAL CONTROL TGT. Rotate X and Y TARGET handcranks to bring plotter index light to target on chart.</li> </ol>

Table 10 (Cont'd)

## LOCAL CONTROL MODE OF OPERATION

Device	Position or Setting
	2. LOCAL CONTROL SHIP. Rotate X and Y REF SHIP handcranks to bring plotter index light to own ship position.

secondary source of target motion, information to the active gun order computer. Computer Mk 48 Mod 1 receives the usual automatic inputs from the gun director, stable element, gyro compass, and pitometer log. However, in ship-to-ship operation the gun director and stable element are connected directly to the gun order computer, since the mode involves direct fire.

The initial operating setup is outlined in table 8. (If desired, blank paper may be used instead of a chart.) The following additional steps are then performed:

1. Align zero-degree on the protractor scale with the north index of the plotter. Tighten PROT LOCK.
2. Select an area for plotting on the paper that affords the most time before own ship and target would move off the paper.
3. Set the scale-shift counter at 25,000:1, if the range is not expected to exceed 16,000 yards; or at 50,000:1, if the range is to be greater than 16,000 yards.
4. Turn the mode-and-plot selector switch to DEAD REK'NG-TARGET. Travel of the plotter index light represents target.

5. Mark target position and exact time on the paper at regular one-minute intervals.

6. Determine target speed directly in knots by measuring the length of the developed vector with the time-speed section of the composite scale. Use the calibrations that correspond with the elapsed time of the developed vector and the scale factor in use.

7. Align the composite scale with the vector, and read target course on the protractor scale.

8. If desired, the own ship vector can be plotted between target-plot intervals by turning the mode-and-plot switch to DEAD REK'NG-SHIP and marking the ship position on the paper.

## DEAD RECKONING Mode

To start a dead-reckoning plot based on the chart location of a known landmark, complete the initial operating setup outlined in table 8. In this case, the "target" is the known landmark. After the director gets on the "target," the following steps are performed:

1. Turn the mode-and-plot selector switch to DEAD REK'NG-TARGET.

2. By means of the REF-SHIP handcranks, position the index light at the landmark location on the chart.

3. Turn the mode-and-plot selector switch to DEAD REK'NG SHIP.

4. The index light now will represent and plot own ship position. The plot can be marked on the chart at regular intervals.

If the plot is to be initiated from a known chart position of own ship instead of a landmark, omit the preceding steps 1 and 2, and proceed with step 3 using the REF-SHIP handcranks to position the index light at present own ship position on the chart.

## SPECIAL MODES OF OPERATION

### Manual Plotting

The protractor affixed to the plotter can be used for laying out either own ship or target position from information in terms of range and bearing.

When laying out own ship position on a chart with the protractor, target position on the chart, range, and either director train or relative bearing must be known. The procedure for finding own-ship position is as follows:

1. Add ship course to the known value of director train or relative bearing to obtain true bearing; turn the protractor knob so that the protractor reads this value of bearing.

2. Adjust the protractor's position so that the point on the scale edge, that has the same value as the known range, is directly over the target location on the chart. (The composite scale calibrations used must have the same scale factor as the chart in use.)

3. Note the location on the chart over which the zero point on the scale edge falls. This location is own ship position.

When laying out target position on a chart, own ship position, range, and either director train or relative bearing must be known. The procedure for laying out target location is as follows:

1. Add ship course to the known value of director train or relative bearing to obtain true bearing; turn the protractor knob so that the protractor reads this value of bearing.

2. Adjust the position of the protractor so that the zero point on the scale edge is directly over own ship location on the chart. (The composite scale calibrations used must have the same factor as the chart in use.)

3. Note the location on the chart over which the point on the scale edge, having the same value as the range, falls. This location is the target position on the chart.

### Area Fire

Using Computer Mk 48, indirect fire on an area of known dimensions and location on the chart can be accomplished with aerial or shore-party spotting. The index light is set near one corner of the target area as marked out on the chart, with the mode-and-plot switch at SHORE BOMB TGT. When the point of impact is spotted to coincide with the index light position on the chart, the X and Y TARGET handcranks can be operated to saturate the area as required for the particular type of target. (Chart errors are corrected by the EAST-WEST and NORTH-SOUTH SPOT knobs. System and ballistic errors may be corrected by introducing range and deflection spots at the gun order computer.) If spotting is unavailable, the bombardment

should overlap the area enough to nullify possible chart or system errors.

#### Firing on Roads and Runways

This type of firing deals with the problem of destroying roads, runways, or truck convoys. Using aerial or shore-party spotting, set the index light at the point on the chart where bombardment is to begin; apply range spots at the gun order computer as necessary to straddle the road with fire. With the X and Y TARGET handcranks, move the index light along the road as represented on the chart, applying any additional range spots required to keep the mean point of impact centered on the road.

#### PARALLAX CORRECTION

In direct fire, the train output of Gun Director Mk 37 is corrected for horizontal parallax by combining with it an appropriate fraction of the unit parallax correction transmitted by Computer Mk 1A. In indirect fire, however, the Computer Mk 1A unit parallax is based on the target coordinates and can be used only for correcting the gun turrets. The unit parallax receiver in the director must be connected to the transmitter in Computer Mk 48 which transmits a correction based on range and bearing of the reference point.

In the two-axis main battery directors, the parallax correction is computed, or partially computed, by director mechanisms from inputs that normally pertain to the target: director train and range or a function of range. For indirect fire, these inputs must be derived for the reference point as outlined in the following paragraphs.

In direct fire, Gun Director Mk 34 receives the sight angle,  $V_s$ , from the range keeper.  $V_s$ , shown on a dial in the director, is set manually into the train-

parallax computing mechanism. For indirect fire, the sight angle to the reference point must be supplied instead. This may be accomplished by compiling a table listing reference-point range against sight-angle values. From this table the sight angle corresponding to a given range may be ascertained and set into the train parallax computing mechanism. Range to reference point is, of course, available in the director.

Gun Director Mk 38 uses the target-range input to compute the parallax correction for direct fire. In indirect fire, therefore, the range to the reference point is set manually into the parallax mechanism.

In direct fire, Gun Director Mk 54 automatically receives parallax range (the reciprocal of range) and computes the parallax correction. For indirect fire, the reference point range is introduced manually and automatically converted to parallax range by the relation of input dial calibration to receiving mechanism.

A summary of the way in which parallax correction is handled in various directors is given in table 72.



Figure 15. Horizontal Quantities Obtained from Plotter and Map

## Chapter 4

## THEORY AND FUNCTIONAL DESCRIPTION

## Section 4.1—Theory

## GEOMETRIC QUANTITIES

The distinction between reference point and target in indirect fire involves new geometric quantities. These do not exist in the direct fire problem, where the point being sighted is the target itself. The new quantities are:

## Quantities Obtained from Plotter and Map

Reference point and target locations,  $(X_a, Y_a)$  and  $(X_t, Y_t)$ , are obtained from a map on which both are shown. The map is laid out on the plotter of Computer Mk 48 Mod 1. An X-Y rectangular coordinate system is used, with the Y axis north-south, figure 15. The origin of the coordinate system is, arbitrarily, the center of the computer plotting table. It is emphasized that the X and Y quantities represent reference point, target, and ship positions, not components of ship or target velocity.  $X_a$  and  $Y_a$  locate the reference point;  $X_t$  and  $Y_t$  locate the target; and  $X_o$  and  $Y_o$  locate the ship. ( $X_o$  and  $Y_o$  are not used in the SHORE BOMBARDMENT mode.) These quantities are introduced into the computer by using handcranks to move an index light under the glass plotting surface. With the proper mode-and-plot switch setting, the light is moved so that it illuminates from below the location on the map that is being introduced into the computer. Since ground distance between the reference point and target, as shown on the map, depends upon the map scale, the map scale

is introduced into the computer by a handcrank and counter. Corrections for constant errors in any part of the system may be introduced without disturbing the map target position  $(X_t, Y_t)$ . With  $X_j$  and  $Y_j$ , the east-west and north-south spots, added, the hitting point is changed as shown in figure 15, but the index light still shows  $X_t$   $Y_t$  as the target position. Reference point and target heights,  $H_s$  and  $H_t$ , as shown on the map, are introduced manually.

## Ship Reference-Point Quantities

These quantities are:

- B'r': Reference point bearing measured in the deck plane (from gun director).
- Br: Reference point bearing in the horizontal plane (computed).
- L' (L): Level for line of sight to reference point (computed).
- Zh (Zd): Cross level for line of sight to reference point (computed).
- jB: Computed correction to director bearing angle for error due to elevating a line of sight that is not stabilized in cross level (two-axis system).

A complete list of Computer Mk 48 Mod 1 inputs and outputs is given in pages 7 and 14. Figure 16 illustrates most of the angles involved in the Computer Mk 48 Mod 1 functioning.

## INSTRUMENT SOLUTION

In computing the location of an obscured target the instrument solution starts with polar coordinates of a reference point obtained from a director that trains in the deck plane, and rectangular map coordinates in a horizontal plane of the reference point and target. From this mixed information the target's location must be calculated in terms of simulated director measurements acceptable to the gun order computer (Range Keeper Mk 8 or Computer Mk 1A). In all, two deck-tilt corrections and two coordinate conversions are required. The director measurement of reference-point position is corrected to the horizontal plane and then converted to N-S E-W map coordinates. These are combined with other map coordinates to locate the target with respect to own ship, after which reversion to horizontal polar coordinates and correction to the deck plane produce the required gun-order-computer inputs.

The Computer Mk 48 Mod 1, therefore, must combine three sets of input data. These are:

Location of the reference point with respect to the ship. The reference point is located in terms of map height, range, and director train in the deck plane (a form of polar coordinates).

Location of the target with respect to the reference point. The target and reference point are located with respect to a common origin, and therefore to each other, in terms of horizontal rectangular coordinates and heights from the horizontal plane. The origin is the map point that lies

at the exact center of the plotting area.

Level and cross level referenced to the target line of sight.

These quantities must be manipulated to produce the outputs:

Offset relative target bearing (director train to target).

Target slant range.

Angle of elevation between line of sight to target and horizontal plane.

Director train to the reference point,  $B'r'$ , is corrected for deck tilt by functions of level and cross level. Reference point range,  $R$ , is combined with reference point height,  $H_s$ , to produce the reference point elevation angle,  $E_s$ , and horizontal range,  $R_h$ .  $R_h$  and the reference point horizontal bearing then are solved for  $R_h \sin B$  and  $R_h \cos B$  coordinates in the horizontal plane parallel, respectively, to the  $X$  and  $Y$  map axes.

These then are combined with the horizontal distance from the reference point to target,  $(X_t - X_a, Y_t - Y_a)$ , and the spot corrections,  $(X_j, Y_j)$  to compute  $OR_h \sin OB$  and  $OR_h \cos OB$ , the horizontal rectangular coordinates of the actual hitting point.

$OR \sin OB$  and  $OR \cos OB$  then are combined to produce  $OR_h$ , horizontal target range, and  $OB$ , horizontal target bearing.

$OR_h$  and target map height,  $H_t$ , are used to solve for  $E_t$ , target elevation, and  $OR$ , target slant range.  $OB$  is modified by deck-tilt corrections to form  $OB'r'$ , offset relative target bearing in the deck plane.

The quantities,  $OR$ ,  $E_t$ , and  $OB'r'$  then are transmitted to the gun order computer.

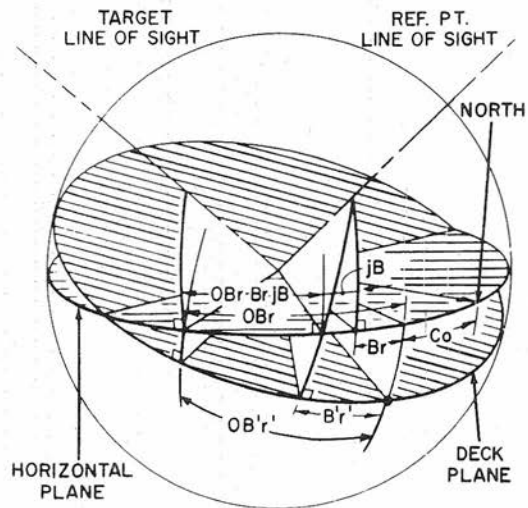

HORIZONTAL PLANE AND DECK PLANE ANGLES

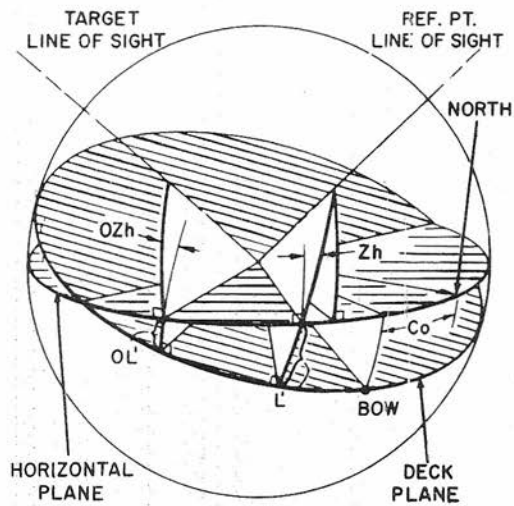

LEVEL AND CROSS-LEVEL ANGLES

Figure 16. Angles Involved in Indirect Fire Control

In the AA system, Et is used in the computations of ballistic quantities that establish the correct trajectory for a target of given elevation. In the MB system, the trajectory is based on the value of advance range alone, and the value of Et serves merely to elevate a trajectory computed for

a horizontal line of sight so that the point of impact coincides with the elevated target. Since the elevation angles involved are small, the inaccuracies introduced by assuming a rigid main battery trajectory are negligible.

#### Section 4.2—Function

Computer Mk 48 Mod 1 is divided functionally into a horizontal section and a deck-tilt section. The general functioning of these sections is illustrated in flow diagrams, figures 29 and 37.

The horizontal section computes target range, OR, and the target-elevation angle, Et, for transmission to a gun order computer, horizontal parallax, Ph, and a range-tracking aid,  $\Delta cR$  (both quantities with respect to the reference point) are computed and transmitted to a director. The computation of these quantities is based on inputs of reference range, R, and reference director train, B'r', obtained from a director; ship's course, Co, from the gyro compass; ship's speed, So, from the pitometer log; and on handcrank inputs based on information obtained from a chart mounted on the plotter. These inputs are reference height, Hs, target height, Ht, and the N-S E-W coordinates of reference point and target positions (Xa, Ya, and Xt, Yt). The functioning of the horizontal section also requires inputs of  $\sin Zh$ , (Br + jB), and (B + jB) from the deck-tilt section of the computer, as shown in figure 29. In addition, the intermediate quantities -jB and OB for use in the deck-tilt section of the computer are computed in the horizontal section.

In the deck-tilt section, figure 29, reference-point level, L', reference-point level plus a function of reference-point cross level,  $L + Zd/30$  (for AA Director

Mk 37), and a reference-point bearing-correction train control,  $Co + jB'r' - jB$ , are computed and transmitted to a director; target director train, OB'r', is computed and transmitted to a stable vertical (or stable element) and a gun order computer. The computation of these quantities is based on inputs of level and cross level with respect to the target line of sight, OL' and OZh, obtained from a stable vertical, and ship's course, Co, from the gyro compass. The functioning of the deck-tilt section also requires inputs of -jB and OB from the horizontal section of the computer, as shown in figure 37; in turn the deck-tilt section computes the intermediate quantities  $\sin Zh$ , (Br + jB), and (B + jB) for use in the horizontal section of the computer. Figure 17 shows the symbols used in the schematics of this chapter and chapter 5.

#### FUNCTIONAL DESCRIPTION OF HORIZONTAL SECTION

##### Transmitted Inputs

As shown in figure 29, reference range, R, and train, B'r', are received from the director; ship's course, Co, is obtained from the gyro compass; and ship's speed, So, is transmitted from the pitometer log. These quantities are received in the computer by synchro receivers.

The Co, R, and B'r' receivers and their servo loops are similar schematically

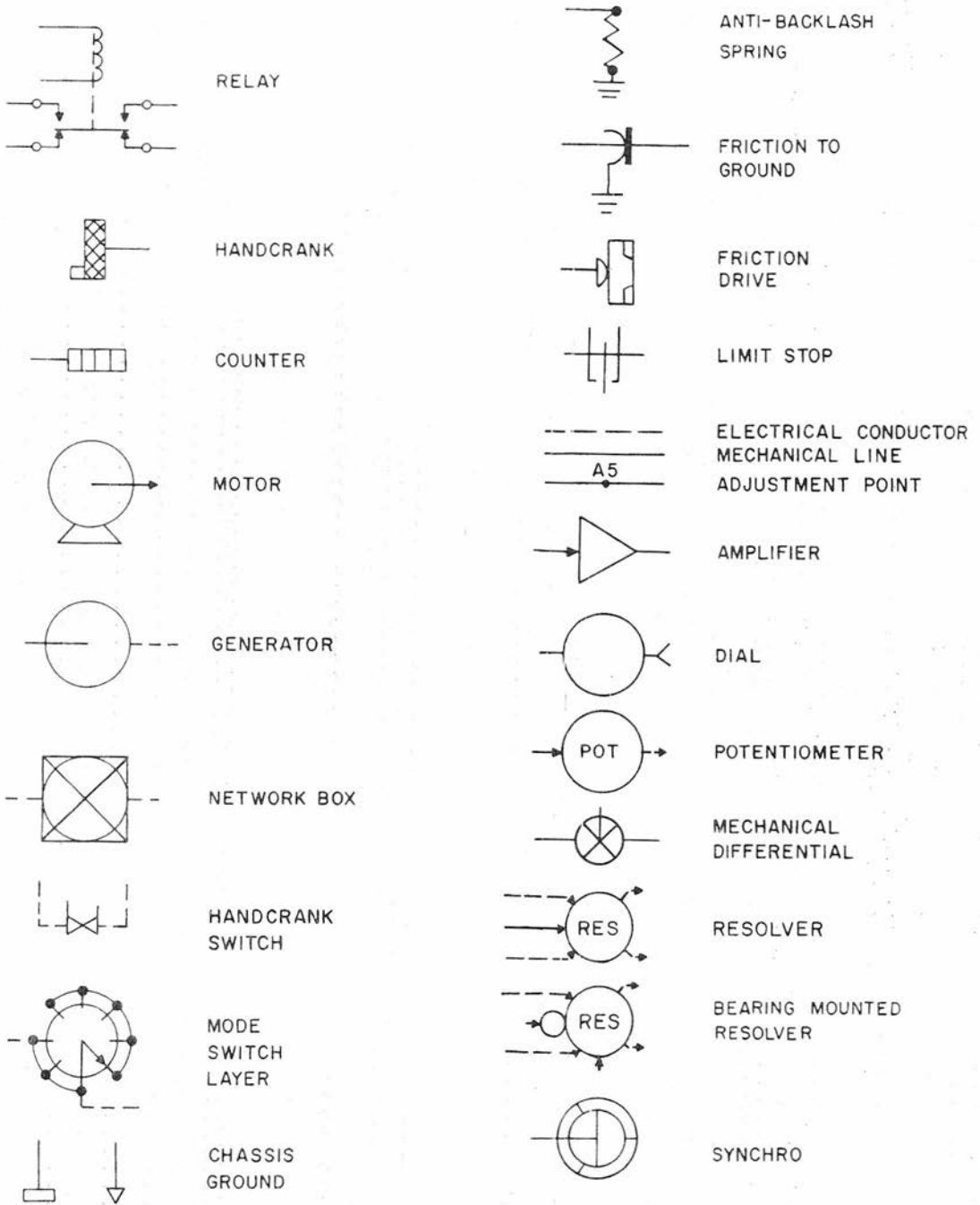

NOTE: NOMENCLATURE SYMBOLS SHOWN ON SCHEMATICS ARE FOR MB OPERATION. FOR AA OPERATION, SUBSTITUTE: Z<sub>d</sub> FOR Z<sub>h</sub>, L FOR L', OZ<sub>d</sub> FOR OZ<sub>h</sub>, OL FOR OL', B<sub>r</sub> FOR B'<sub>r</sub>, OB<sub>r</sub> FOR OB'<sub>r</sub>, AND ZERO FOR jB.

Figure 17. Schematic Symbols

and differ only in some of the elements used, figure 18. The value of each quantity is indicated on its respective coarse and fine dials. Handcranks are provided for manually setting in these quantities; when used, the handcranks actuate switches that disconnect the servo mechanisms.

The own ship's speed,  $S_o$ , receiver is a single 5B synchro that controls a 1/50 hp contact-type follow-up control and 1/50 hp servo motor, figure 19. The quantity  $S_o$  also may be cranked into the computer by hand. When the handcrank is used, a switch opens the circuit of the servo motor. The value of  $S_o$  in the computer is indicated on a counter and can vary from 0 to 55 knots. Because the  $S_o$  receiver is of the single-speed type and must cover limits greater than one revolution of the synchro (40 knots), it may have to be synchronized manually before being placed in automatic operation.

#### Computation of Elevation and Horizontal Range of Reference

The reference point elevation,  $E_s$ , and the reference-point horizontal range,  $R_h$ , computations performed in the horizontal section use the mechanisms shown in figure 20. The geometry involved is illustrated in figure 29, where  $R_h = R \cos E_s$  and  $E_s$  is the elevation angle formed between  $R$  and  $R_h$ . Reference slant range,  $R$ , is servoed into potentiometer R4002, and applies as a voltage to resolver B4080 through a network box, ZN4334, and an isolating amplifier, ZA4333B. The resolver outputs are  $R \cos E_s$ , which is  $R_h$ , and  $R \sin E_s$ , which is  $H_s$ . Reference-point elevation,  $E_s$ , is computed from the relationship  $E_s = \arcsin H_s/R$  or  $R \sin E_s = H_s$ . Reference height,  $H_s$ , is cranked into R4005, and a voltage proportional to  $H_s$  is compared in summing network ZN4307 with  $R \sin E_s$ , one of the outputs of R4080. The difference, or error, is the signal to the servo motor B4007, which drives the resolver B4080 rotor until the error is nulled. The rotor position is equivalent to  $E_s$ . The range

input to R4014 varies the gain of servo control ZB4107 in inverse proportion to range, keeping the ratio of output error to input error signal approximately constant. Amplifier ZA4333B is one half of a single unit; the other half is used as a resolver amplifier for the resolver B4092 in the deck-tilt section. G4007 is a standard 60-cycle feedback generator. An ON-OFF switch, a transformer, and a potentiometer are provided for adding a range spot to the value of  $R$  used in computing  $R \cos E_s$ , when  $R$  is being received from a radar beacon.

#### Approximation of Bearing Correction

The reference-point elevation angle,  $E_s$ , is used also in the approximation of the bearing correction,  $j_B$ , for reference point elevation and cross level when operating with an MB system. Referring to the sketch on the flow diagram, figure 29, the computation of  $j_B$  is based on the solution  $j_B = \arcsin [E_s \sin (Z_h)]$  or  $\sin j_B = E_s \sin (Z_h)$ . The true solution for  $j_B$  would be  $j_B = \arcsin [\tan E_s \tan (Z_h)]$ . In the instrument solution, sufficient accuracy is obtained by substituting  $E_s$  and the available sine function of  $Z_h$ , since the angles involved are small. As shown in figure 21,  $\sin Z_h$  and  $E_s$  are multiplied by potentiometer R4018. Resolver B4092 in the deck-tilt section supplies  $\sin Z_h$ , and  $E_s$  is servoed by B4007, figure 20. The output  $j_B$  of the servo loop, consisting of summing network ZN4304, servo control ZB4104, amplifier ZA4104, and servo motor B4004, must position the rotor of resolver B4099 at an angle equal to  $j_B$ , figure 21. This condition is obtained when the output  $-\sin j_B$  of resolver B4099 balances the servo output  $\sin (E_s \sin Z_h)$  of potentiometer R4018 in network ZN4304. The input to ZN4304 is grounded, causing the loop to zero  $j_B$  when the DIRECTOR-SELECTOR switch is thrown to AA.

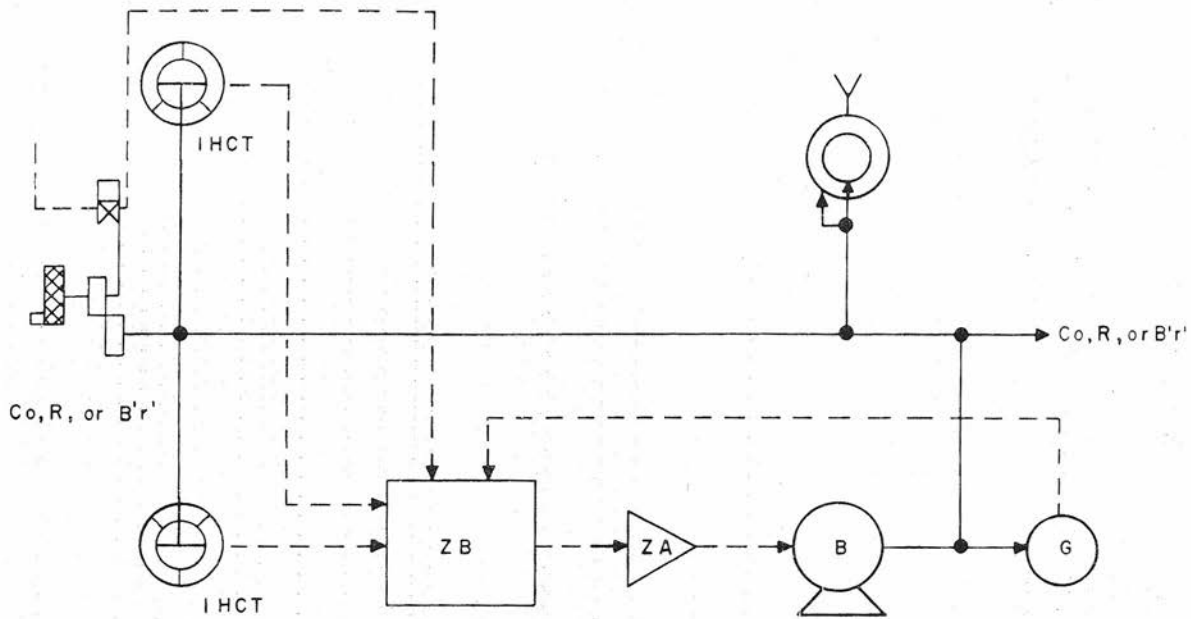

SYNCHROS		SERVO CONTROL	SERVO AMPLIFIER	SERVO MOTOR	GENERATOR	SWITCH
B'r'	B4054 10	B4055 360	ZB4106 (HIGH FIDELITY)	ZA4106	B4006 (10 WATT)	G4006 S4008
Co	B4052 10	B4053 360	ZB4105 (VELOCITY LAG)	ZA4105	B4005 (10 WATT)	G4005 S4011
R	B4050 2000 YDS	B4051 72000 YDS	ZB4102 (VELOCITY LAG)	ZA4102	B4002 (5 WATT)	G4002 S4009

Figure 18. Co, R, or B'r' Receiver

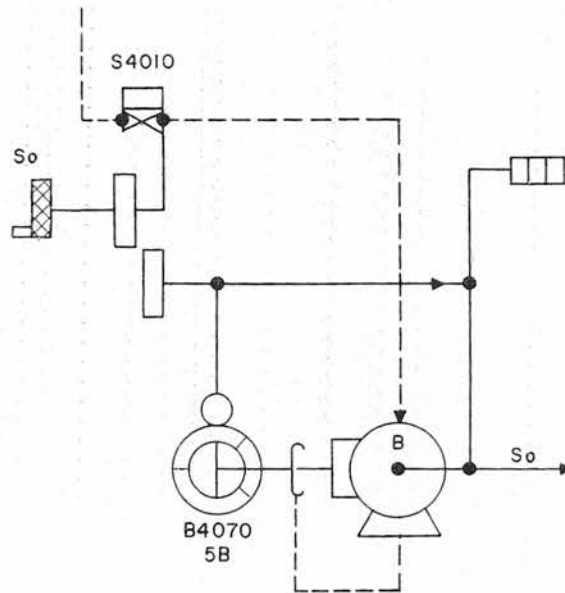

Figure 19. So Receiver and Follow-up

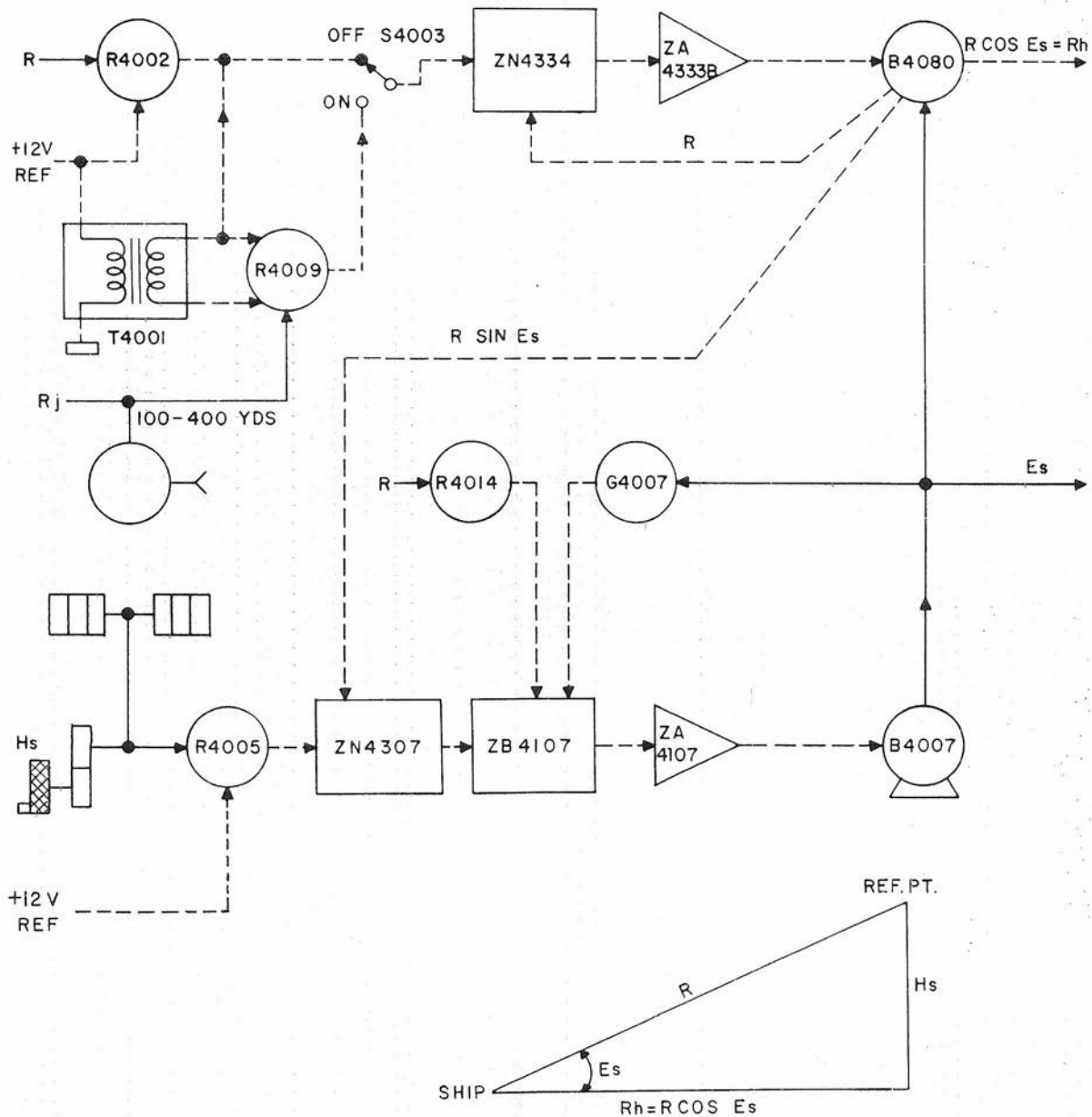

Figure 20. Computation of  $E_s$  and  $R_h$

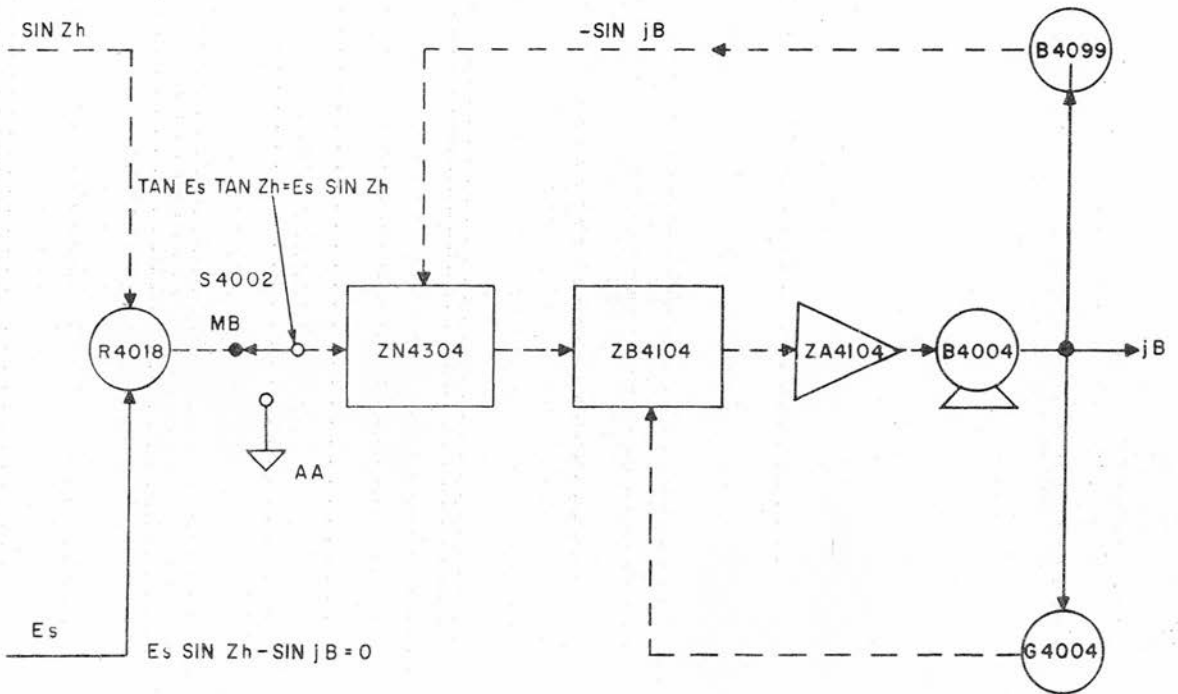

Figure 21. Computation of  $jB$

### Coordinate Conversion

The conversion of the reference-point horizontal coordinates from polar to rectangular, shown on figure 29, is accomplished in the computer by the mechanisms diagrammed in figure 22.

Resolver B4081 computes  $\pm Rh \cos B$  and  $\pm Rh \sin B$  from the inputs  $Rh$ ,  $-jB$ , and  $(B + jB)$ . The geometry involved is shown on figure 29. Resolver B4081 is bearing mounted, permitting the addition of  $-jB$  and  $(B + jB)$ .  $Rh$  is the electrical input obtained from resolver B4080, figure 20, while  $-jB$  is servoed from B4004, figure 21, the negative value being obtained by gearing, and  $(B + jB)$  is obtained from a differential, H40D1, in the deck-tilt section. Amplifier ZA4339A is one half of a dual-channel unit.

### Computation of Target Horizontal Coordinates and Conversion to Polar Coordinates.

The computation of target horizontal coordinates,  $ORh \sin OB$  and  $ORh \cos OB$ , and the vector solution of these coordinates to obtain horizontal target range,  $ORh$ , and target bearing,  $OB$ , is performed in the computer by the mechanisms shown in figure 23. The target horizontal coordinates,  $ORh \sin OB$  and  $ORh \cos OB$ , are obtained by adding voltages representing various quantities by means of network boxes. Summing network ZN4337 adds  $\pm Rh \sin B$ ,  $Xa$ ,  $-Xt$ , and  $-Xj$  and summing network ZN4338 adds the Y-axis components. All of these quantities, except  $Rh \sin B$  and  $Rh \cos B$  (see figure 29), are set into the computer by handcranks using the plotter as an indicator and the mode-and-plot switch as means of control. The sine and cosine functions are obtained from resolver B4081, as shown in figure 22.

The conversion to target bearing,  $OB$ , and horizontal target range,  $ORh$ , from  $ORh \sin OB$  and  $ORh \cos OB$ , figure 23, is based on the geometry of the associated flow-

diagram sketch from which the equations  $ORh \sin OB \cos OB - ORh \cos OB \sin OB = 0$  and  $ORh \sin OB \sin OB + ORh \cos OB \cos OB = ORh$  are derived.  $ORh \sin OB$  and  $ORh \cos OB$  are applied to the stator windings of resolver B4082 from the two amplifiers ZA4337A and ZA4337B, each of which is half of one unit. The output of one resolver rotor winding, across which the function  $ORh \sin OB \cos OB - ORh \cos OB \sin OB = 0$  appears, is servoed by a loop consisting of servo control ZB4316, servo amplifier ZA4316, servo motor B4016, and generator G4016, causing the resolver rotor to be positioned at angle  $OB$  by the servo motor. Generator G4016 provides velocity feedback voltage for servo loop stabilization. Any position of the resolver rotor, at other than the true value of  $OB$ , develops an error voltage across the rotor winding that feeds the servo loop. The output of the other rotor winding is  $ORh \sin OB \sin OB + ORh \cos OB \cos OB = ORh$ . Potentiometer R4022, driven by  $OR$ , provides compensation by varying the gain of servo control ZB4316 in accordance with changes in target range.  $OB$  is used as an input to differential H40D3 in the deck-tilt section.  $ORh$  is used in the computation of target range,  $OR$ , and target elevation,  $Et$ .

### Computation of Target Slant Range and Elevation Angle

The computation of target slant range,  $OR$ , and the target elevation angle,  $Et$ , is based on geometrical relationships, shown in the appropriate sketch on figure 29, which may be expressed by the equations

$$OR = ORh \cos Et + Ht \sin Et$$

$$\text{and } Ht \cos Et - ORh \sin Et = 0,$$

where  $ORh$  is the range to the target in the horizontal plane,  $Ht$  is the target height and  $Et$  is the target-elevation angle. These computations are performed by resolver B4095 and the associated networks shown in figure 24. Inputs of  $Ht$ ,  $ORh$ , and  $Et$  are

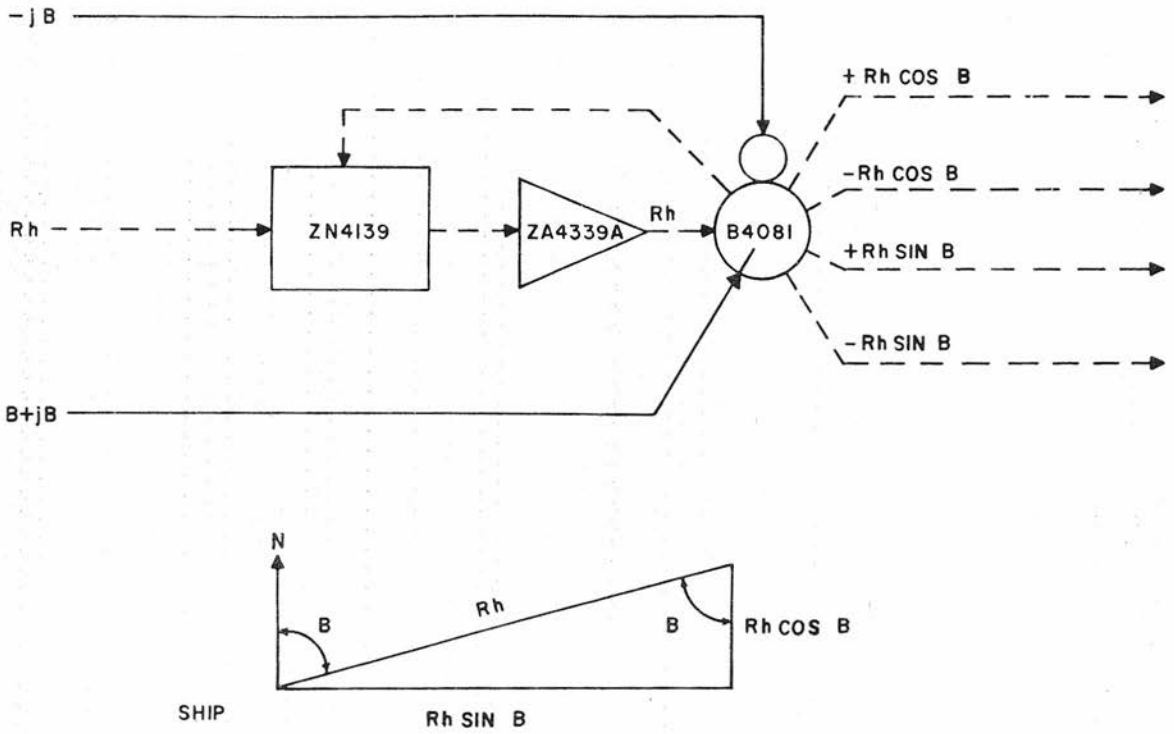

Figure 22. Conversion of Reference Point Horizontal Coordinates

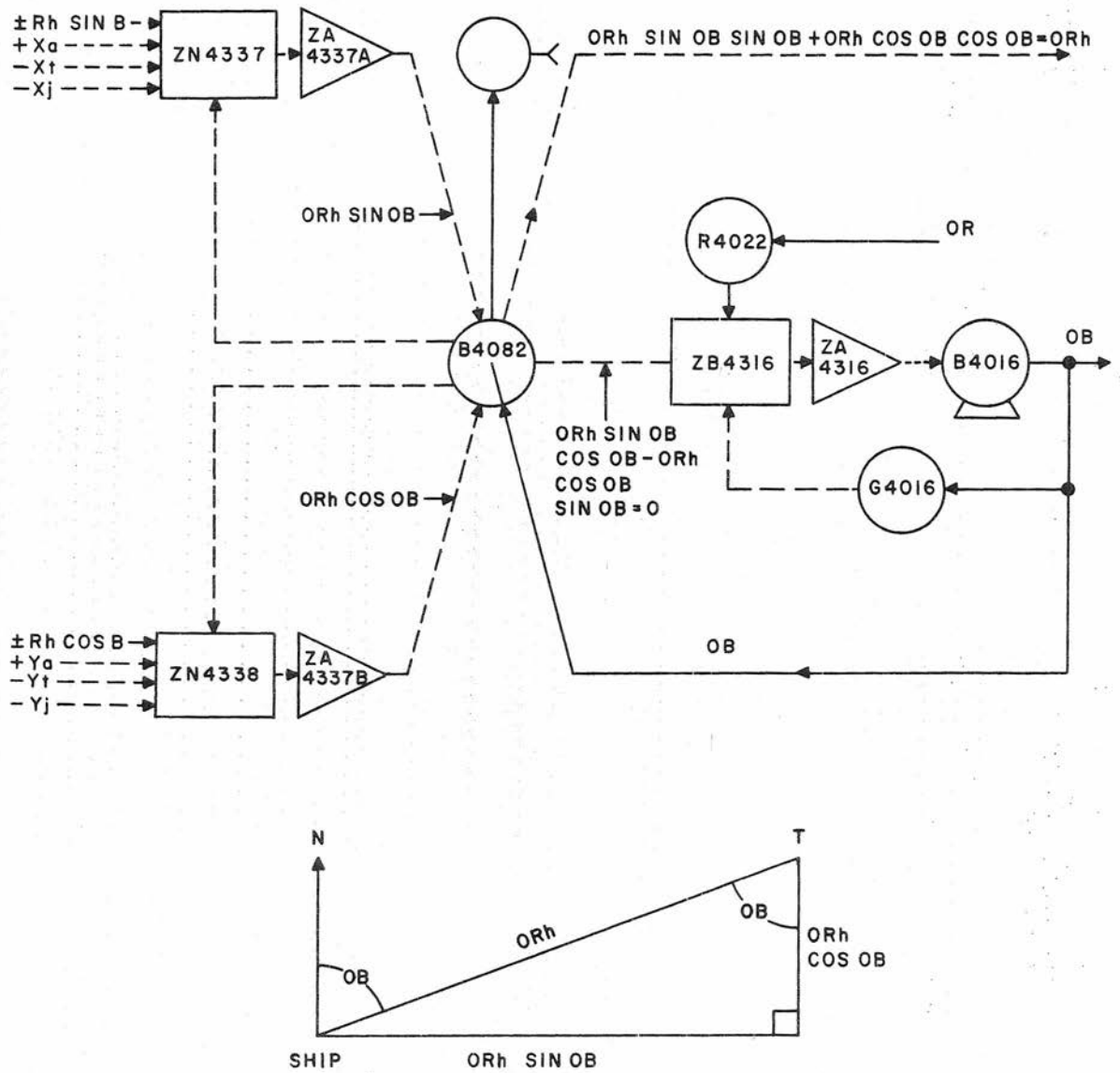

Figure 23. Conversion of Target Coordinates

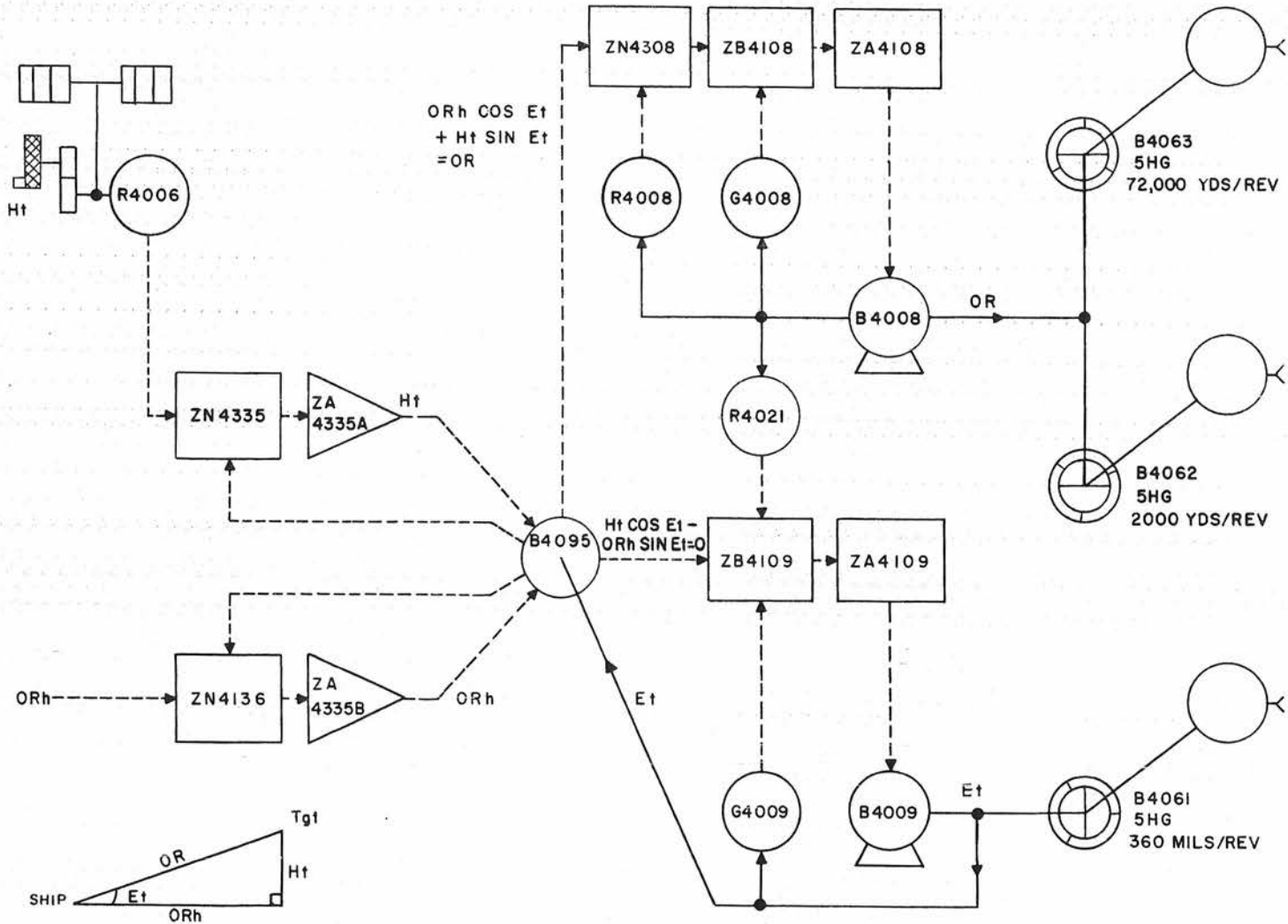

Figure 24. Computation of OR and Et

applied to resolver B4095. Ht is cranked in manually and sets potentiometer R4006 (the value of Ht cranked in is shown on one counter in feet and on another in meters). The output of the potentiometer is sent through network box ZN4335 and amplifier ZA4335A and appears across one stator winding of the resolver. ORh is applied to the other stator winding from amplifier ZA4335B and network box ZN4136. ZA4335A and ZA4335B are two halves of one dual-channel amplifier. Et sets the angular position of the resolver rotor. With these inputs, resolver B4095 computes an output on rotor winding R1-R3 of ORh  $\cos Et + Ht \sin Et$ , which is equal to OR. (See sketch on figure 29.) The correct value of Et is determined from the equation  $Ht \cos Et - ORh \sin Et = 0$ . This expression is the output of the rotor winding R2-R4 of B4095 and is used to control a servo loop. Any "error" indicates an incorrect value of Et and causes the servo loop to operate until the value of Et is correct, which occurs only when the output of R2-R4 satisfies the expression  $Ht \cos Et - ORh \sin Et = 0$ .

The output OR of resolver B4095 is applied to the OR transmitters through a servo loop consisting of summing network ZN4308, servo control ZB4108, servo amplifier ZA4108, servo motor B4008, and velocity feedback generator G4008. Potentiometer R4008 supplies the response feedback to network ZN4308. Two-speed dials are provided to indicate the value of transmitted OR. In main battery operation, OR is transmitted to Range Keeper Mk 8. In secondary battery operation, this quantity is transmitted to Computer Mk 1A. Two 5HG synchros, B4062 and B4063, at 2000 and 72,000 yards per revolution are the Computer Mk 48 Mod 1 transmitters. The transmission limits are from 500 to 50,000 yards.

The servo loop output, Et, is transmitted to Computer Mk 1A in secondary battery operation and to Target Elevation Indicator Mk 66 Mod 0, mounted on Range Keeper Mk 8, in main battery operation.

Et is inserted manually into Range Keeper Mk 8 as elevation offset. Et is inserted automatically into Computer Mk 1A. The transmitter, a 5HG synchro (B4061) at 360 mils per revolution, is equipped with a dial to indicate the transmitted value of Et. The transmission limits are 0 to 20 degrees. The Et servo loop consists of servo control ZB4109, servo amplifier ZA4109, servo motor B4009, and velocity feedback generator G4009. Potentiometer R4021, positioned by the OR servo motor, compensates the sensitivity of servo control ZB4109 for variations in range.

### Parallax Computation

The flow diagram of the horizontal section, figure 29, shows that horizontal unit parallax, Ph, is computed from inputs of reference range, R, and reference relative bearing, B'r' (director train), which is transmitted to a director. Normally, this function would be provided by Range Keeper Mk 8 or Computer Mk 1A, but when Computer Mk 48 Mod 1 is in the fire control system and the firing is at an offset target, the range and bearing inputs to the range keeper or computer, on which Ph is based, are for the offset target rather than for the reference point being tracked by the director.

Gun Director Mk 37 and Antenna Mount Mk 23 require inputs of horizontal unit parallax, Ph, for correcting train angle to a common parallax reference point on the ship. The corrected train output of each director then is equal to the train value that would be measured at the parallax reference point. Unit parallax correction is computed for a base length of 100 yards; that is, for a 100-yard displacement along the ship's axis from the parallax reference point. Each director or antenna mount determines its individual parallax correction by means of gear ratios which introduce the correction according to the proportion of its individual base length, or displacement from the parallax reference point, to the unit base length of 100 yards.

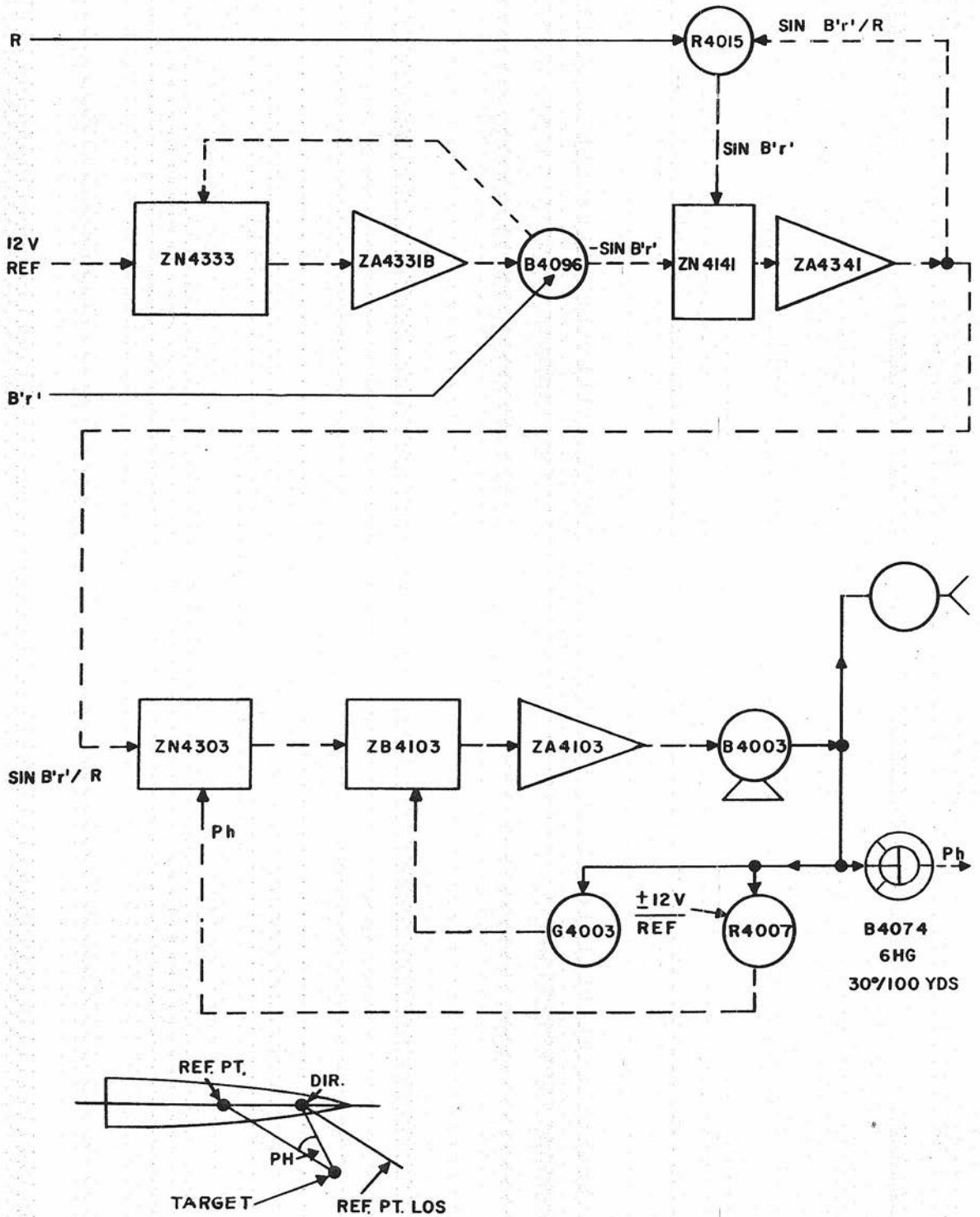

Figure 25. Computation of Ph and Ph Follow-up

Unit parallax originating in Computer Mk 1A during indirect fire cannot be used to correct director train because it is based on director train and range to the offset target. Instead, a special unit parallax correction is made up in Computer Mk 48 from values of train and range to the reference point tracked by the director.

In Computer Mk 48 Mod 1, the computation of horizontal parallax,  $Ph$ , is based on the geometry of figure 29 from which the approximation  $Ph = 5729.6 \sin B'r'/R$ , for a 100-yard base, is derived. The mechanisms used are shown in figure 25. A resolver B4096 computes  $-\sin B'r'$  from inputs of  $B'r'$  and a reference voltage applied through a network box ZN4333 and an amplifier ZA4331B. Potentiometer R4015 is driven by  $R$ .

The quantity  $-\sin B'r'$  is fed into a summing network. Disregarding network constants, the amplifier voltage output must be such that, when multiplied by  $R$  and fed back, it will tend to balance  $-\sin B'r'$ . The voltage output is, therefore,  $\sin B'r'/R$ .

Since  $Ph$  is approximately equal to  $\sin B'r'/R$  multiplied by a constant, the conventional servo mechanism, consisting of summing network ZN4303, servo control ZB4103, servo amplifier ZA4103, servo motor B4003, potentiometer R4007, and velocity feedback generator G4003, merely converts the voltage input  $\sin B'r'/R$  to ZN4303 into a mechanical shaft rotation for driving the  $Ph$  transmitter B4074. The constant in the equation is provided by the proper selection of resistances and gearing. An approximation of the true solution for  $Ph$  is entirely adequate because of the small angular value of  $Ph$  involved. The  $Ph$  transmitter transmits at a value of 30 degrees per revolution, and the value of  $Ph$  transmitted is indicated on an internal dial.

### Generation of Range and Ship's Motion

The range generation performed in the horizontal section provides a reference-range tracking aid,  $\Delta cR$  (called increments of generated range for Mk 1A and Mk 8), and the generation of changes in own ship position coordinates,  $\Delta X_o$  and  $\Delta Y_o$  provides for correcting the computations for the effects of own ship motion. While  $\Delta cR$  and the coordinate quantities  $\Delta X_o$  and  $\Delta Y_o$  are not related functionally, the instrumentation in the computer employs similar units and these quantities are developed in part from the same inputs, as shown in figure 26. Inputs of  $S_o$ ,  $C_o$ , and time,  $T$ , are used to compute  $\Delta X_o$  and  $\Delta Y_o$ , and the inputs of  $S_o$ ,  $(Br + jB)$ , and  $T$  are used to compute  $\Delta cR$ .  $\Delta cR$  is transmitted for use in the director and associated radar;  $\Delta X_o$  and  $\Delta Y_o$  are used in the plotter and in the computation of target coordinates whenever the reference point is obscured or range and bearing data are not available from the director (local control, dead reckoning, or ship-to-ship operation).

The quantity  $\Delta cR$  is the integral of  $S_o \cos (Br + jB)$  with respect to time. A mechanical resolver and a differential produce  $S_o \cos (Br + jB)$  from input of  $S_o$  and  $Br + jB$ , figure 26. The disk of the integrator H4004 is driven by time motor B4017 in all modes of operation. The quantity  $S_o \cos (Br + jB)$  from the resolver positions the carriage, and the roller output drives the transmitter B4073 at 1000 yards per revolution. The value of  $\Delta cR$  transmitted is shown on an internal dial. The time line also drives the disks of integrators H4001 and H4002 through clutch H4010, but only when the computer is in one of the dead-reckoning or local-control types of operation. The carriages of these integrators are positioned by  $dX_o$  and  $dY_o$ , obtained in the ship's rate computation from a mechanical resolver and differential H40D2 from inputs of  $S_o$  and  $C_o$ , as shown. The integrator rollers drive  $\Delta X_o$  and  $\Delta Y_o$  to differentials H40D8 and H40D7,

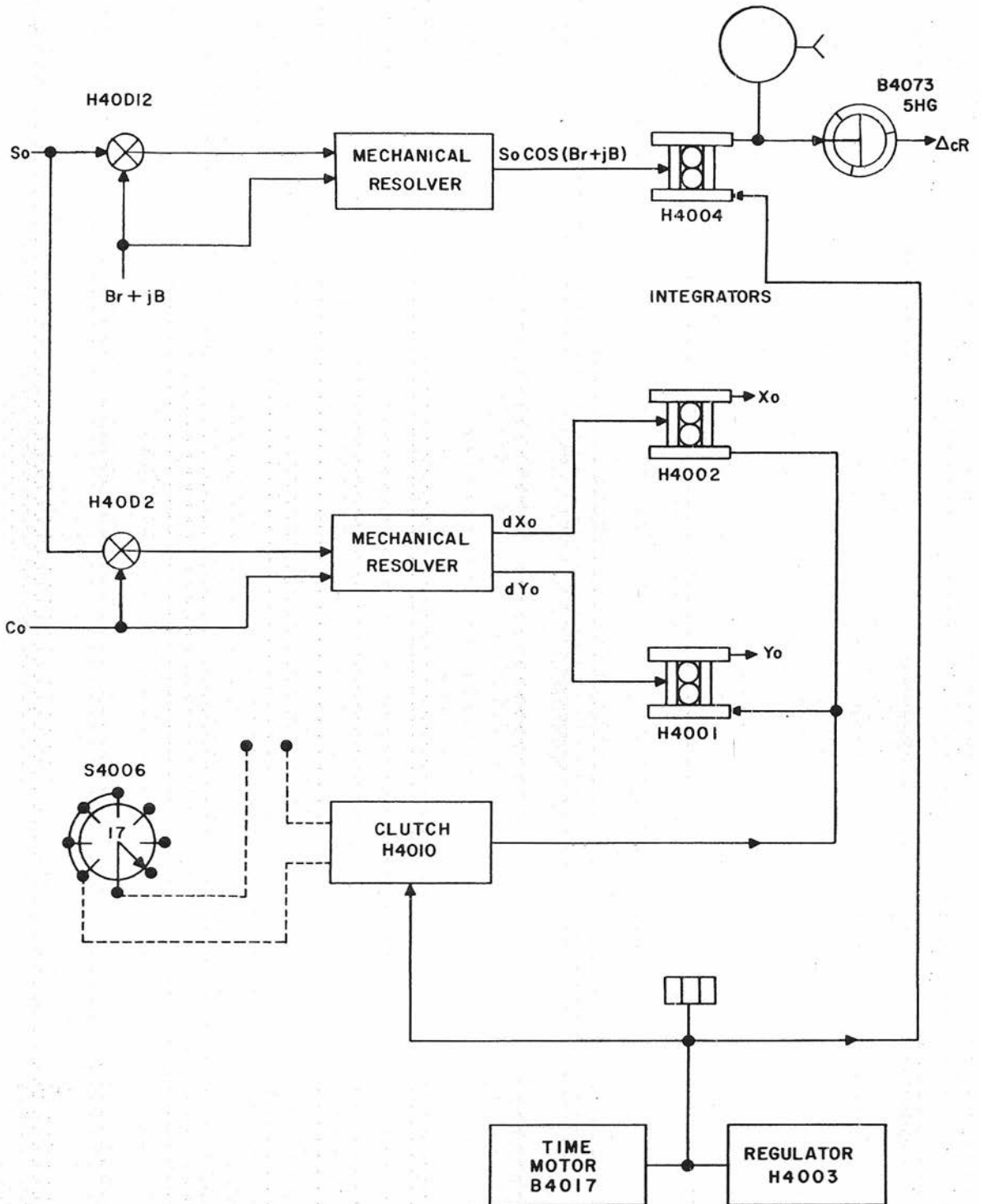

Figure 26. Computation of  $\Delta cR$ ,  $\Delta X_o$ , and  $\Delta Y_o$

figure 27; the other side of these differentials is controlled by handcranks that set the initial positions used for the plotter and for the computation of target horizontal coordinates.

### Selection of Coordinates and Plot

As figure 29 shows, the functioning of the plotter and the computing of target horizontal coordinates require inputs of X and Y quantities. These quantities, defined in chapter 2, are introduced by handcranks; they are illustrated in figures 15, 27, and 29. The values set in by the handcranks are converted to proportional voltages by means of potentiometers. The two differentials allow the substitution of  $\Delta X_o$  for Xa and  $\Delta Y_o$  for Ya as inputs, which is done when the director is not supplying range and bearing information.

The proportional voltages then are applied to the plotter and the target-horizontal coordinate-computing mechanisms through a switch (mode-and-plot switch S4006). This is a seven-position switch that serves to select the various coordinate voltages in accordance with the mode of operation and the position to be plotted. In the dead-reckoning and ship-to-ship modes, the switch reverses the polarity of the reference-point coordinates and the reference voltage going to the OB servo loop to compensate for differences in the geometry of this type of problem. In addition, this switch closes the clutch in the time line for all modes other than shore bombardment, figure 26. The seven positions of the switch are listed in table 11.

The three shore-bombardment positions of the switch, when used in sequence, establish in the plotter and the computer the relative positions of own ship, reference, and target, provided the necessary data are fed in by means of the various handcranks and synchros. For example, in the shore-bombardment mode of operation, which is the main function of the computer,

the switch is first set at SHORE BOMB SHIP. In this position the inputs to the plotter are  $X_a - R_h \sin B$  and  $Y_a - R_h \cos B$ . As can be seen from the sketch on the flow diagram, these are the north-south and east-west distances of own ship from the origin. In terms of X-axis coordinates, the next two positions (SHORE BOMB REF and SHORE BOMB TGT) establish the location of reference point and target with respect to the origin by successively connecting Xa and Xt to the plotter network box ZN4301, figure 28.

The proper values for Xa and Xt are determined by moving the Xa and Xt handcranks to position the plotter index light at the locations of reference point and target on the chart, thus setting up the proper voltage relationships for these quantities in both the plotter-servo mechanisms and the target-horizontal coordinate-computing mechanism.

Since the computer must compute the location of the target continuously, the switch sections controlling the computer are arranged to maintain identical inputs for all the plot positions in a given mode. A summation of the inputs to the plotter and the computer for the various switch positions is shown in table 11. For simplicity, only X-axis coordinates are listed; for Y-axis coordinates, substitute Y for X and cosine for sine. In the secondary modes of operation (local control and dead reckoning) the inputs available, as shown in table 11, are designed for operation without director aids and for navigational purposes.

The mechanisms used in the plotter are diagrammed in figure 28. Because the plotter is designed for use with charts and maps of varying scales, a scale-factor control in the form of a precision potentiometer, R4001, positioned by the scale-factor handcrank and counter, is used to vary the scale of the plotting. The output of this potentiometer, proportional to the scale factor, is supplied through summing network ZN4342 and amplifier ZA4342 to response potentiometers R100 and R101

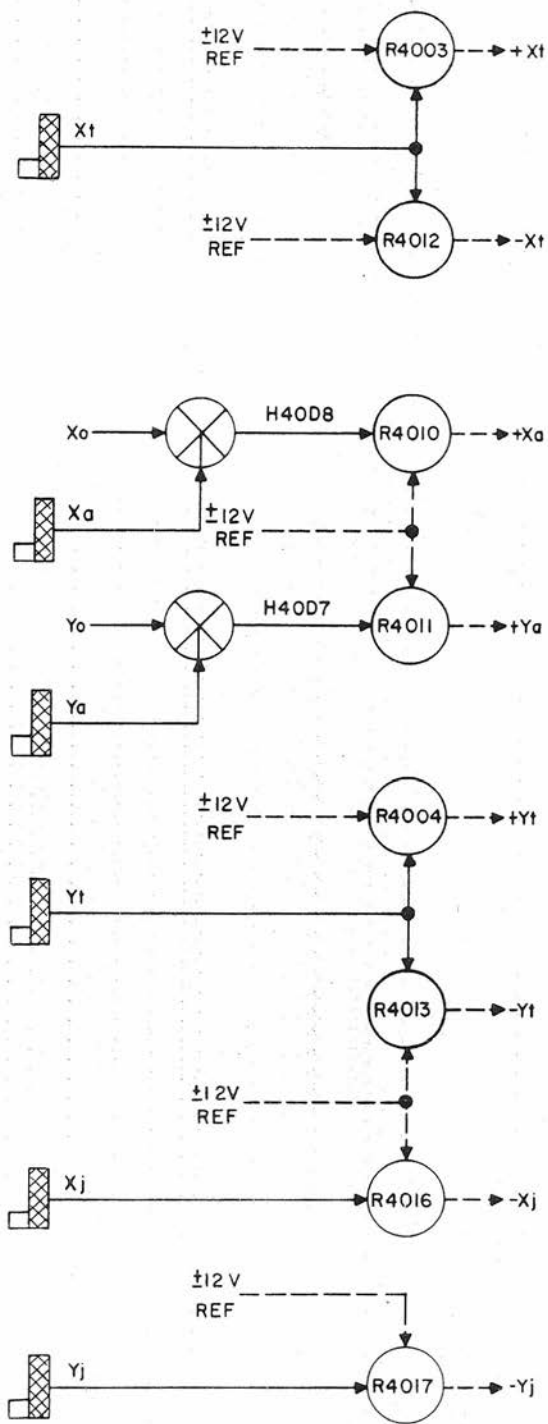

Figure 27. Target, Reference, and Spot Coordinate Inputs to Computer Mk 48 Mod 1

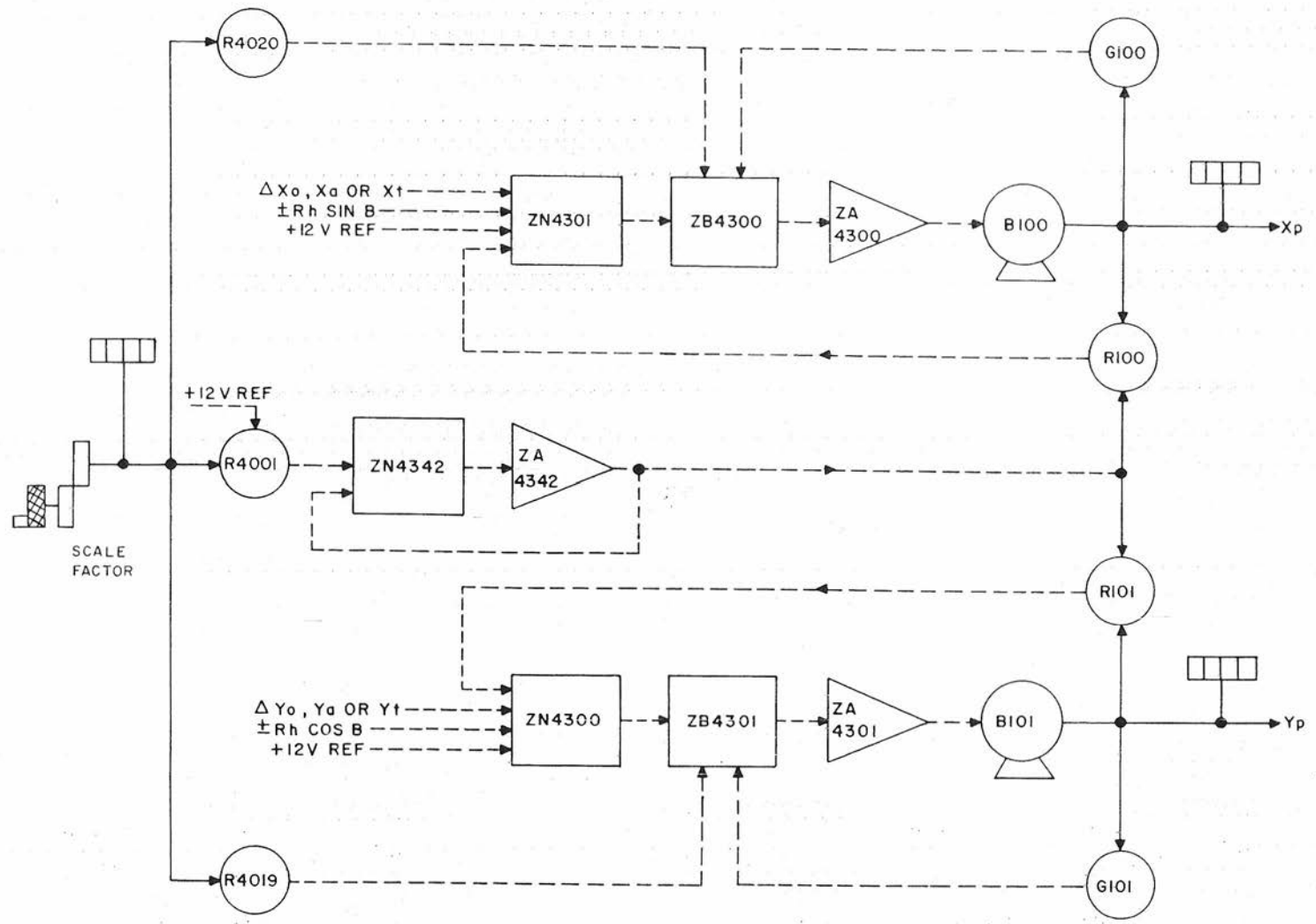

Figure 28. Scale Factor and Coordinate Inputs to Plotter

DECLASSIFIED  
 Authority: 34869  
 by: JM NADA Date: 11

Table 11  
 MODE-AND-PLOT SWITCH FUNCTION

Switch Position	Input to Plotter	Input to Computer
SHORE BOMB SHIP	$X_a - R_h \sin B$	$X_a - R_h \sin B - X_t$
SHORE BOMB REF-PT	$X_a$	$X_a - R_h \sin B - X_t$
SHORE BOMB TGT	$X_t$	$X_a - R_h \sin B - X_t$
LOCAL CONTROL SHIP	$X_a + \Delta X_o$	$X_a + \Delta X_o - X_t$
LOCAL CONTROL TGT	$X_t + \Delta X_o$	$X_a + \Delta X_o - X_t$
DEAD REK'NG SHIP	$X_a + \Delta X_o$	$+ R_h \sin B$
DEAD REK'NG TGT	$X_a + \Delta X_o + R_h \sin B$	$+ R_h \sin B$

in the  $X_p$  and  $Y_p$  servo loops. The sliding contacts of R100 and R101, positioned by the  $X_p$  and  $Y_p$  servos, therefore deliver to the respective summing networks response voltages which are proportional to the scale factor as well as to  $X_p$  and  $Y_p$ . The result is a variation in mechanical response proportional to scale factor. In order to maintain the servo control sensitivity (stiffness) approximately constant for all scale factors, two additional potentiometers, R4019 and R4020, positioned by the scale-factor hand-crank, adjust the gain of the servo controls by varying the feedback voltage in accordance with the scale-factor setting. The output of the  $X_p$  and  $Y_p$  servo loops drive the respective lead screws that position the index light in the plotter. Internal counters that show in inches the value of X and Y servoed into the plotter are provided.

FUNCTIONAL DESCRIPTION OF DECK-TILT SECTION

Inputs

As shown in figure 29, the stable vertical is aligned on the target by a computed

value of target bearing derived in Computer Mk 48 Mod 1. The outputs of the stable vertical, which therefore are target level and cross level, OL' and OZh, are transmitted to the OL' receiver synchros B4056 and B4057 and to the OZh receiver synchros B4058 or B4059 and B4060, which are shown in figure 30. The elements used in the standard loops for servoing the received values of OL' and OZh also are shown in figure 30. The other synchro inputs to the deck-tilt section, Co and B'r', are covered in the description of the horizontal section.

The received values of OL' and OZh are introduced mechanically into resolvers B4083, B4084, and B4085 for resolution into various sine and cosine functions as shown on figure 31. The outputs of this group, as shown on figure 37, then are applied in the two principal computations of the deck-tilt section: The computation of deck-tilt corrections for bearing angles used in the computer and the computation of reference line-of-sight deck-tilt angles for use in the director.

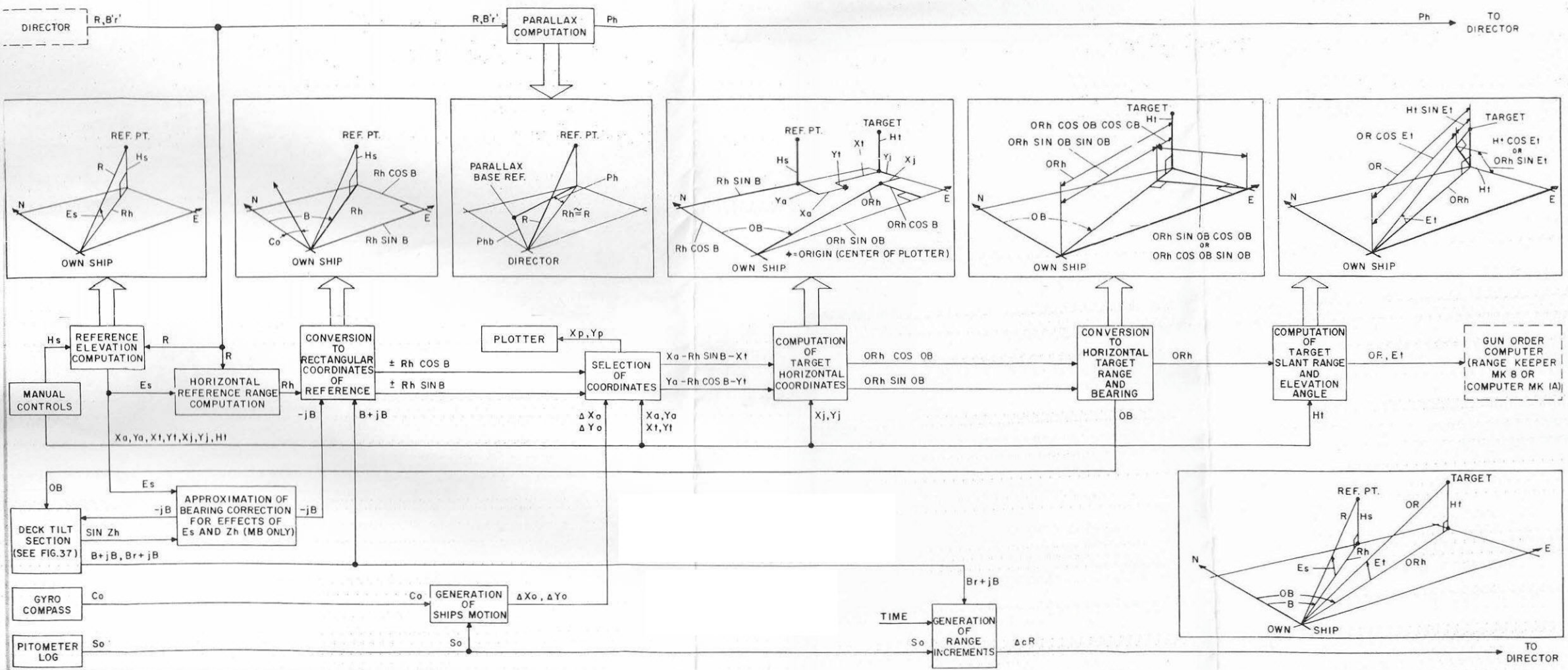

Figure 29. Flow Diagram of Horizontal Section

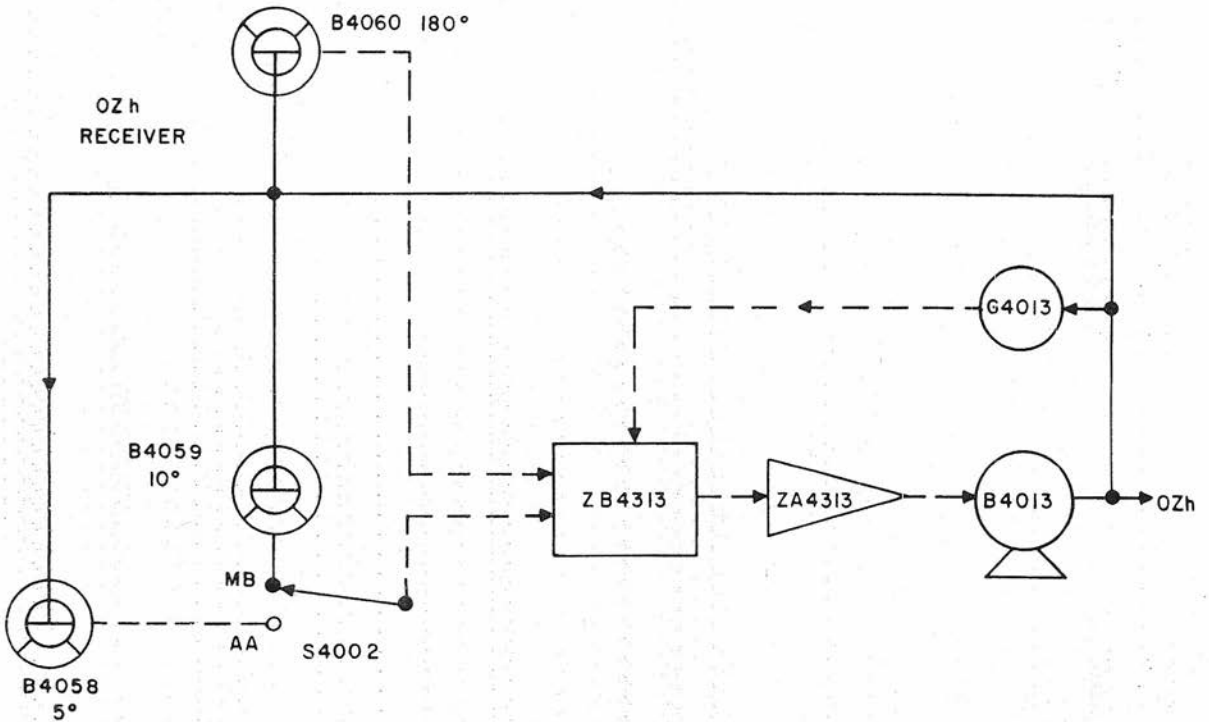
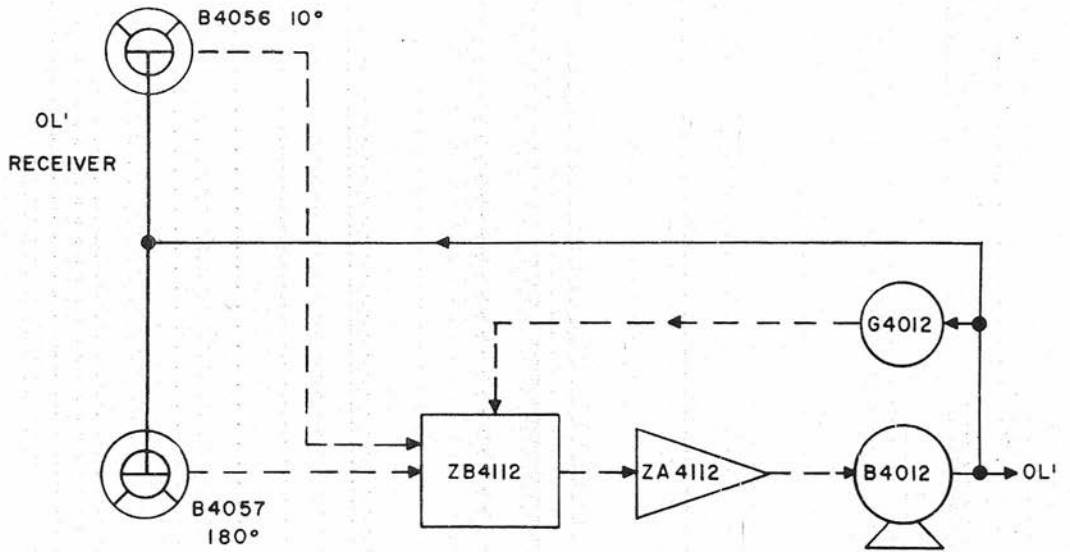

Figure 30. OL' and OZh Receivers

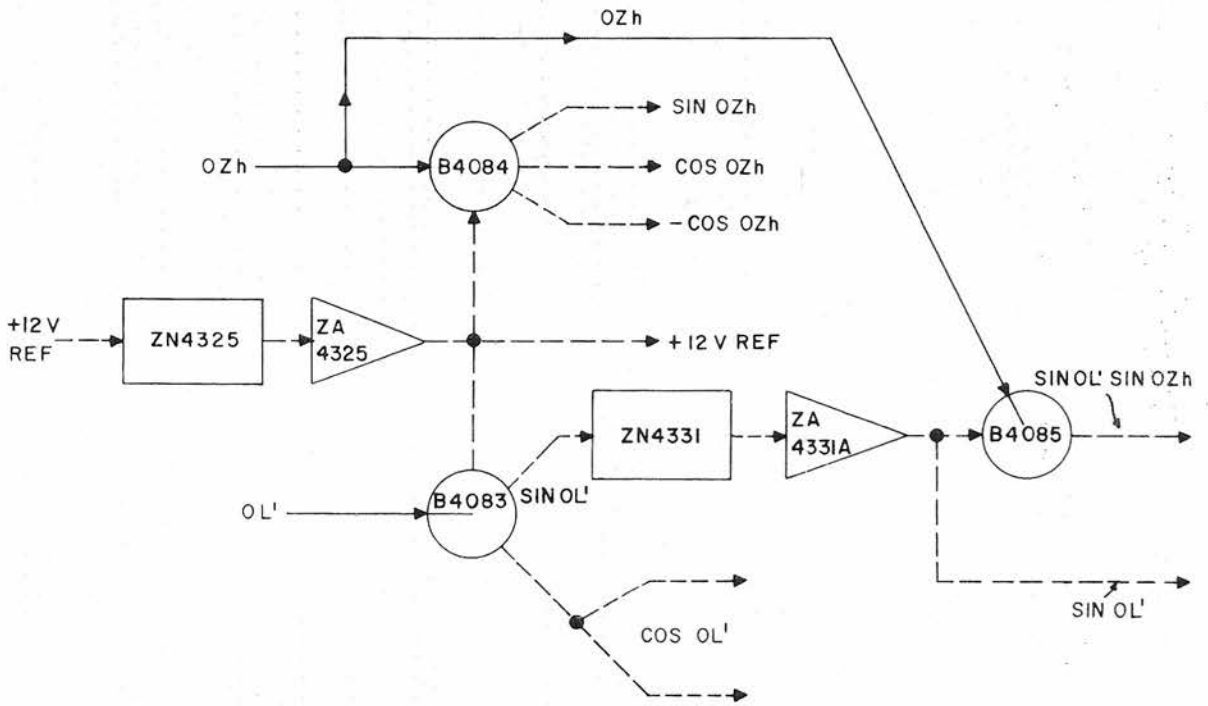

Figure 31. Resolution of Target LOS Deck-Tilt Angles

### Computation of Target-Bearing Deck-Tilt Correction

The sine and cosine functions of  $OL'$  and  $OZh$ , derived as shown in figure 31, first are applied in the computation of multiple functions required as intermediate quantities for computing the deck-tilt corrections. The components used in combining these functions are shown in figure 32. The resulting multiple functions then are used in the computation of the target-bearing deck-tilt correction  $jOB'r'$

The quantity  $jOB'r'$  is defined as equal to  $OBr - OB'r'$ , target bearing in the horizontal plane minus target bearing in the deck plane, as shown in figure 37. The solution is based on the equation

$$\begin{aligned} & -\sin jOB'r' (\cos OL' + \cos OZh) \\ & \textcircled{+} \cos jOB'r' (\sin OL' \sin OZh) \\ & -\cos (2 OB'r' + jOB'r') (\sin OL' \sin OZh) \\ & -\sin (2 OB'r' + jOB'r') (\cos OL' - \cos OZh) \\ & = 0. \end{aligned}$$

The same instrumentation is used to compute the corresponding three-axis correction,  $jOB'r$ . As may be seen by comparing the equations for each, only the circled signs differ.

$$\begin{aligned} & -\sin jOB'r (\cos OL + \cos OZd) \\ & \textcircled{+} \cos jOB'r (\sin OL \sin OZd) \\ & -\cos (2 OB'r + jOB'r) (\sin OL \sin OZd) \\ & -\sin (2 OB'r + jOB'r) (\cos OL - \cos OZd) \\ & = 0 \end{aligned}$$

When Computer Mk 48 is switched from MB to AA operation, the corresponding AA quantities are introduced and the polarity of a unit transmitting  $-\cos jOB'r' (\sin OL' \sin OZh)$  (MB) is reversed.

As shown in figure 32, the four terms of this equation are computed in four resolvers, B4086 through 4089, from electrical inputs of multiple-level and cross-level functions and mechanical inputs of  $jOB'r'$  and  $2 OB'r'$ . The four resolver outputs are combined in network ZN4315 to set up the equation. Any output value other than zero (null) results in appropriate rotation of the  $jOB'r'$  servo, which adjusts the value of  $jOB'r'$  and  $2 OB'r'$  until the equation is balanced.

The quantity  $2 OB'r'$  is obtained from differential H40D5, figure 35, through a 2-to-1 gear ratio. This value is introduced mechanically to the stators of bearing-mounted resolvers B4086 and B4087 so that the rotor-stator relationship is  $2 OB'r' + jOB'r'$ .

The sine and cosine quantities are obtained from the resolvers shown in figure 31. Amplifiers ZA4329A and ZA4329B, figure 32, are two halves of a dual-channel unit. The servoed output  $jOB'r'$  also is used to drive differentials H40D6, figure 35, and H40D9, figure 34.

### Computation of Combined Deck-Tilt Corrections

The computation of the combined bearing-correction angles for deck tilt,  $jOB'r' - jB'r'$ , also makes use of the multiple sine and cosine functions of  $OL'$  and  $OZh$ . This computation is based on the relationship  $jOB'r' - jB'r' = (OBr - Br) - (OB'r' - B'r')$ , illustrated in figure 16. The equation used in the computer is derived from this diagram, and is:

$$\begin{aligned} & \textcircled{+} \left\{ \sin [2(OBr - Br - jB) - (jOB'r' - jB'r')] \right\} \\ & (\cos OL' - \cos OZh) \\ & \textcircled{+} \left\{ \cos [2(OBr - Br - jB) - (jOB'r' - jB'r')] \right\} \\ & (\sin OL' \sin OZh) \end{aligned}$$

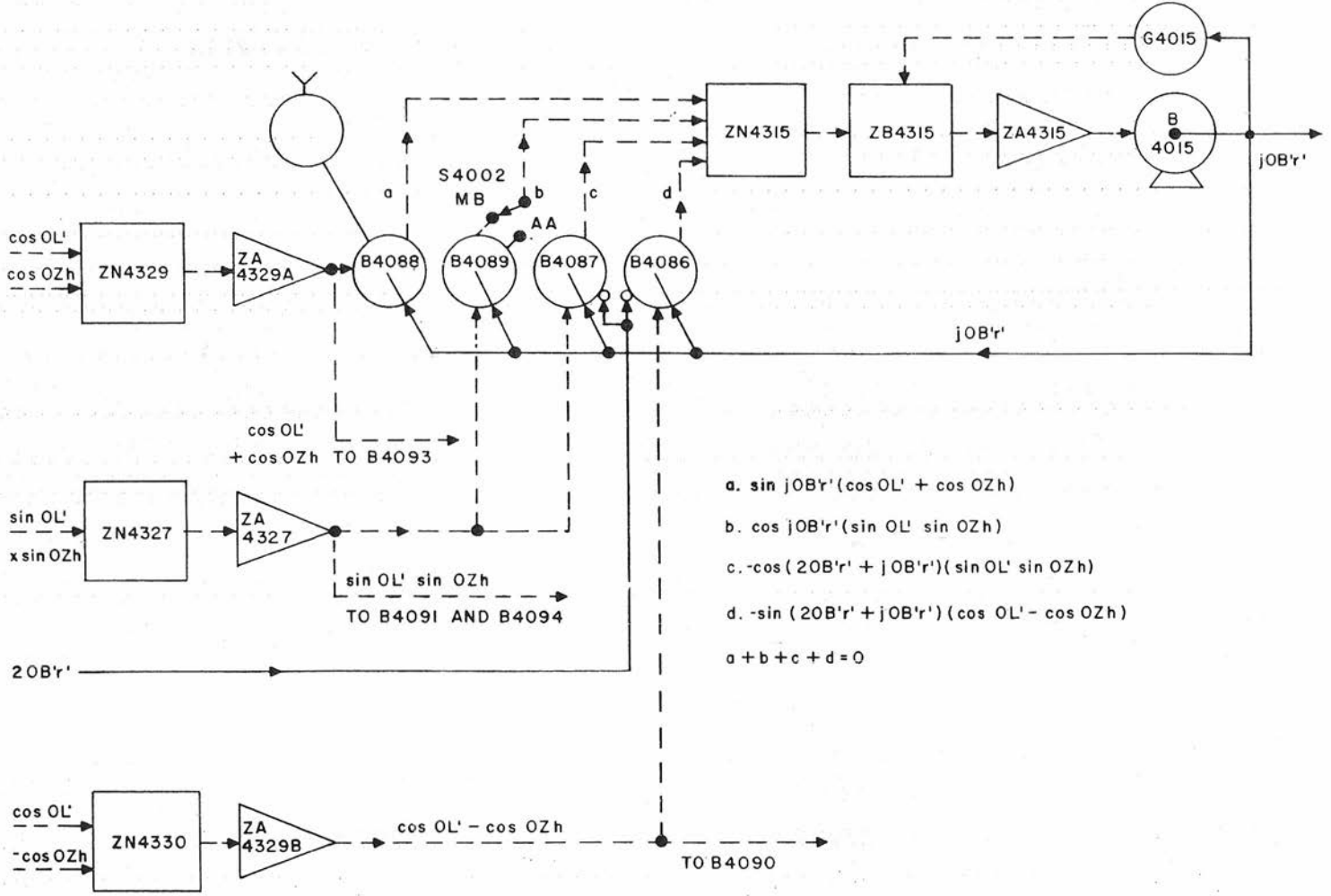

Figure 32. Computation of jOB'r'

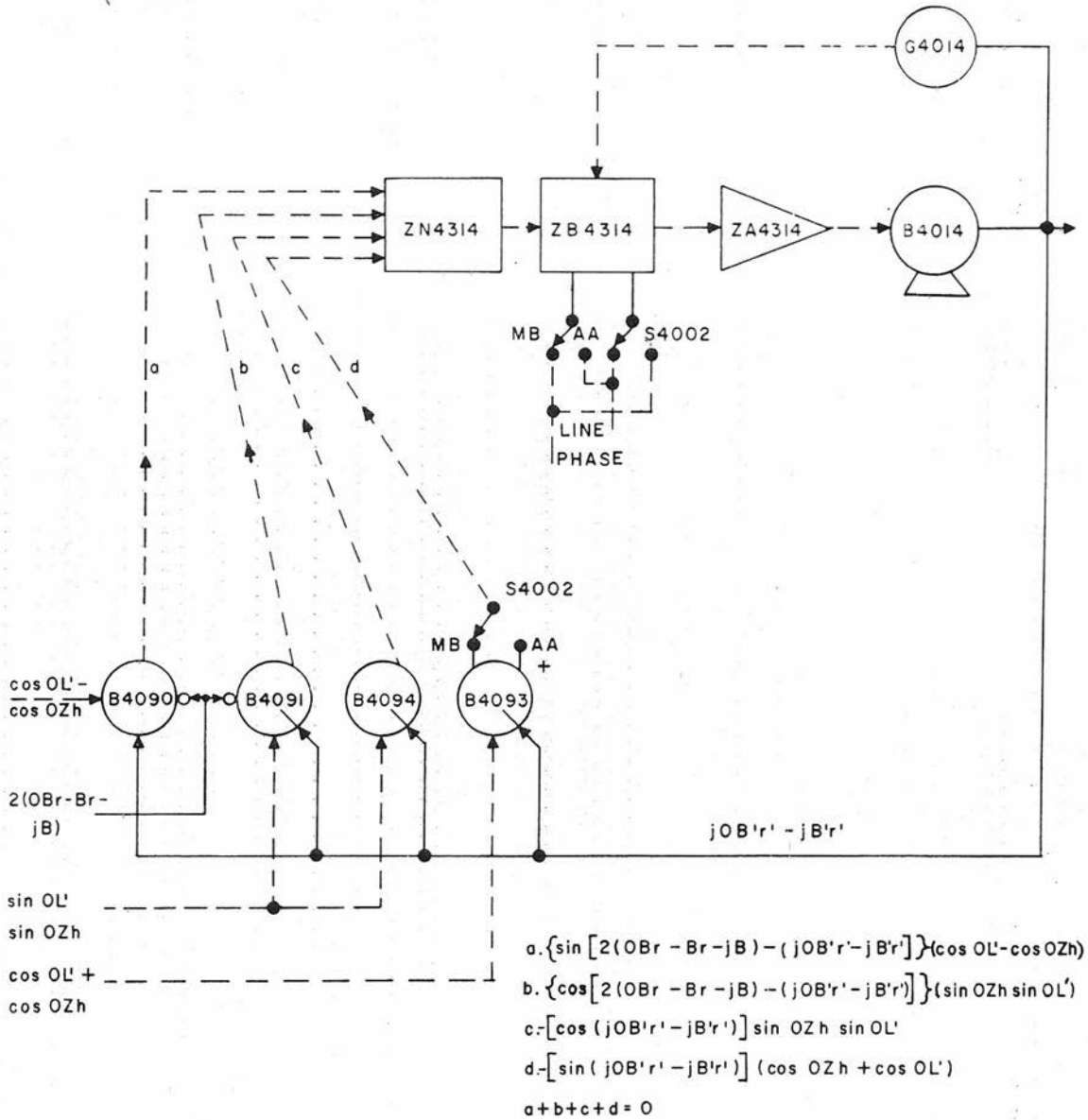

Figure 33. Computation of  $jOB'r' - jB'r'$

$$\begin{aligned} & \ominus [\cos (jOB'r' - jB'r')] (\sin OZh \sin OL') \\ & - [\sin (jOB'r' - jB'r')] (\cos OZh + \cos OL') \\ & = 0. \end{aligned}$$

The instrument solution of the equation, shown in figure 33, is similar to that described in the previous paragraph for  $jOB'r'$ . Each of the four resolvers, B4090, B4091, B4093, and B4094, produces a term of the equation from electrical inputs of the multiple functions of level and cross level and mechanical inputs of  $jOB'r' - jB'r'$  and  $2(OBr - Br - jB)$ . Network ZN4314 sums the four resolver outputs, which should total zero. If the mechanical inputs do not correspond with the electrical inputs to the resolvers, the output of the summing network will be other than zero, causing the servo motor to change the mechanical inputs until the equation is balanced.

The same instrumentation is used to compute the corresponding three-axis correction,  $jOB'r - jB'r$ .

$$\begin{aligned} & \ominus \left\{ \sin [2(OBr - Br) - (jOB'r - B'r)] \right\} \\ & (\cos OL - \cos OZd) \\ & \ominus \left\{ \cos [2(OBr - Br) - (jOB'r - B'r)] \right\} \\ & (\sin OL \sin OZd) \\ & \oplus [\cos (jOB'r - jB'r)] (\sin OL \sin OZd) \\ & - [\sin (jOB'r - jB'r)] (\cos OL + \cos OZd) \\ & = 0. \end{aligned}$$

The AA equation differs from the MB equation only by omitting  $-jB$  and by the circled signs. When Computer Mk 48 Mod 1 is switched from MB to AA operation,  $-jB$  is no longer contributed to the solution and the sign changes indicated are accomplished by changing the polarity of the proper components through the contacts of the MB-AA switch, S4002.

Servo motor B4014 also drives one end gear of differentials H40D9 and H40D4, figures 34 and 35, which take part in the summing of mechanical bearing quantities, as described in the following paragraphs. One of these bearing quantities,  $OBr - Br - jB$ , obtained from differential H40D3, is doubled in the gearing and positions the stators of bearing-mounted resolvers B4090 and B4091; the rotor-stator relationship is therefore  $2(OBr - Br - jB) - (jOB'r' - jB'r')$ . The sine and cosine functions for the electrical inputs are obtained from the amplifiers shown in figure 32, as previously described.

#### Summation of Reference-Bearing Corrections

The summation of reference-bearing corrections, shown on figure 37, now can be made from the shaft values of  $jOB'r'$ ,  $(jOB'r' - jB'r')$ ,  $Co$ , and  $-jB$  that are added or subtracted in the differential group, shown in figure 34, to produce  $Co + jB'r' - jB$ . These servoed quantities were derived as shown in figures 18, 21, 32, and 33. The  $Co + jB'r' - jB$  transmitter consists of a 6HG synchro at 5 degrees, B4071, and a 5HG synchro at 10 degrees, B4072. This quantity is transmitted to the directors as a correction to bearing in order to keep the director automatically on the reference point regardless of changes in deck tilt and ship course.

#### Summation of Target-Relative-Bearing Terms

In the target-relative-bearing computation,  $OB'r'$  is derived and transmitted to the stable vertical and a gun order computer. In main-battery operation the stable vertical and gun order computer are Stable Vertical Mk 41 and Range Keeper Mk 8. When the secondary battery is used,  $OB'r'$  becomes  $OB'r$  and is transmitted to Stable Element Mk 6 and Computer Mk 1A. The

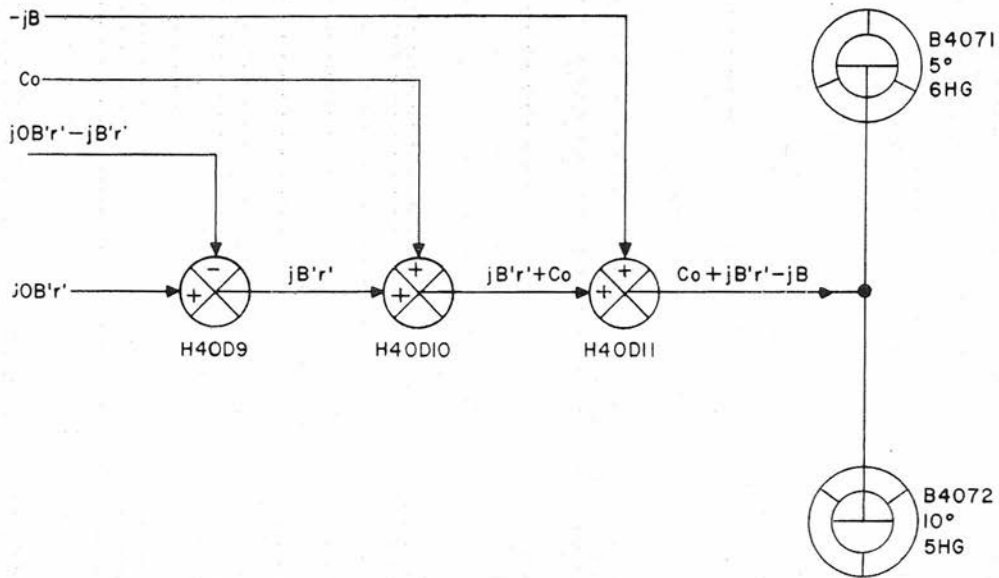

Figure 34. Summation of Reference Bearing Corrections

transmitter in either case consists of two 6HG synchros (B4068 and B4069) at 10 degrees and 360 degrees per revolution equipped with dials to indicate the computed value of  $OB'r'$ .

In terms of main-battery operation, the quantity that drives the relative-target-bearing transmitters is the sum of the two inputs,  $(OBr - Br - jB)$  and  $B'r' - (jOB'r' - jB'r')$ , of differential H40D5. This sum is equal to  $OB'r'$ , from the sketch on figure 37, where  $jOB'r' - jB'r' = (OBr - Br - jB) - (OB'r' - B'r')$ . A group of mechanical differentials, H40D4, H40D6, H40D1, and H40D3, arranged as shown in figure 35, add or subtract various intermediate quantities to provide the inputs to the two end gears of H40D5. The functions performed by the differentials are:

$$(B'r') - (jOB'r' - jB'r') \text{ (H40D4)}$$

$$B'r' - (jOB'r' - jB'r') + jOB'r' =$$

$$B'r' + jB'r' \text{ (H40D6)}$$

$$\text{Since: } B'r' = Br + jB - jB'r'$$

$$B'r' + jB'r' = (Br + jB)$$

$$(Br + jB) + Co = (B + jB) \text{ (H40D1)}$$

$$OB - (B + jB) = (OBr - Br - jB) \text{ (H40D3)}$$

Some of these quantities are used for computations elsewhere in the computer. For instance,  $(OBr - Br - jB)$  is used in the computation of  $\sin L'$  and  $\sin Zd$ , figure 36, and in the computations performed by resolvers B4090 and B4091, figure 33.  $OB'r'$  is used also in the computations of resolvers B4086 and B4087, figure 32.  $Br + jB$  is used to compute  $\Delta cR$ , figure 26, and  $B + jB$  is used to compute  $Rh \sin B$  and  $Rh \cos B$ , figure 22 in the horizontal sections.

## DIRECTOR SELECTOR Switch

As mentioned in the beginning of this chapter, provision is made in Computer Mk 48 Mod 1 to compute for both AA and MB fire control systems by means of the DIRECTOR SELECTOR switch, S4002. The functioning of this switch is outlined in the following discussion. As previously described, the train control transmitter, B4071 and B4072, transmits the quantity  $Co + jB'r' - jB$ , figure 34. When the computer is operating with an MB fire control system,  $jB$  can be any value between plus and minus 15 degrees; when an AA system is in use,  $jB$  is always zero. The geometry of these relationships is shown in figure 37. In the computer, the solution for  $jB$ , figure 21, is based on the approximation  $\tan Es \sin Zh = \sin jB$ . DIRECTOR SELECTOR switch, S4002, functions in the solution as follows: In the MB position, switch S4002 connects a voltage proportional to  $\tan Es \sin Zh$  to the network, follow-up, and resolver used to compute  $jB$ . The follow-up positions the resolver rotor so that the sine output of the resolver ( $-\sin jB$ ), when added to  $\tan Es \sin Zh$ , equals zero; this occurs when the resolver rotor is at angle  $jB$ ; hence the response of the follow-up is a shaft rotation equal to  $jB$ . In the AA position, the switch connects the input of the network to ground; the  $jB$  servo then nulls the loop by changing  $jB$  until the output of the resolver sine winding (response) equals zero or ground potential, at which point  $jB$  is equal to zero.

The DIRECTOR SELECTOR switch is used also to switch the fine receivers used with the coarse 180-degree (2-speed) target line-of-sight cross-level receiver B4060, as shown in figure 30. This switching is done to match the receiving synchros with the transmitting synchros in the stable vertical or stable element. Thus, in the MB position the receivers correspond with the 180- and 10-degree (2- and 36-speed) synchros in Stable Vertical Mk 41, which is used in the MB fire control system; in the AA position, the receivers correspond with

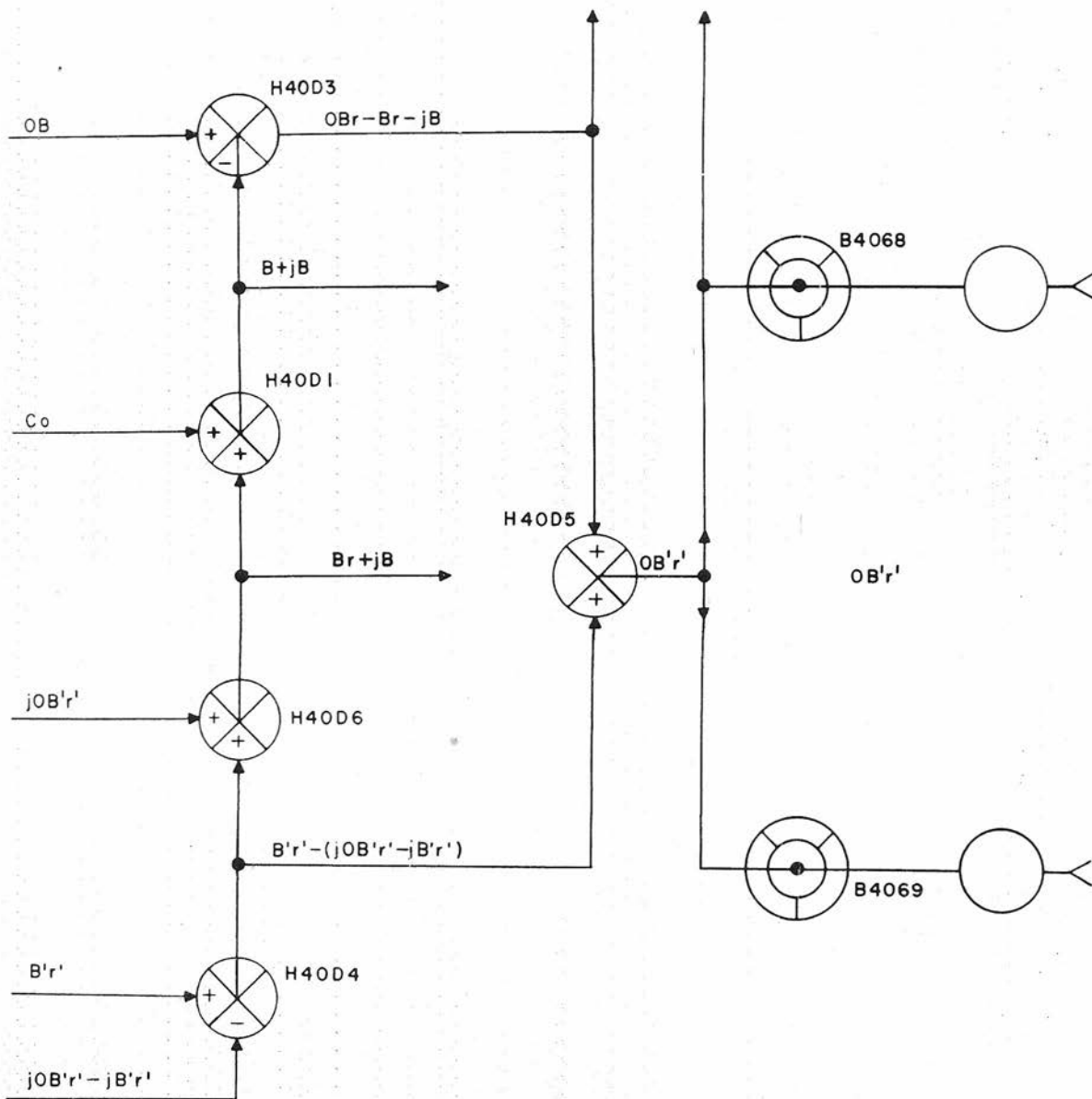
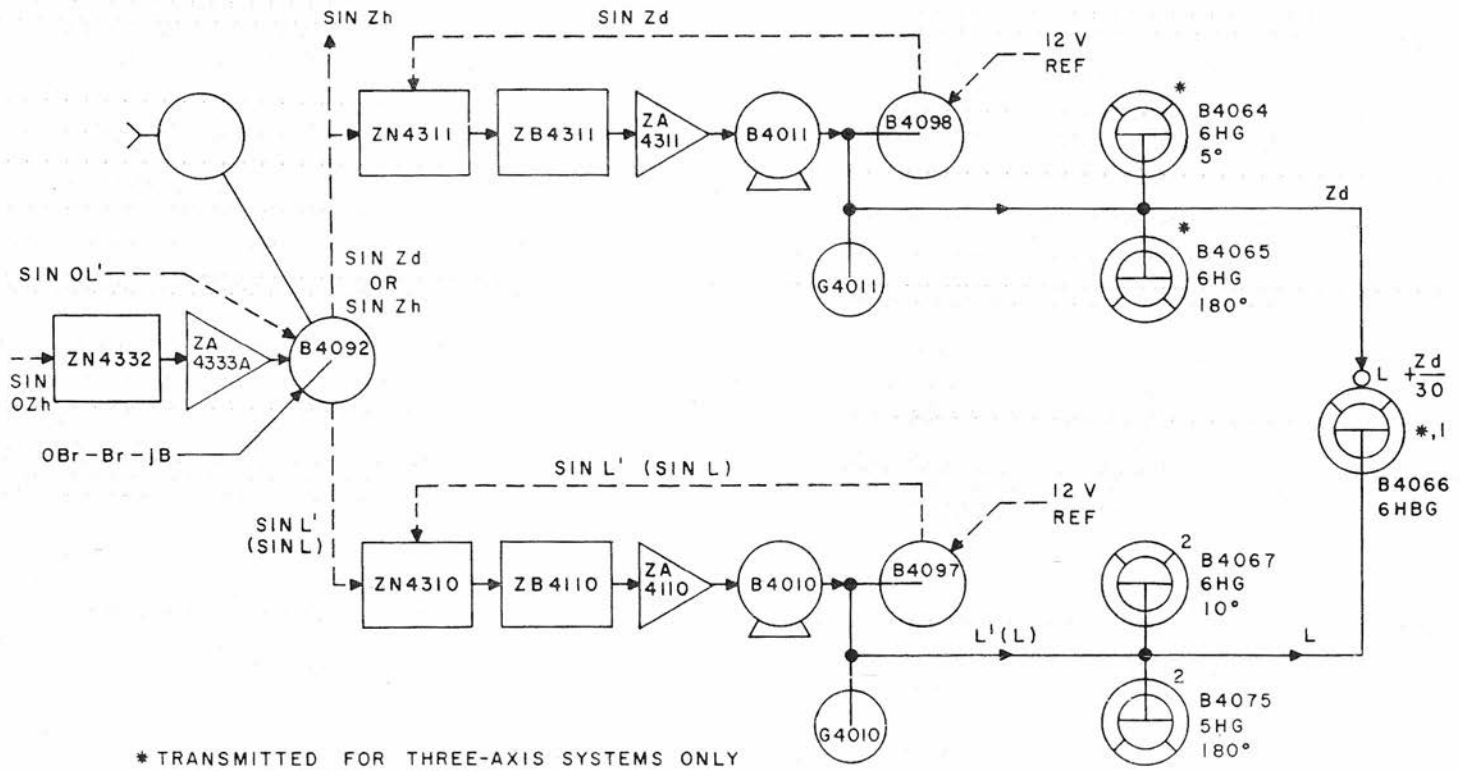

Figure 35. Summation of Target Relative Bearing Terms



- \* TRANSMITTED FOR THREE-AXIS SYSTEMS ONLY
1. TRANSMISSION SPEEDS:
    - 72 x - ARMA DRIVES
    - 36 x - AMPLIDYNE DRIVES
  2. FOR ANTENNA MOUNT Mk 23 ONLY

Figure 36. Computation of Reference LOS Deck-Tilt Angles

the 180- and 5-degree (2- and 72-speed) synchros in Stable Element Mk 6 used in the AA fire control system. Switch S4002 is used also to reverse the phase of computing voltages where the mathematics of the problem involved require a reversal of sign. This is the case in the outputs of resolvers B4089 and B4093, figures 32 and 33, where the voltages going to the associated networks represent mathematical quantities. Owing to the difference in the solutions for an AA or an MB system, either a reversal of the signs of the resolver output or a reversal of the signs of all the other quantities, when switching from one system to the other, is required. The same consideration is involved in one additional case, figure 33, where the reference voltage to the servo control is reversed in phase, causing the associated servo motor to run in the opposite direction (adding or subtracting in differential H40D4, figure 34), depending on which system is in use.

#### Reference-Point Deck-Tilt Computation

Normally, the level and cross-level quantities required for the director originate in the stable vertical (or stable element), but since, in this particular problem, the stable vertical train input, train-to-target, is not the same as director train, the measured values of level and cross level are not directly usable for stabilizing the director. To satisfy the director requirements, values of level and cross level based on the reference line of sight, computed by Computer Mk 48 Mod 1. These quantities are computed for both AA and MB use, but only Gun Director Mk 37 makes use of all three. Due to differences in system design, the computed value of level,  $L'$ , is employed only during MB operation and the values of cross level,  $Zd$ , and level plus a function of cross level,  $L + Zd/30$ , are used only by AA Gun Director Mk 37.

The true-solution equations for main-battery quantities from which the mech-

anized approximations are derived are as follows:

$$\sin L' = \sin OL' \cos(OBr - Br - jB) + \cos OL'$$

$$\sin(OBr - Br - jB) \sin OZh$$

and

$$\sin Zh = \cos Zh \tan OZh \cos(OBr - Br - jB)$$

$$\frac{\tan OL'}{\cos OZh} (OBr - Br - jB)$$

The approximations used in Computer Mk 48 Mod 1 are:

$$\sin L' = \sin OL' \cos (OBr - Br - jB)$$

$$+ \sin (OBr - Br - jB) \sin OZh$$

and

$$\sin Zh = \sin OZh \cos(OBr - Br - jB)$$

$$- \sin OL' \sin (OBr - Br - jB)$$

The corresponding AA equations to compute  $\sin L$  and  $\sin Zd$  are:

$$\sin L = \sin OL \cos(OBr - Br)$$

$$+ \sin (OBr - Br) \sin OZd$$

and

$$\sin Zd = \sin OZd \cos(OBr - Br)$$

$$- \sin OL \sin(OBr - Br)$$

The MB relationships are instrumented to compute  $L'$  and  $Zh$  as shown in figure 36. With reference to the figure,  $\sin OL'$  and  $\sin OZh$ , previously derived, form the electrical inputs to resolver B4092, and the angle  $OBr - Br - jB$ , from differential H40D3, mechanically positions the resolver rotor. The terms in the right-hand sides of the simplified equations shown above are established in the resolver from the inputs

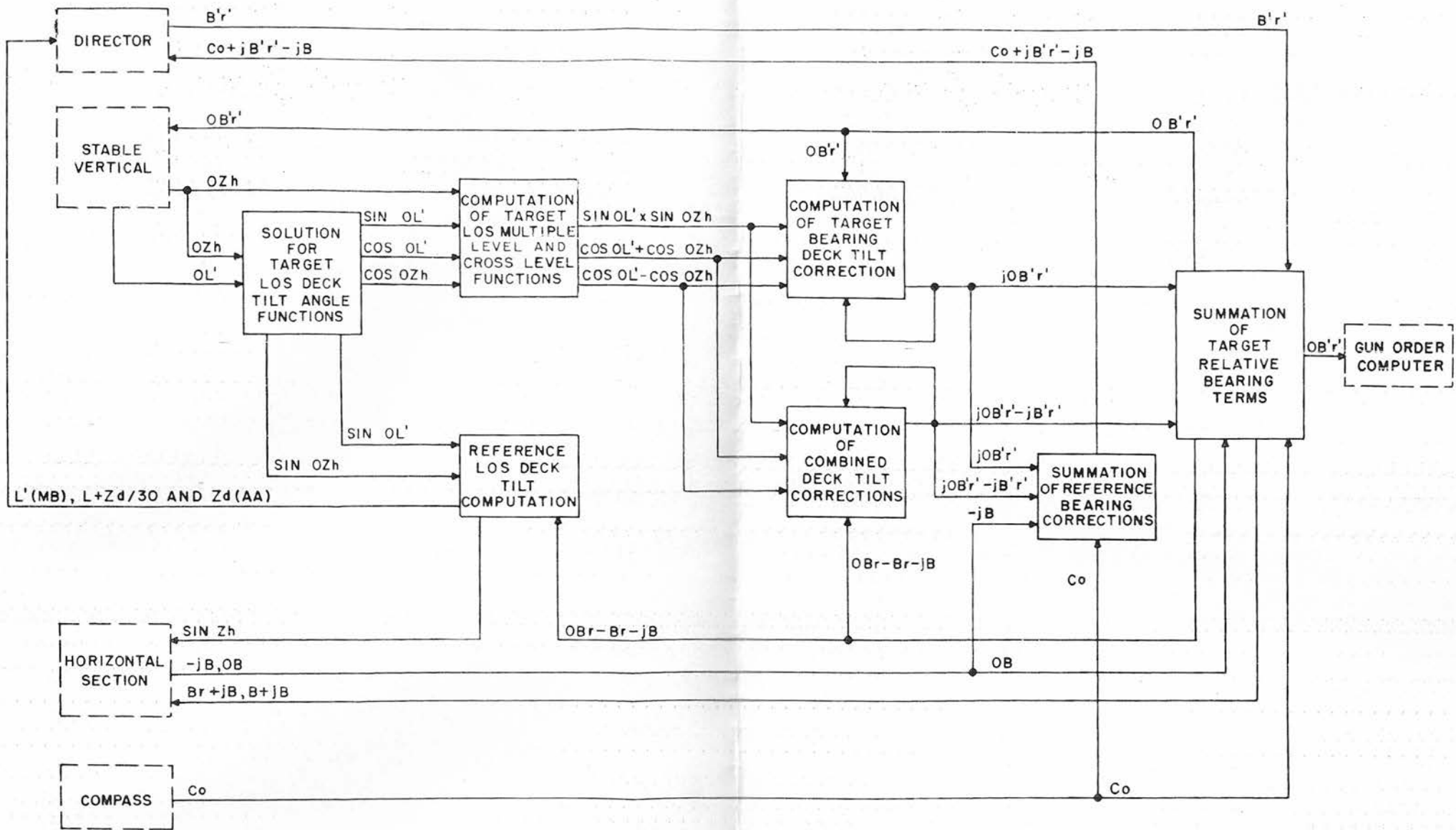

Figure 37. Flow Diagram of Deck-Tilt Section

by the configuration of the wiring and the phasing, so that the resolver outputs are equivalent to  $\sin L'$  and  $\sin Zh$ . These outputs are servoed individually, the loop response being taken from the sine winding of a resolver in each loop. The output of

resolver B4097 will null the  $Zh$  loop when the servo motor has driven the rotor of B4098 to an angle equivalent to  $Zh$ . Synchros for transmitting  $L'$  and  $Zh$  to a director are connected mechanically to their respective loop servo motors.

## Chapter 5

## MAINTENANCE

This chapter contains the tests and maintenance procedures needed to ensure satisfactory operation of Computer Mk 48 Mod 1. It is written primarily for personnel already familiar with fire control and standard electronic test equipment.

The tests and maintenance procedures are divided into five sections:

## Section 5.1—Cleaning and Lubrication

## Section 5.2—Routine Tests

## Section 5.3—Trouble Shooting

## Section 5.4—Electronic Unit Trouble Shooting

## Section 5.5—Adjustments

All pertinent data considered too lengthy or detailed for inclusion in a section have been assembled in the appendix for easy reference.

## Section 5.1—Cleaning, Lubrication, and Inspection

## SCHEDULE

The computer should be cleaned, lubricated, and inspected every 1000 hours of operation, as registered by the time meter.

The time meter records the total number of hours the computer has been in ON operation. It is located behind the front panel cover below network box ZN4141, as shown in figure 63. The indicator is useful when planning tests, maintenance, cleaning, lubrication, and inspection schedules. It also provides data for keeping an accurate log of the performance of duties prescribed by ship's doctrine.

## CLEANING

Before the instrument is lubricated, it must be cleaned of all metal chips, dirt,

dust, and lint. Cleaning should be done with a vacuum cleaner and with a lint-free cloth or brush dipped in white kerosene, MIL-K-3128 (or Deobase, L. Sonneborn and Sons). To avoid the possibility of the cleaning solvent draining onto other units and remaining there, the cleaning process should start at the top of the instrument and progress toward the bottom. The use of compressed air within the instrument is not recommended, because it is liable to blow loose dirt into bearings and onto gears. When cleaning the electronic sections, a long, bristled brush can be used to dislodge accumulated dust into the vacuum cleaner pick-up hose. The solvent, applicators, and other cleaning accessories should be kept clean and free from dirt and chip contamination.

## LUBRICATION

After the cleaning operation has been completed and all the solvent has been removed, lubrication should be performed systematically. Fully lubricating one section or area in the instrument before going on to the next helps to avoid missing any of the important points. The lubricating information that follows is presented in the form of detailed instructions for each type of basic mechanism or basic part that requires lubrication. After lubrication, rotate the pertinent shafts and working parts to distribute the lubricant evenly; then wipe away all excess grease and oil with a clean, lint-free cloth.

## Lubricants

**Grease.** Where grease is needed, use Instrument Lubricating Grease, MIL-G-15793.

**Oil.** Where oil is needed, (except in time-motor regulator) use Instrument Lubricating Oil, MIL-L-6085A.

**Chronometer Oil.** For time-motor regulator, use Wm. F. Nye chronometer oil, except on ball bearings.

## Detailed Lubricating Instructions

Instructions for the routine lubrication of the components are as follows:

**Component Solvers.** Apply a thin coating of grease to the sliding surfaces, slots, and racks. Apply 3 to 5 drops of oil to each bearing, roller groove, and pivot point.

**Integrators.** Apply a thin coating of grease to all working parts and surfaces of the integrator. Apply 3 to 5 drops of oil to all bearings, except those that support discs. The discs should be lubricated with grease whenever integrators are disassembled.

**Limit Stops.** Apply a thin coating of grease to the threads, and run the nut the full length of limit-travel several times to distribute the grease evenly.

**Differentials.** With differentials that have spider shafts less than 1/4 inch in diameter, lubricate the gears and bearings with oil. With differentials that have larger shaft diameters, apply a thin coating of grease to all gearing. Apply about 3 drops of oil to each bearing to form a protective film.

**Gears.** Apply a thin coating of grease to all servo motor pinions, and all gears within three meshes of the motor pinions. Grease all gearing driven by the time motor, and all gearing between the Xp and Yp servo motors and the plotter lead screws. On all other gears, apply enough oil to the gear teeth to form a protective film.

**Bearings.** Apply 3 to 5 drops of oil to all bearings.

**Couplings.** Apply a thin coating of grease to all pressure contact surfaces.

**Worm and Worm Wheels.** Apply a thin coating of grease to the gear teeth.

**Plotter Lead Screws.** Apply a thin coating of grease to the lead screws.

**Time-motor Regulator.** Apply 3 drops of oil (MIL-L-6085A) to all ball bearings. To each jewel bearing and to the worm-gear mesh, apply Wm. F. Nye chronometer oil, sparingly.

## INSPECTION

During the normal course of cleaning and lubricating, all gears and other mechanical parts should be inspected for evidence of damage or abnormal wear due to binding, improper alignment, or presence of foreign material. Similarly,

components in the electronic section should be checked for dust accumulation and signs of trouble, such as charring, fraying of insulation, and bleeding of potting compound or capacitor oil. Before repairing or replacing the affected parts, inspection should be extended to determine the cause of the damage so that the possibility of recurrence can be eliminated.

Air filters are installed at the air intakes of the cooling system to prevent the cooling air from carrying dirt into the electronic portion of the instrument. They should be inspected periodically, and cleaned or replaced when necessary.

Section 5.2— Routine Tests

The functional condition of the computer should be known at all times. The routine tests that follow are the only practical means for checking its overall accuracy. If the results obtained during the performance of these indicate a need for computer maintenance, refer to trouble shooting, section 5.3.

- A Tests . . . .BuOrd Dwg 456326
- All other tests . NAVORD OD 10522  
(under preparation)

Prior to every routine test or firing problem, check the serviceability of the neon indicator lights, and by means of the neon monitoring system and voltmeters, determine if the electronic elements and power supply units are functioning correctly (see section 5.3). Each of the routine tests is designed to check particular sections of the computer. However, the same fundamental method is used for all routine tests. That is, introducing specified inputs, reading resultant outputs, and comparing observed values with calculated values. When all outputs remain within the tolerances, the functional condition of the computer is considered satisfactory.

FREQUENCY OF TESTS

The recommended frequency for performance of routine tests is as follows:

Frequency of Test	Routine Test
Daily (one problem)	A Tests
Weekly	Generation of $\Delta X_o$ and $\Delta Y_o$
Weekly	Generation of $\Delta cR$
Weekly	Test of transmission units (except Ph and $\Delta cR$ )
Monthly	Test of Ph and $\Delta cR$ transmitters
Monthly	Time-motor regulator test
Monthly	Index-light travel test

LIST OF TEST-FORM DRAWING NUMBERS

The routine tests are based on information taken from factory tests. Copies of these tests may be requisitioned from the Naval Gun Factory, Washington 25, D.C. The tests are identified as follows:

## TEST INPUT SETTINGS

All output quantities from the computer are direct functions of their respective input quantities. Therefore, no attempt at trouble analysis should be based on test results derived from input settings not made with systematic uniformity and accuracy.

In the absence of specific instructions, an input should be set by turning its input control in the direction that causes its dial to move in an increasing direction, that is, from a lower value to a higher one. If an input is accidentally run beyond the checkpoint, return the dial to the negative side of the value and, turning the dial more slowly than previously, carefully approach the setting again. Exercising such uniformity and exactness with the input setting will result in constant, reliable, and uniform test readings from which instrument performance can be evaluated correctly.

## CALCULATION OF ERRORS

To calculate a test error, subtract algebraically the calculated value from its observed value. The following examples may be used as a guide:

Calculated Value	Observed Value	Test Error (in mins)
60°00'	60°03'	+3
60°00'	59°58'	-2
-60°00'	-60°06'	-6
-60°00'	-59°59'	+1

### Average Error

To calculate the average error, first add the individual errors without regard to signs, then divide the sum by the number

of errors recorded. The quotient will be the average error for each quantity. The average of the errors in the preceding tabulation would be 3 minutes.

### Maximum Error

To determine the maximum error, select the largest reading of all the readings recorded. The maximum error of the errors in the preceding tabulation would be 6 minutes.

### Allowable Limits

To determine whether the errors are permissible, compare the average and maximum errors with the allowable average and maximum values given on the test form for that particular quantity. If the recorded values are within the error range allowed, the test should be considered satisfactory. If the results exceed the range allowed, the test is unsatisfactory and reference should be made to the appropriate test analysis in section 5.3 of this chapter.

### Procedure for Excessive Errors

Whenever output errors are excessive, perform an analysis of the errors to determine the exact cause, and immediately take measures to correct it. If the output errors are the direct result of an improper test setup, correct the test setup and repeat the entire test. If the output errors are not caused by an improper test setup, but by the computer itself, refer to the trouble shooting section of this chapter to determine the causes and remedies. After an element has been replaced with a new one, repaired or adjusted, always perform a complete set of tests to be certain the instrument is in satisfactory condition.

## A TESTS

The A tests are static tests and are made to check all computing mechanisms, except those requiring a time input. They test the condition of the interconnection of dials and counters to the input and output shafts, the operation of the various computing elements involved, and the functional accuracy resulting from established adjustments between the various elements.

Tables 12 and 13 give the independent variables, or inputs, and the transmitted quantities, or outputs, respectively, for the sixteen A test problems. The test procedure, basically, involves introducing a prescribed set of input quantities into the computer, reading the resultant outputs, and entering the test results in the appropriate columns on the test form. When discrepancies between observed and calculated values exceed the tolerances, reference should be made to A Test Trouble Analysis in section 5.3.

Since each A test problem is designed to place critical stress on a limited number of the computing elements, no single problem or partial A test proves the functional accuracy of the computer as a whole. The computer is not proven completely until all the A tests have been run and found to be satisfactory.

## Problem Setup

Certain quantities listed for the A test problems cannot be read on an external dial or counter on the computer. Therefore, to facilitate running a set of problems without removing the covers, use the test unit and some of the indicating devices in the director and on the stable vertical.

The A test values for Ph and X and Y coordinates were devised to be read as voltages, using the test unit as the measur-

ing device. For these quantities, the SIGNAL TEST SELECTOR switch on the computer is set at the position prescribed on the A test form, and the resultant outputs are read from the dials of the test unit. Refer to Test Unit, page 103 for a complete operational description of this instrument.

Offset level and cross level are the only A test inputs without any hand input facilities on the computer. They must be introduced at the stable vertical and fed into the computer as electrically transmitted inputs. The general procedure for these two quantities is to set up the switchboards for transmitting OL' and OZh to the computer and then to set the stable vertical dials manually at the values specified for the A test problem. Similarly, since there are no indicating facilities on the computer for the transmitted values of L', Zh, and  $Co + jB'r' - jB$ , the necessary arrangements must be made for transmitting these quantities to a director and for a director operator to read and report the values received. The complete test procedure may be summarized as follows:

1. Energize the motor-generator set for automatic operation, as explained in chapter 3.
2. Install the removable hand-cranks.
3. Complete the necessary switchboard connections as previously discussed.
4. Throw the computer POWER switch to ON.
5. Check the voltmeters and neon indicator system for correct operation of the computer.
6. Connect the test unit to the computer.

Table 12

## A-TEST INDEPENDENT VARIABLES

Mode	Item	Director Train	Ship Course	Ship Speed	Observed Slant Range	Radar Beacon Delay Spot	Offset Level	Offset Cross Level	Height Point of Aim	Height Target	E-W Spot	N-S Spot	E-W Offset Target From Reference	N-S Offset Target From Reference	E-W Offset Point of Aim From Reference	N-S Offset Point of Aim From Reference	Scale
	Sym- bol	B'r'	Co	So	R	R	OL'	OZh	Hs	Ht	Xj	Yj	Xt	Yt	Xa	Ya	SF
	Unit	Degrees and Minutes	Degs	Knots	Yards	Yards	Minutes 2000 = Zero	Minutes 2000 = Zero	Feet	Feet	Yards	Yards	3A Read.	3E Read.	2F Read.	3C Read.	
M. B.	1	40°00'	20°	0	5000	0	2300	2300	3000	2500	0	0	-0.705	-0.705	-0.235	+0.590	1:25000
A. A.	2	40°00'	20°	0	5000	0	2300	2300	3000	2500	0	0	-0.705	-0.705	-0.235	+0.579	1:25000
M. B.	3	75°00'	110°	0	10, 100	100	1400	2480	4200	1000	0	0	+2.350	+1.880	-0.470	-2.184	1:10000
A. A.	4	75°00'	110°	0	10, 100	100	1400	2480	4200	1000	0	0	+2.350	+1.880	-0.470	-2.091	1:10000
M. B.	5	335°00'	230°	0	16, 400	400	1820	1160	1700	1400	E700	N200	-1.410	0.000	-1.880	-0.625	1:36000
A. A.	6	335°00'	230°	0	16, 400	400	1820	1160	1700	1400	E700	N200	-1.410	0.000	-1.880	-0.710	1:36000
M. B.	7	210°00'	60°	0	14, 200	200	1640	1880	1000	300	E50	N150	-2.444	-0.611	+0.235	-2.318	1:36000
A. A.	8	210°00'	60°	0	14, 200	200	1640	1880	1000	300	E50	N150	-2.444	-0.611	+0.235	-2.277	1:36000
M. B.	9	180°00'	345°	0	20, 000	0	2000	2900	1200	0	W500	N800	0.000	+0.705	-0.151	-2.387	1:25000
A. A.	10	180°00'	345°	0	20, 000	0	2000	2900	1200	0	W500	N800	0.000	+0.705	-0.151	-2.398	1:25000
M. B.	11	250°00'	0°	0	25, 000	0	1100	2000	1500	900	E750	S250	-1.293	+1.175	+0.376	-2.044	1:60000
A. A.	12	250°00'	0°	0	25, 000	0	1100	2000	1500	900	E750	S250	-1.293	+1.175	+0.376	-2.049	1:60000
M. B.	13	10°00'	270°	0	30, 000	0	2000	2000	5000	4700	W400	S700	+4.700	+2.115	-4.465	-1.311	1:36000
A. A.	14	10°00'	270°	0	30, 000	0	2000	2000	5000	4700	W400	S700	+4.700	+2.115	-4.465	-1.311	1:36000
M. B.	15	45°00'	150°	0	-	0	2180	2120	0	300	0	0	+0.423	+0.470	-0.141	+0.585	1:10000
A. A.	16	45°00'	150°	0	-	0	2180	2120	0	300	0	0	+0.423	+0.470	-0.141	+0.577	1:10000

Main battery (M. B.) symbols are used throughout. Problems numbered 1 thru 14 are computed with S4006 at SHORE BOMB SHIP position. Problems numbered 15 and 16 are computed with S4006 at LOCAL CONTROL SHIP position. Xt, Yt, Xa, Ya can be read only as voltage outputs of pots R3012, R4013, R4010 and R4011, respectively. Yards = 20,000 x voltage reading/4.7 for Xt and Yt; + for Xa and Ya. Ph can be read as voltage output of pot R4007. Degs = 1273 x voltage reading/1248.

Table 13

A-TEST TRANSMITTED QUANTITIES

OB'r' Rel. Target Bearing				OR Slant Range to Targ.			Et Target Elevation			* Ph Horizontal Parallax			L' Level					Zh Cross Level				Co + jB'r'-jB Brg. Aid to Ref. Tr'k'g.			Item	Mode			
Theoretical Solution	Instrument Reading	Error		Theoretical Solution	Instrument Reading	Error	Theoretical Solution	Instrument Reading	Error	Theoretical Solution	Instrument Reading	Error	Theoretical Solution	Class "B" Error	Calculated for Instrument	Instrument Reading	Class "A" Error	Theoretical Solution	Class "B" Error	Calculated for Instrument	Instrument Reading	Class "A" Error	Theoretical Solution	Instrument Reading	Error				
Degrees and Minutes	Min.		Yards	Yards	Yds.		Minutes (2000= Zero)	Min.	Read.	iG Read.	Read.		Minutes (2000= Zero)	Min.	Minutes (2000= Zero)	Min.		Minutes (2000= Zero)	Min.	Minutes (2000= Zero)	Min.		Degrees and Minutes	Min.	Units				
50°01'			8775				2327			-0.723			2347	+1	2348			2243	0	2243			9°00'			1	M. B.		
49°56'			8810				2326			-0.723			2347	+1	2348			2243	0	2243			0°11'			2	A. A.		
114°35'			12097				2095			-0.542			1845	+5	1850			2751	+5	2756			7°56'			3	M. B.		
115°26'			12518				2092			-0.542			1851	-1	1850			2752	+4	2756			9°09'			4	A. A.		
276°16'			13568				2118			+0.148			2633	+1	2634			1416	+10	1426			1°47'			5	M. B.		
273°44'			13895				2116			+0.148			2646	-12	2634			1430	-4	1426			9°35'			6	A. A.		
280°17'			13432				2026			+0.201			1765	-1	1764			2298	-1	2297			0°06'			7	M. B.		
279°44'			13216				2026			+0.201			1763	+1	1764			2297	0	2297			9°53'			8	A. A.		
170°20'			12499				2000			0.000			1845	0	1845			2887	-1	2886			5°22'			9	M. B.		
169°39'			12461				2000			0.000			1840	+5	1845			2886	0	2886			5°00'			10	A. A.		
255°11'			19542				2053			+0.211			1103	0	1103			2080	-2	2078			0°38'			11	M. B.		
254°50'			19526				2053			+0.211			1103	0	1103			2078	0	2078			0°19'			12	A. A.		
2°00'			30957				2174			-0.032			2000	0	2000			2000	0	2000			0°00'			13	M. B.		
2°00'			30957				2174			-0.032			2000	0	2000			2000	0	2000			0°00'			14	A. A.		
45°00'			4547				2074			0.000			2180	0	2180			2120	0	2120			9°58'			15	M. B.		
45°00'			4615				2075			0.000			2180	0	2180			2120	0	2120			0°04'			16	A. A.		
Total	Allow.		Total	Allow.		Total	Allow.		Total	Allow.		Total	Allow.		Total	Allow.		Total	Allow.		Total	Allow.		Total	Allow.		Total	Allow.	
Avg.	15		Avg.	50		Avg.	3		Avg.	.025		Avg.	4		Avg.	3		Avg.	3		Avg.	15		Avg.	15		Avg.	15	
Max.	30		Max.	100		Max.	6		Max.	.050		Max.	8		Max.	6		Max.	6		Max.	30		Max.	30		Max.	30	

\* Read Voltage at Voltage Check Point 1G.

7. Set in OL' and OZh at the stable vertical.

8. Throw the computer DIRECTOR SELECTOR switch to MB or AA, as required for the problem, and set in the remaining independent variables.

9. Read and record the transmitted outputs as follows:

- a. Read OB'r', OR, and Et on Computer Mk 48 Mod 1 dials.
- b. Read Ph on the test unit dial.
- c. Notify the director operator to read and report the received values of L', Zh, and Co + jB'r' - jB.

2. Install Co and So handcranks.

3. Set the mode-and-plot switch to LOCAL CONTROL SHIP.

4. Throw the POWER switch to STANDBY.

5. Place blank paper on the plotter and tape it securely in place.

6. Throw the TIME switch to ON.

7. Throw the POWER switch to ON.

8. Check the voltmeters and neon system for correct operation of the computer.

9. Check the stop-watch against the ship's chronometer.

#### GENERATION TESTS

The generation tests are performed to check the generating mechanisms of the computer: namely, the  $\Delta X_0$ ,  $\Delta Y_0$ , and  $\Delta cR$  integrators, and the rate-computing mechanisms, the Co and Br mechanical resolvers.

Tables 14 and 15 are the test forms to be used in running the 10 generation problems. A problem consists of introducing predetermined input quantities into the rate-computing mechanism under test, running the time input for a specified period, and measuring the accumulated changes in the generated quantity. When the test-result errors exceed the specified tolerances, refer to Generation Test Analysis, pages 142 through 145.

Test for Generation of  $\Delta X_0$  and  $\Delta Y_0$

#### Problem Setup.

1. Energize the motor-generator set for automatic operation.

#### Procedure.

1. Crank in the scale factor specified in column 3, table 14.

2. Crank in Co and So as specified in columns 1 and 2.

3. Determine the direction of index-light travel from column 1, and draw a travel-line at the prescribed angle of sufficient length to exceed the five-minute run.

4. Draw a straight line perpendicular to the line-of-travel, near the start end.

5. From the start line, measure off the exact distance the index light should travel in five minutes, as given in columns 4 and 5, and draw a finish line perpendicular to the travel line. For problem two (Co set at 45 degrees), measure off 4.75 inches to the right from the start line (running parallel to the edge of the plotter), and then 4.75 inches straight up to the finish point.

Table 14

TEST FOR GENERATION OF  $\Delta X_0$  AND  $\Delta Y_0$ 

Settings		Measurements			Results		
1	2	3	4	5	6	7	8
Co	So Knots (yds/sec)	Scale Factor	Xo inches (yds)	Yo inches (yds)	*Total Time	Error (sec)	Error (yds/sec)
0°	14.8 (8.33)	10,000:1	0.00 (0)	9.00 up (2500)			
45°	27.6 (15.54)	25,000:1	4.75 right (3299)	4.75 up (3299)			
90°	35.5 (19.99)	36,000:1	6.00 right (6000)	0.00 (0)			
180°	45.2 (25.45)	50,000:1	0.00 (0)	5.50 down (7639)			
270°	54.7 (30.80)	70,000:1	4.75 left (9236)	0.00 (0)			
						Allow Error	0.25

\*Calculated computer-time is five minutes.

6. With the start and finish lines drawn, bring the index light onto the line of travel, well ahead of the start line.

7. As the index light just crosses the start line, start the stop watch.

8. As the index light (about five minutes later) just crosses the finish line, stop the stop watch and note the exact time taken for the light to travel from the start to the finish line.

9. Enter this total time in column 6, and the error (seconds from five minutes) in column 7.

10. Substitute this last error, and the value of So in yards per second in the following formula:

Error in yards per second =

$$\frac{\text{So (yards per second)} \times \text{Error (seconds)}}{300}$$

11. Solve for the error in yards per second, and enter this error in column 8.

### Test for Generation of $\Delta cR$

#### Problem Setup.

1. Energize motor-generator set for automatic operation.
2. Install B'r' and So handcranks.
3. Throw POWER switch to STAND-BY.
4. Set Co, OL', and OZh at zero degree; Hs at zero feet; and Rj at OFF.
5. Set the mode-and-plot switch at SHORE BOMB SHIP.
6. Arrange phone communication with a director for purposes of  $\Delta cR$  test information.
7. Throw the POWER switch to ON.
8. Check the voltmeters and neon system for correct operation of the computer.
9. Check the stop watch against the ship's chronometer.

#### Procedure.

1. Throw the TIME switch to ON. Allow the time motor to run for at least a minute before proceeding with test.
2. Set in values for So and B'r', as specified in columns 1 and 2, table 15.
3. Instruct the director operator to select a starting range value that will allow running the problem without reaching a limit.

4. Instruct the director operator to read the fine range dial and to start the stop watch just as the fine range dial passes through its zero mark, and to stop the watch just as the required range change is completed.

NOTE: This test can be conducted without aid from the director if cover No. 5 is removed. With cover No. 5 removed, the  $\Delta cR$  dial can be read directly.

5. Enter the total time taken to run the particular problem in column 7.

6. Enter the error in seconds in column 8 (observed time minus calculated time in sixth column).

7. Substitute these last two entries, plus the other values that affect the problem, into the following formula:

$$\Delta cR \text{ error (yds/min)} =$$

$$\frac{\text{So (yds/sec)} \times \cos B'r' \times \text{error (sec)}}{\text{time} \times 60}$$

8. Solve for the error in yards per minute, and enter this error in column 9.

### TRANSMISSION TESTS

These tests, shown in tables 16 to 21, are used to check the accuracy of each receiver and transmitter throughout its range of operation. The basic procedure involves:

1. Setting a synchro transmitter at prescribed angular checkpoints.
2. Reading the received value at the corresponding receiver.
3. Calculating the errors by comparing the received values with the specified transmitted values.

Table 15  
TEST FOR GENERATION OF  $\Delta cR$

Setting			Output			Results		
1	2	3	4	5	6	7	8	9
So Knots (Yds/sec)	B'r'	Cos B'r'	$\Delta cR$ Yds	$\Delta cR$ Dial Reading	Time Min Sec	Time Stop-Watch Min Sec	Error Sec	Error Yds/Min
10 (5.63)	30°00'	.8660	-980	20	3:21			
25 (14.075)	135°00'	.7071	+2000	2 Rev and 0	3:21			
35 (19.705)	180°00'	1.0000	+2660	2 Rev and 660	2:15			
45 (25.335)	240°00'	.8660	+2800	2 Rev and 800	3:41			
55 (30.965)	345°00'	.2588	-3290	3 Rev and 710	1:50			
							Allow Error	20

In checking each of the Computer Mk 48 Mod 1 transmission units, it therefore is necessary to perform switching operations at the main and shore bombardment auxiliary switchboards to connect the unit under test with its related unit in another system component. It also is necessary to energize both system components involved in the test. Thus, each test of a Computer Mk 48 Mod 1 transmission unit is actually a test of a complete transmission circuit

involving a transmitter, wiring, a switchboard, and a receiver.

When running these tests, approach each checkpoint slowly from both directions, that is, from the lower numbers to the checkpoint, and then from the higher numbers. The spread between the increasing and decreasing readings is an indication of receiver sensitivity as well

as the condition of the mechanism of the receiver and the load it drives.

### Receiver Accuracy Test

The six receivers in Computer Mk 48 Mod 1 are checked for accuracy by transmitting to them the values listed in table 16. In the case of the level and cross-level receivers, no direct means of indicating received values is provided on the computer. Therefore, in addition to angles to be transmitted from the stable vertical, table 16 lists voltage values representing the outputs of electrical resolvers whose rotors are positioned by the OL' and OZh receivers. Assuming correct resolver functioning, the voltage readings serve as an accurate indication of the received angles. The checkpoint voltages are indicated by means of the test unit with the computer test-point selector switches positioned as indicated in the table.

### Receiver Synchronization Test

This portion of the transmission test checks the ability of the six receivers to drive from a position displaced from synchronism to a stable synchronized condition in the specified length of time. Test results are dependent upon the functional condition and adjustment of associated electronic elements as well as the receiver proper and the load it drives.

The following procedure should be used for running the synchronization tests:

1. Throw DIRECTOR SELECTOR switch to MB.
2. Energize the transmission circuit to be tested.
3. Position the transmitter at a value from which the receiver can syn-

chronize through the specified displacement and in the specified direction, as given in table 17. Be sure the receiver synchronizes at this value.

4. De-energize the circuit, and displace the transmitter from synchronism by the amount specified in table 17. Where 180-degree displacements are specified, add or subtract a degree or two as required to assure synchronization in the specified direction (increase or decrease).

5. Again energize the circuit, and simultaneously press the start button of a stop watch.

6. Stop the watch the instant the receiver stops oscillating at the synchronization point.

7. Record the elapsed time on the test form, and compare it with the maximum allowable value.

### Accuracy Test of OB'r', OR, Et, and Ph Transmitters

The checkpoint values for this group of transmitters, table 18, can be set up indirectly by handcrank, with the computer energized. Use the B'r' handcrank for OB'r', the R handcrank for OR, the Ht handcrank for Et (R at low value), and the B'r' handcrank for Ph (R at low value). Approach each checkpoint value from both directions. Cover No. 6 must be removed for access to the Ph transmitter dial.

### Accuracy Test of $\Delta$ cR Transmitter

Performance of this test requires removal of cover No. 5 for access to the  $\Delta$  cR transmitter dial and operation of the computer time motor. Since the test primarily is concerned with transmitted changes in range rather than static checkpoints, each of the four values given in table 19 represents the difference between

Table 16

RECEIVER ACCURACY TEST

Ship Speed Receiver (So)

Transmitter Knots	Increasing		Decreasing	
	Computer Reading	Error	Computer Reading	Error
5				
10				
15				
20				
25				
30				
40				
55				
	Sub Total		Sub Total	
			Total	
Value 40 Knots			Avg Err	0.1
			Max Err	0.2

Allow

Table 16 (Cont'd)  
RECEIVER ACCURACY TEST

Ship Course Receiver (Co)

Transmitter Deg and Min	Increasing		Decreasing	
	Computer Reading	Error	Computer Reading	Error
0°00'				
59°00'				
118°00'				
177°00'				
236°00'				
295°00'				
354°00'				
	Sub Total		Sub Total	
			Total	
			Avg Err	3
			Max Err	5

Values 10° and 360°

Allow

Table 16 (Cont'd)

RECEIVER ACCURACY TEST

Director Train Receiver (B'r')

Transmitter Deg and Min	Increasing		Decreasing	
	Computer Reading	Error	Computer Reading	Error
0°00'				
59°00'				
118°00'				
177°00'				
236°00'				
295°00'				
354°00'				
	Sub Total		Sub Total	
			Total	
			Avg Err	2
			Max Err	4

Values 10° and 360°

Allow

Table 16 (Cont'd)  
RECEIVER ACCURACY TEST

Range Receiver (R)

Transmitter Yards	Increasing		Decreasing	
	Computer Reading	Error	Computer Reading	Error
600				
3350				
6700				
10,050				
16,750				
25,900				
37,600				
50,000				
	Sub Total		Sub Total	
			Total	
			Avg Err	5
			Max Err	10

Values 2000 and 720,000 yds

Allow

Table 16 (Cont'd)

RECEIVER ACCURACY TEST

Offset Level Receiver (OL')

Trans Mins	B4083 5B Read	Increasing		Decreasing	
		Computer Reading	Error	Computer Reading	Error
560	-4.881				
1280	-2.495				
1640	-1.254				
2000	0				
2360	+1.254				
2720	+2.495				
3440	+4.881				
		Sub Total		Sub Total	
				Total	
				Avg Err	0.010
				Max Err	0.020

2000 = 0 min

Values 10° and 180°

Allow

Table 16 (Cont'd)  
RECEIVER ACCURACY TEST

Offset Cross-Level Receiver (OZd) AA

Trans Mins	B4084 5E Read	Increasing		Decreasing	
		Computer Reading	Error	Computer Reading	Error
560	-4.881				
1280	-2.495				
1640	-1.254				
2000	0				
2360	+1.254				
2720	+2.495				
3440	+4.881				
		Sub Total		Sub Total	
				Total	
2000 = 0 min				Avg Err	0.010
Values 5° and 180° AA				Max Err	0.020

Allow

Table 16 (Cont'd)

RECEIVER ACCURACY TEST

Cross-Level Receiver (OZh) MB

Trans Min	B4084 5E Read	Increasing		Decreasing	
		Computer Reading	Error	Computer Reading	Error
560	-4.881				
1280	-2.495				
1640	-1.254				
2000	0				
2360	+1.254				
2720	+2.495				
3440	+4.881				
		Sub Total		Sub Total	
				Total	
2000 = 0 min				Avg Err	0.010
Values 10° and 180° MB				Max Err	0.020

Allow

Table 17

## RECEIVER SYNCHRONIZATION TEST

Receiver	Displacement	Direction	Time (Sec)	Max Allow
Ship Course (Co) 1x, 36x 1HCT's	180°	Incr Decr		9 sec
Ship Speed (So) 40 knots	20 kn	Incr Decr		5 sec
Director Train (B'r') 1x, 36x 1HCT's	180°	Incr Decr		9 sec
Range (R) 2000 yds, 72,000 yds 1HCT's	36,000 yds	Incr Decr		9 sec
Offset Level (OL') 2x, 36x 1HCT's	25°	Incr Decr		4 sec
Offset Cross Level (OZh) 2x, 36x 1HCT's	25°	Incr Decr		4 sec

Table 18

## ACCURACY TEST - DIRECT READING TRANSMITTERS

Quantities and Symbols	Values	Check Points				Max Allow
Relative Target Bearing (OB'r')	10° and 360°	59°	118°	236°	354°	2 min
Slant Range to Target (OR)	2000 and 72,000 yds	1000 yds	10,400 yds	20,100 yds	39,950 yds	7 yds
Target Elevation (Et)	360 mils	60 min	360 min	720 min	1080 min	5 min
Horizontal Parallax (Ph)	30°/100 yds	-10°	-2°	+2°	+10°	6 min

Table 19

ACCURACY TEST -  $\Delta$ CR TRANSMITTER

Quantity	Values	Check Points				Max Allow
Increments of generated range	1000 yds/rev	+200 yds	+400 yds	+600 yds	+800 yds	5 yds

a start-reading and a finish-reading. That is, at the start, readings are taken of the transmitter dial and the receiver dial in the director; the time motor is operated until the transmitter has been driven through the required change and stopped; and the receiver dial in the director again is read to obtain the received change. For the two minus runs (decreasing changes), set B'r' at 0 degrees, and for the two plus runs (increasing changes) set B'r' at 180 degrees. The value of ship speed can be varied as a means of control in producing the changes. For example, a high speed can be used for the greater part of the run followed by a low speed as the run nears completion and a zero speed setting to stop the generation as the required change is completed.

#### Test of L', Zd, and L' + Zd/30 Transmitters

Because these transmitters lack facilities for direct control of the transmitted values, it is necessary to use the OL' and OZh manual controls at the stable vertical for selecting test values, and to use the test unit for indirectly indicating the values selected. The received quantities are checked at a director. Table 20 lists the SIGNAL TEST SELECTOR switch points corresponding to the quantities under test, the voltage values that must be set up to position the transmitters, and the corresponding transmitted angles that the receivers must indicate. After arranging

for transmission between the stable vertical and the computer and between the computer and the MB director, the following steps can be performed:

1. With mode-and-plot switch at SHORE BOMB TGT, mark location of plotter index light.
2. Throw mode-and-plot switch to SHORE BOMB REF and, using the REF-SHIP coordinate handcranks, return the index light to the position marked in step 1.
3. Connect the test unit.
4. With the computer SIGNAL TEST SELECTOR switch set at 7D, adjust the manual level input at the stable vertical to obtain the voltage values listed in table 20 on the test-unit dials.
5. For each voltage setting, compare the reading on the MB director level receiver dials with the value given in the table.
6. With the SIGNAL TEST SELECTOR switch at 7C, adjust the manual cross-level input at the stable vertical to obtain the voltage values listed in table 20 on the test-unit dials.
7. For each voltage setting, compare the reading on the MB director cross-level receiver dials with the value given in the table.

Table 20

## ACCURACY TEST - DIRECTOR LEVEL AND CROSS LEVEL

Check Points	Value	1	2	3	4	Max Allow
Test Unit Reading		-4.104	-1.046	+1.046	+4.104	
Director Receiver Reading	10° and 180°	-20°	-5°	+5°	+20°	6 min

8. Set and hold cross level at a value that gives a zero voltage indication on test-unit dials.

9. Set SIGNAL TEST SELECTOR switch at 7D, and adjust manual level input at stable vertical to obtain voltage values listed in the table on the test-unit dials.

10. For each voltage value, compare the reading on the director L' + Zd/30 dials with the value given in the table.

#### Test of Co + jB'r' - jB Transmitter

When testing the bearing-tracking-aid transmitter, two of the quantities, jB'r' and jB, are held at zero, the Co dials are set at the check points, table 21, by means of the Co handcrank, and the values received at the director are compared with those transmitted. To zero jB, throw the computer DIRECTOR SELECTOR switch to AA. To zero jB'r', transmit zero values of level and cross level from the stable vertical to the computer receivers.

#### TIME MOTOR REGULATOR TEST

Proper operation of the time motor regulator is determined by checking the speed

of the time line with a stop watch. Use the test form shown in table 22. The time motor test is summarized as follows:

1. Remove cover No. 5 from the computer to gain access to the time counter.
2. Turn the mode-and-plot switch to LOCAL CONTROL SHIP.
3. Place the Xa and Ya handcranks at normal disengaged position.
4. Set B'r' at zero, Co at 45 degrees, So at 25 knots, OL' at zero, and OZh at zero.
5. Throw the POWER switch to ON.
6. Throw the TIME switch to ON. Allow the time motor to run at least one minute before proceeding with the test.
7. Check that the control power voltage to the regulator is 115 volts.
8. As a starting reference number, select a convenient whole number that will appear shortly on the time counter. As the reference number exactly coincides with the counter-index mark, start a stop watch. When the time counter indicates that exactly 10 minutes have elapsed, stop

Table 21

## ACCURACY TEST - TRAIN CONTROL

Transmitter	Values	Check Points				Max Allow
Train Control	5° and 10°	59°	118°	236°	354°	5 min

Table 22

## TIME MOTOR REGULATOR TEST

*Time Cal Min Sec	Time Stop-Watch Min Sec		Error		
			Sec	Sec/Min	Allow
10'00.0"					0.05

\*Calculated time is for 1000 revolutions of regulator shaft.

the watch, and read the elapsed time in seconds and tenth-seconds. If the watch reads more than 10 minutes, then the time line is slow. If the watch reads less than 10 minutes, the time line is fast.

9. If results indicate that the time-motor regulator needs adjustment, refer to OP 1140A, Basic Fire Control Mechanisms-Maintenance for adjustment procedures.

## INDEX-LIGHT TRAVEL TEST

Although the purpose of this test is to determine the accuracy of the plotter gearing, the test results also will reflect upon the operation of those elements shown in figure 51. The quantities  $R_h \sin B$ , and  $R_h \cos B$ , however, are grounded out in this test.

To insure that the test results will be accurate, start the test with all lost motion taken up. When moving to the stop line, stop the light exactly on the line. Any movement beyond the stop line will affect the lost motion accumulated and result in an inaccurate test reading. When moving the light back to the start line, stop the light exactly on the line.

## Test for Index-Light Travel

## Problem Setup.

1. Energize the motor-generator set for automatic operation.
2. Connect the TEST UNIT to computer.
3. Throw the POWER switch to STANDBY.

4. Throw the DIRECTOR SELECTION switch to MB.

5. Set the SCALE FACTOR at 25,000:1.

6. Set the mode-and-plot switch at SHORE BOMB REF.

7. Remove cover No. 1 from the plotter.

8. Place a blank paper on the plotter and tape it securely in place.

9. Throw the POWER switch to ON.

10. Check the voltmeters and neon system for correct operation of the computer.

#### Procedure.

#### Test for Xp Travel (Run No. 1).

1. Turn TEST SELECTOR switch to 2F.

2. Turn the Xa handcrank to position Xp counter at 20.00, as shown in column 1, table 23.

3. Turn the Ya handcrank to position Yp counter at 2.00.

4. Read the TEST UNIT voltage, and enter the value in column 6, top line.

5. Draw a vertical start line (perpendicular to the front of computer) through the index light.

6. Draw a vertical stop line parallel to the start line exactly 12 inches to the right of the start line.

7. Turn the Xa handcrank to position the index light exactly on the stop line.

8. Read the Xp counter and enter the value in column 3, top line.

9. Read the TEST UNIT voltage and enter the value in column 9, top line.

10. Enter the voltage reading of step 9 in column 6, second line.

11. With the Xa handcrank, return the index light to the start line.

12. Read the Xp counter, and enter the value in column 3, second line.

13. Read the TEST UNIT voltage, and enter the reading in column 9, second line.

14. Calculate the error in inches and enter the results in the appropriate error columns.

#### Test for Yp Travel (Run No. 2).

1. Turn the TEST SELECTOR switch to 3C at the computer.

2. Turn the Ya handcrank to position the Yp counter at 2.00.

3. Turn the Xa handcrank to position the Xp counter at 16.4.

4. Read the TEST UNIT voltage, and enter the value in column 6, top line.

5. Draw a horizontal start line (parallel to the front of computer) through the plotter light.

6. Draw a horizontal stop line parallel to the start line exactly 12 inches up from start line.

7. Turn the Ya handcrank to position the index light exactly on the stop line.

8. Read the Yp counter, and enter the value in column 3, top line.

Table 23

## TEST FOR INDEX-LIGHT TRAVEL

Column	1	2	3	4	5	6	7	8	9	10
Run	Xp Reading at Start	Xp Reading at Stop Calc	Xp Reading at Stop Inst	Error Inches	2F Start Calc Volts	2F Start Inst Volts	Error Volts	2F Stop Calc Volts	2F Stop Inst Volts	Error Volts
1	20.00	8.00			-0.588			+1.371		
	8.00	20.00			+1.371			-0.588		
		Allow	Error	0.04	Allow	Error	0.012	Allow	Error	0.012
Column	1	2	3	4	5	6	7	8	9	10
Run	Yp Reading at Start	Yp Reading at Stop Calc	Yp Reading at Stop Inst	Error Inches	3C Start Calc Volts	3C Start Inst Volts	Error Volts	3C Stop Calc Volts	3C Stop Inst Volts	Error Volts
2	2.00	14.00			-2.350			-0.392		
	14.00	2.00			-0.392			-2.350		
		Allow	Error	0.04	Allow	Error	0.012	Allow	Error	0.012

9. Read the TEST UNIT voltage, and enter the value in column 9, top line.

10. Enter the voltage reading of step 9 in column 6, bottom line.

11. With the Ya handcrank, return the index light to the start line.

12. Read the Yp counter, and enter the value in column 3, second line.

13. Read the TEST UNIT voltage, and enter the reading in column 9, second line.

14. Calculate the error in inches, and enter the results in the appropriate error columns.

## Section 5.3 —Trouble Shooting

Whenever test results exceed allowable limits, or the computer is not functioning properly, immediate steps should be taken to determine the cause. The possibility of human error, such as the incorrect reading of a dial, incorrect input settings, and similar causes, should be considered first. Once this possibility has been eliminated, the trouble-shooting information in this section should be used to find the cause of the malfunction.

After an examination of the test results, the appropriate procedures as outlined in this section may be used as a guide for locating and correcting the trouble. When the fault has been corrected, the basic cause of the error should be determined and eliminated to prevent recurrence of the same condition. Then the test or problem in which the error first was discovered should be run, followed by a complete set of the routine tests to determine if the computer is again in satisfactory condition.

## COMMON MECHANICAL AND ELECTRICAL FAULTS

The origin of excessive errors may be mechanical, electrical, or a combination of both.

Possible mechanical faults are:

Tight gear meshes

Loose gear meshes

Sticky shaft lines (caused by foreign particles in gear teeth or bearings)

Sheared taper pins or slipped clamps

Damaged gear teeth

Rusty bearings

Shaft hangers in misalignment

Rubbing or similar mechanical interference

Possible electrical faults are:

Faulty electron tubes

Excessive electrical pickup possibly due to improper grounding or shielding)

Short circuits

Open circuits

Blown fuses

Imperfect ground connections

Defective capacitors (open, grounded, or shorted)

Deteriorated resistors

Potentiometers (dirty or pitted contact surfaces)

Switches (dirty or pitted contact surfaces)

Relays (poor contact surfaces or faulty solenoids)

Failure of components within an electronic element

## COMPONENT IDENTIFICATION

## Element Designation Numbers

The designation system used in this book which identifies all components in Computer Mk 48 Mod 1 except standard hardware such as nuts, bolts, and washers, uses one or two capital letters followed by a four-digit number. Each designation identifies a particular element, such as a resistor, amplifier, or network box, and the designation is not duplicated, even though several identical elements are used in the computer.

The alphabetical symbols have the following meanings:

- A - Structural parts, panels, frames, etc
- B - All motors, resolvers, and synchro units
- C - Capacitors
- E - Miscellaneous electrical parts (terminal blocks, etc)
- F - Fuses
- G - Rate generators
- H - Mechanical components (adjustments, differentials, limit stops, integrators, clutches, etc)
- I - Indicators (neon lights)
- J - Jacks and receptacles
- K - Relays
- R - Resistors and potentiometers
- S - Switches, interlocks, and thermo regulators
- T - Transformers and chokes

V - Vacuum and gas-discharge tubes

W - Wires and cables

X - Sockets

CR - Selenium rectifiers

ZA - Amplifiers

ZB - Servo controls

ZC - Power-supply regulators

ZM - Miscellaneous electrical units

ZN - Resistance networks

ZY - Frequency standard for computing voltage

In a four-numbered designation, the first two numbers indicate the element unit number of the drawer assembly or the mechanical section in which the element is located. A legend plate on a panel, for example, may bear the element unit number "4100." Since the first two numbers are four and one, the elements housed in that section are of the 4100 series. The last two numbers of an element designation indicate that an element is one of a series of elements located in that section. Element unit number ZA4107 would indicate that the element is an amplifier located in the 4100 section, and is the seventh element of a series of elements located in that section.

Each element is marked plainly with its designation number. This same designation also is used to identify it on drawings, or whenever it is referred to in tests or adjustment procedures.

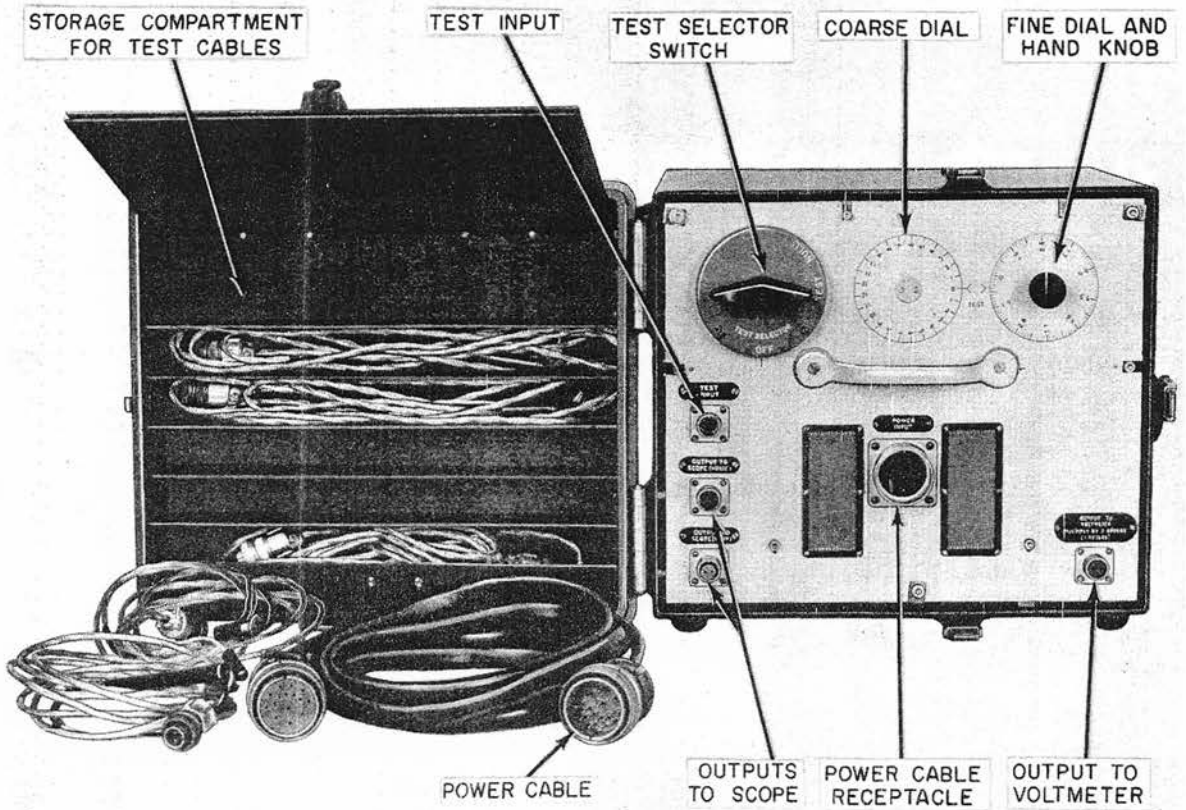

Figure 38. Test-Unit Operating Controls

### Manufacturer's Unit Designation Numbers

The manufacturer, in addition to the element unit-number designations, assigns a manufacturer's unit number to each element. The manufacturer's unit number should not be confused with an element's letter-number designation. The manufacturer's unit number will contain four numbers. The first two numbers of the designation identify the principal function of the element. The last two numbers indicate that it is one of a series. The unit number 3200, for example, is assigned to servo amplifiers. The unit number 3204, therefore, indicates that it is a servo amplifier and is the fourth element of a series of servo amplifiers.

The principal unit numbers encountered during normal maintenance of the computer are:

Unit Number	Element
3000	Amplifiers (except servo)
3100	Networks (summing or dividing type)
3200	Servo amplifiers
3300	Servo controls (except contact type)
3400	Frequency standards
3800	Rectifiers and power supplies

Computer elements that possess identical unit numbers may be interchanged readily. Therefore, when a replacement of an element is needed, determine what its unit number is from its schematic or from table 39, and select a new element that has the same unit number.

### Drawing Numbers

Another identification system that is used pertains to separate parts, such as shafts, hangers, etc, and to all assemblies and subassemblies (which include the elements referred to previously), and consists merely of either stamping or affixing a drawing number to each part or assembly. These two systems facilitate the procurement of replacement parts as well as simplifying the identification of individual components.

### TEST UNIT

The test unit, figure 38, that accompanies the computer is used to perform the trouble-shooting procedures outlined in this section. It functions as a proportional voltmeter, by comparing the voltage under test with the reference voltage from which it was derived. Essentially, the unit is a servo loop with a precision potentiometer in the feedback leg of the loop, figures 39 and 40. The servo action is stopped (nulled) and the test dials mechanically positioned as the output of this potentiometer equals (nulls) the test-input signal. The dials show the fractional part of the computer reference voltage existing at various selected intermediate points in the computing circuits.

In the trouble-shooting tests the specific circuit-point voltages to be measured with this instrument are listed in a column. The circuit point will be a number-letter combination followed by an asterisk, such as 3G\*. The same symbol will appear in the schematic adjacent to the point of measurement.

The test circuit points within the computer are connected electrically to the test-unit input cable through the SIGNAL TO TEST UNIT jack and SIGNAL TEST SELECTOR switch on the computer, figure 41. This switch is located in the rear, upper right-hand corner of the computer,

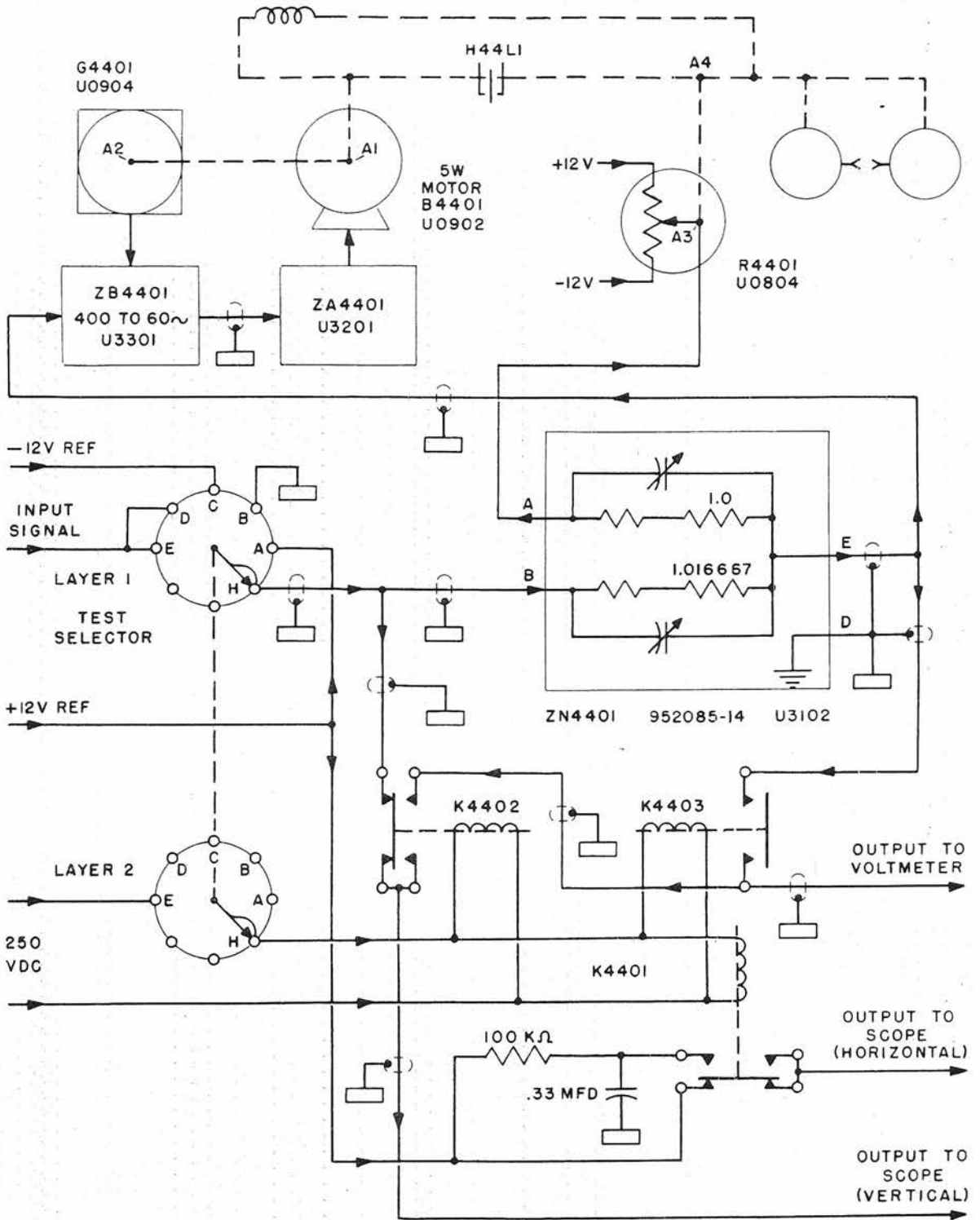

Figure 39. Test Unit, Schematic Diagram

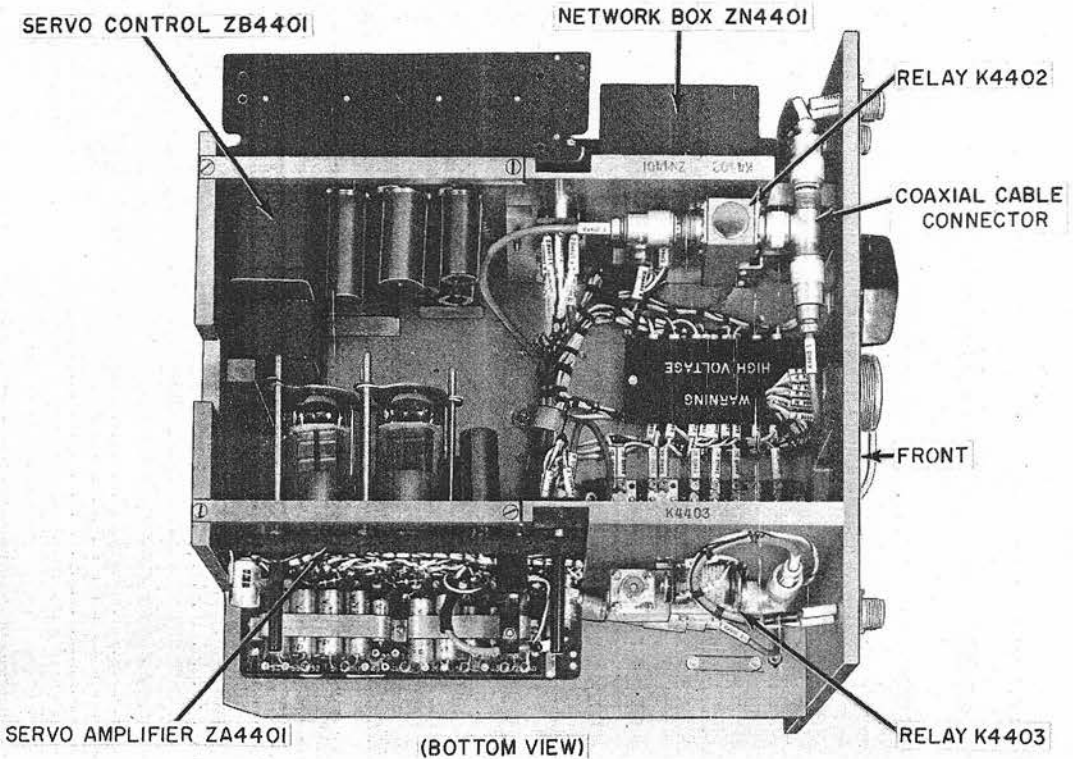
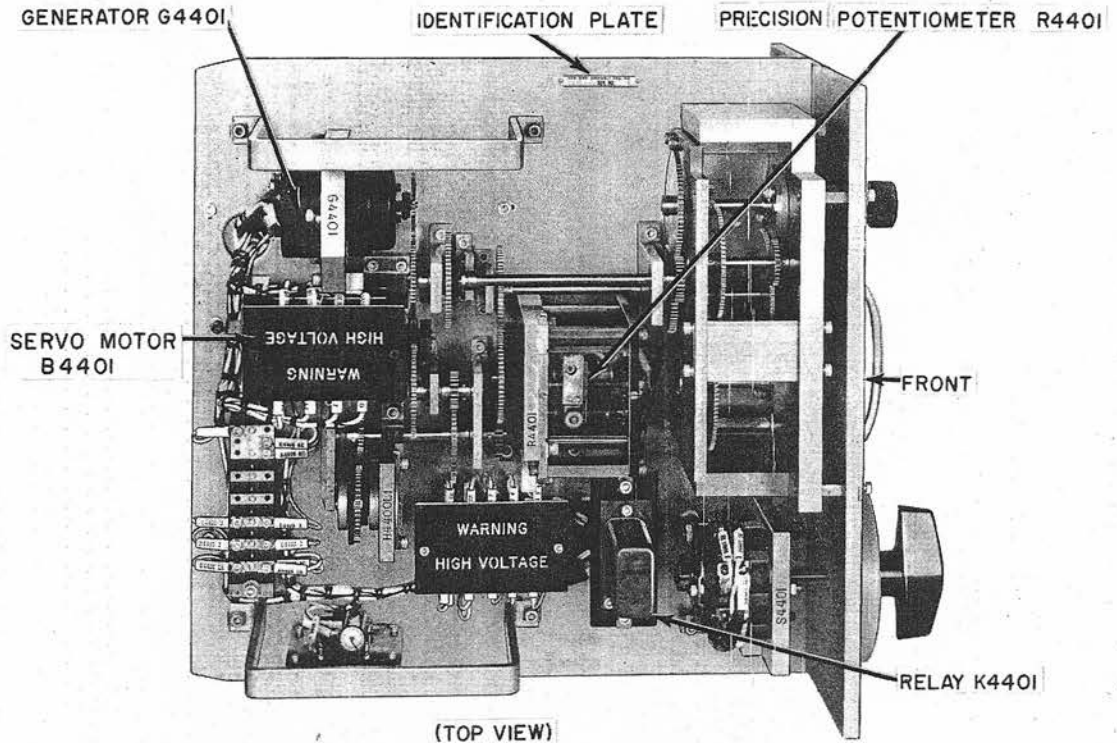

Figure 40. Test Unit Removed from Case

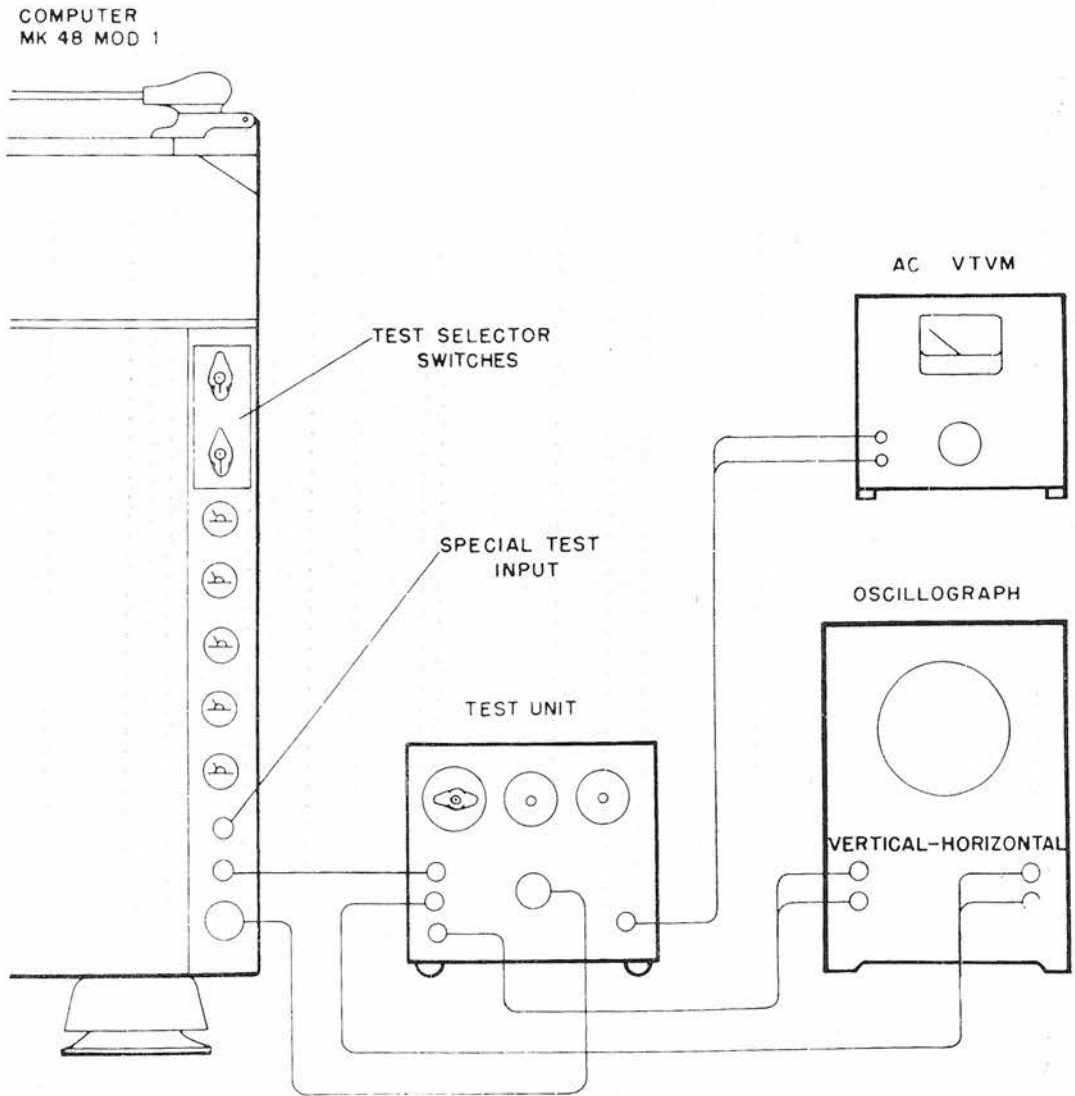

Figure 41. Test-Unit Connections to Computer Mk 48 Mod 1

immediately above the DC voltmeters. If, for example, the prescribed test requires the voltage at circuit point 3G\* to be measured, the SIGNAL TEST SELECTOR switch is set to read 3 on the number switch and G on the letter switch.

#### Reading and Interpretation of Test-Unit Dials

The coarse and fine dials of the test unit cover a range of 25 units - from -12.50 to +12.50. Red numerals are used for the negative values and black for the positive values. The fine dial has 100 graduations representing ten millivolts each. A reading, however, can be readily extended to three decimal places by estimating the fractional part between the significant graduation and the dial index mark.

The polarity or sign of the test voltage, as established by the position of the coarse dial, determines which numerals on the fine dial should be read. If, for example, a red number is observed on the coarse dial, the red numbers on the fine dial should be noted.

All values specified by the tests are expressed in terms of twelfths of the reference voltage. That is, with a nominal reference voltage of 12 volts, a reading of 12 would be 12 volts, and a reading of 8 would be 8 volts. However, if the reference voltage was only 9, a reading of 12 would be 9 volts (12/12 of 9 volts). Similarly, a reading of 8 would be 6 volts (8/12 of 9 volts). Although the intermediate test values sometimes are referred to as voltages, the test-unit dials do not necessarily indicate true voltage values but rather the computed proportion of the reference voltage that is independent of the actual reference voltage value. Any discrepancy in the reference voltage value would have to be determined by means of an independent AC meter.

#### Test-Unit Operating Procedure

The following procedure shall be used when measuring intermediate computed voltages with the test unit.

1. Open the compartment in the test-unit cover, and remove the large cable and one small cable (connectors at both ends).
2. Turn the TEST SELECTOR switch on the test unit to OFF.
3. Turn the SIGNAL TEST SELECTOR switch on the computer to OFF.
4. Connect the large cable from the POWER INPUT on the test unit to the computer receptacle designated TEST UNIT POWER SUPPLY.
5. Connect the small cable from the TEST INPUT on the test unit to the computer receptacle designated SIGNAL TO TEST UNIT.
6. Energize the computer.
7. Check the test unit for proper operation as follows:
  - a. Turn the TEST SELECTOR switch on the test unit to +12. The coarse dial should read +12 and the fine dial zero.
  - b. Turn the TEST SELECTOR switch on the test unit to OFF. Both dials should read zero.
  - c. Turn the TEST SELECTOR switch on the test unit to -12. The coarse dial should read -12 and the fine dial zero.
8. Turn the SIGNAL TEST SELECTOR switches on the computer to the combination prescribed for the particular test.

9. Turn the TEST SELECTOR switch on the test unit to TEST.

10. Read the measurements on the test-unit dials.

### Special Applications

When difficulty is experienced in determining the exact cause of faulty operation, it may be helpful to analyze the pertinent computing voltages through the use of special provisions on the test unit. These include connecting and switching facilities for an oscilloscope, an AC vacuum tube voltmeter, and a special test probe. When the test equipment is set up as shown in figure 41 additional information can be gained regarding the test-point voltage that is fed into the test unit via the computer test selector switches or through the special probe.

**Waveform Checks.** Electrical quantities to be viewed on the oscilloscope should be checked as follows: First, the waveform is displayed using the internal linear sweep of the scope. To accomplish this, turn the TEST SELECTOR switch of the test unit to TEST, and check the signal for excessive noise and distortion. Next, switch the scope horizontal input to EXTERNAL to connect in the +12 volt, 400-cycle reference from the test unit. Examine the pattern to determine the extent of phase shift.

This procedure may indicate the presence of excessive quadrature voltage; that is, the 90-degree component of an input signal that is out-of-phase with the reference source because of a circuit fault. For example, a voltage vector with a 20-degree phase shift would be represented as vector B shown in figure 42. The in-phase component of this vector, which is usable servo control voltage, is represented by vector C in the diagram. The quadrature component, vector A, has no controlling effect on the servo, but along

with the in-phase component, contributes toward saturation of the servo amplifier. The total amplifier output therefore contains a percentage of quadrature voltage to which the servo cannot respond. Since the full amplifier output is not usable control voltage, the servo takes on a loose response characteristic.

If the scope pattern and the action of the test-unit servo indicate the presence of quadrature voltage, the magnitude of this voltage may be determined as follows: The TEST SELECTOR switch is turned to NULL, transferring the oscillograph vertical input to the null of the test-unit servo loop, connecting the VTVM to the same point, and switching the horizontal input of the oscillograph through a 90-degree phase shift network. The knob on the test-unit fine dial then is used to manipulate the servo within the dead space to the extent necessary to shape the oscillograph pattern into a straight line. This will occur when the in-phase component of the signal voltage has been perfectly nulled, leaving only the 90-degree component present in the null. The null quadrature voltage then can be read on the AC VTVM.

**Test Probe for Random Measurements.** To extend the usefulness of the test unit a special probe is provided to measure signal voltages at points not covered by the SIGNAL TEST SELECTOR switch. For instance, after localizing trouble to a small group of elements through performance of the trouble-shooting tests, the signal then can be traced component-by-component or stage-by-stage between the regular test points until the trouble is pinpointed. Using a setup similar to that shown in figure 41, plug the special test probe into the SPECIAL (7E) TEST INPUT jack on the computer and connect it to the test unit by setting the SIGNAL TEST SELECTOR switch at 7-E. The probe then is ready for use following the general procedure previously described. Thus, the signal voltage at any point can be

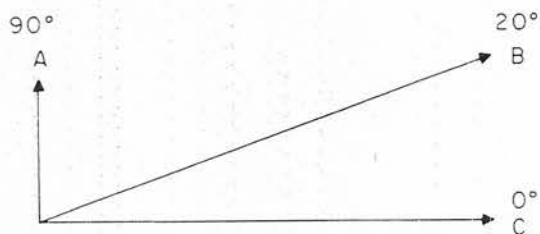

Figure 42. In-Phase and Quadrature Components of 20-Degree Voltage Vector

measured and examined for wave form, noise, and quadrature voltage.

SF at 50,000:1 Xa at 10,000 yards = +2.350 volts at 2G  
Xj at 0 yards Ya at 10,000 yards = +2.350 volts at 3D

### NEON MONITORING SYSTEM

The neon lights, figure 43, indicate the functional condition of the computing amplifiers, servo controls, and servo amplifiers. The computer also contains a provision for testing the individual neon lights. Each light is identified with the particular element or elements it monitors by element designation symbols above the light.

The first stage of each dual-channel amplifier is monitored continuously for proper minimum plate current. To check the computing amplifiers, observe the neon lights in group ZAC during operation of the computer. If a light glows steadily during operation, it indicates that the first stage of the corresponding amplifier is defective. Intermittent flashing of the computing amplifier neons usually is caused by transient conditions in computer operation and should be disregarded.

To check the second and third (output) stages of all dual-channel computing amplifiers (except ZA4329B and ZA4335A), set up the computer as follows:

B'r' at 45°	Yj at 0 yards
Co at 0°	DIRECTOR SELECTOR switch at MB
So at 0 knots	RADAR BEACON
R at 20,000 yards	DELAY spot switch at OFF
OL' at 25°	Connect test unit to computer for the following settings:
OZh at 25°	
Hs at 1000 feet	Xt at 20,000 yards = -4.700 volts at 3A
Ht at 5000 feet	Yt at 22,454 yards = -5.277 volts at 3E

With both test switches at the OPERATE position, all computing amplifier neon lights (group ZAC) should remain off.

To check all servo-control elements and the first stages of the four single-channel computing amplifiers (ZA4325, ZA4327, ZA4341, and ZA4342), hold the S.C.-S.A. switch in its up position, designated SERVO CONTROL TEST. If one of these elements is defective, its related neon light in group ZB or ZAC will glow.

To check all servo-amplifier elements and the second and third stages of the four single-channel computing amplifiers, hold the S.C.-S.A. switch in its down position, designated AMPLIFIER TEST. If any element is defective, its related neon light in group ZAS or ZAC will glow.

To check the neon lights of group ZB, hold both S.C.-S.A. and S.C. NEON-S.A. NEON switches in the up position, designated SERVO CONTROL TEST and SERVO CONTROL NEONS, respectively. All the ZB neon lights should glow.

To check all amplifier neon lights in group ZAS and ZAC, hold both S.C.-S.A. and S.C. NEON-S.A. NEON switches in the down position, designated AMPLIFIER TEST and AMPLIFIER NEONS, respectively. All ZAS and ZAC neon lights should glow.

In addition to the neon lights on the indicating panel, each element monitored is equipped with a similar neon bulb connected in series with the panel bulb. The bulb on the element chassis glows whenever the panel light glows, making it possible to visually locate a faulty element in either of the drawer baskets.

NEON MONITORING  
SYSTEM TEST  
SWITCHES (S.C.-S.A.)

DZUS FASTENERS

NEON MONITORING  
SYSTEM PANEL  
BOARD

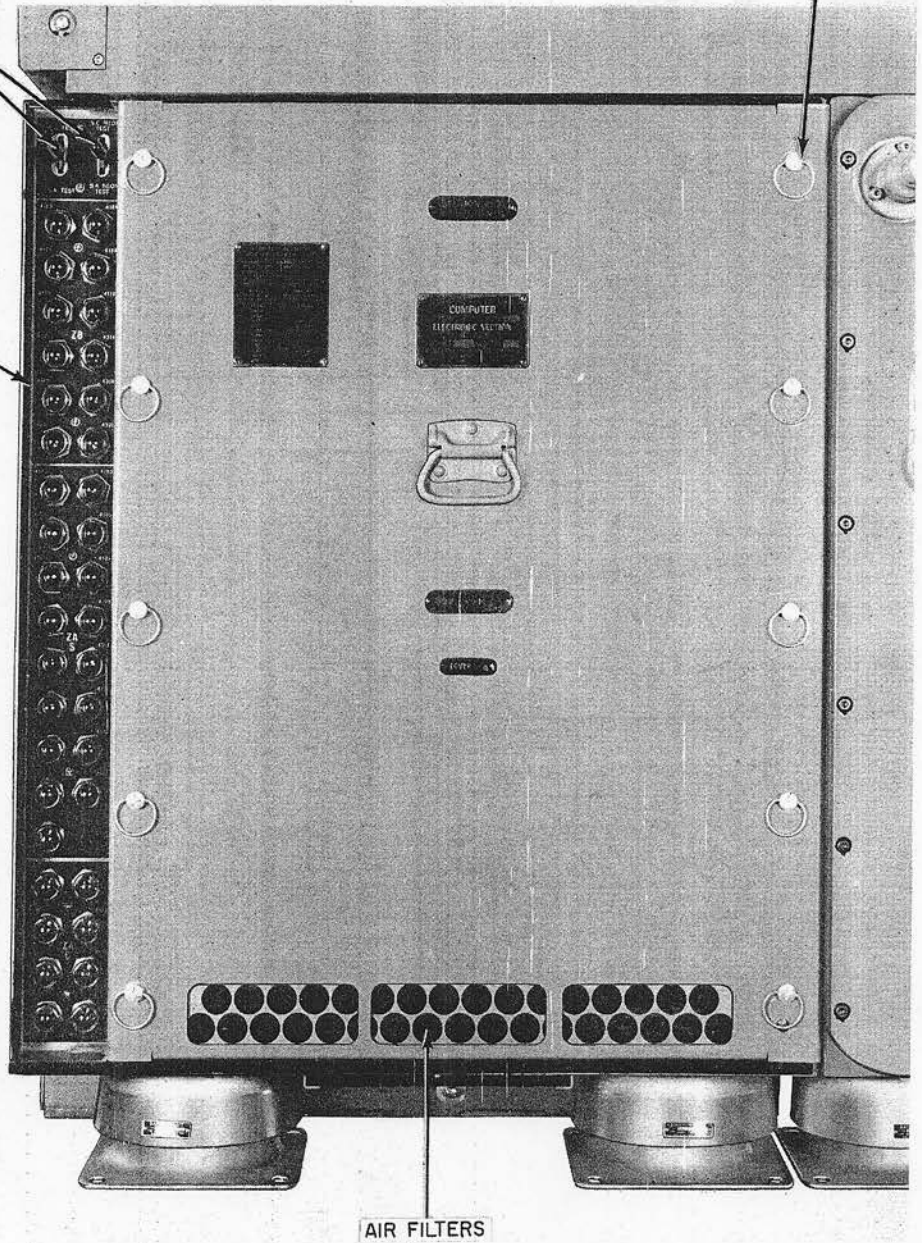

Figure 43. Computer Mk 48 Mod 1, Front Electronic Section

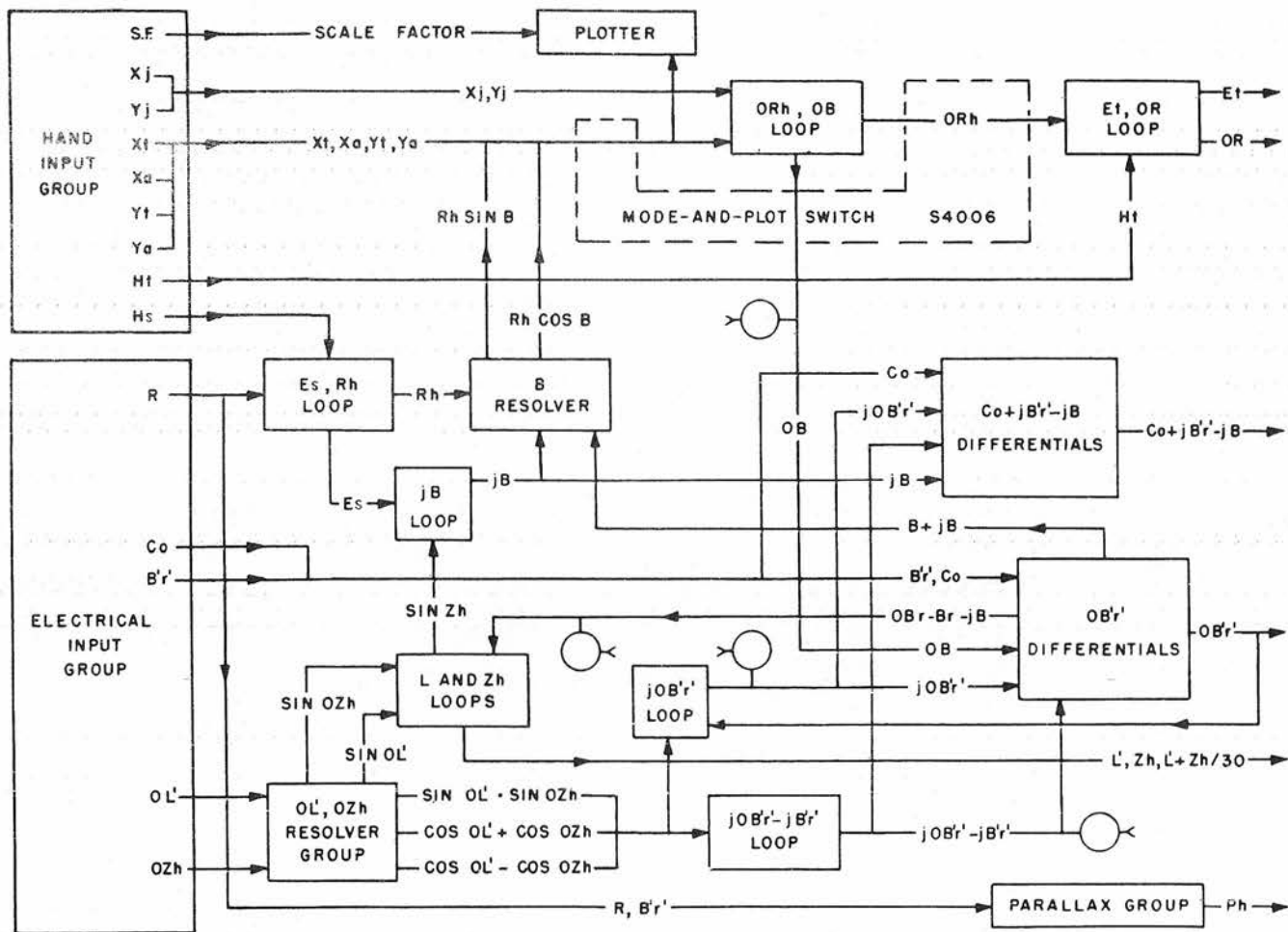

Figure 44. A-Test Trouble Shooting, Overall Block Schematic

## FUSES

The computer is protected from overloads by 13 fast-acting thermal-cutout cartridge fuses. All fuses are plainly visible, and are arranged on a panel at the rear of the computer. Each fuse is held in place and protected by a removable clear plastic cover. A blown fuse is indicated by the appearance of a red dot in the center of its plastic cover.

The fuse number designation next to each fuse identifies that particular fuse in accordance with the power-supply diagram, BuOrd Dwg 1371754. When replacing a fuse, check the rating stamped on the fuse cap against the rating specified in the power-supply diagram.

A compartment for six spare fuses is located in the fuse panel. To gain access to the spares unscrew the two cover screws one-half turn and remove the cover.

Table 24 is a general reference table for the fuses used in this computer.

## A-TEST ANALYSIS

Before performing any procedure for isolating the cause of an A-test error, the possibility of a faulty problem setup, a power-supply failure, a transmission failure, or a computing element casualty of the type traceable through the neon-indicator system first must be eliminated. The complete routine for preparing the computer for A tests should be rechecked as well as the entire set of independent variables for the test problem or problems in question. All power-supply meters should be checked for indication of correct voltage. Check switch positions and fuses on Computer Mk 48 Mod 1, the motor-generator set, the main switchboard, shore-bombardment auxiliary switchboard, gyro-compass, pitometer log, and all other associated equipment used in the test problem. Check all transmission circuits

directly involved in the A test by comparing the received values with the transmitted values. Finally, the routine neon-indicator test of electronic elements, as described under the previous heading, should be rerun for indication of newly developed casualties. Once the need for further trouble shooting has been ascertained, the steps suggested in the following procedure may be carried out.

1. Examine the A-test results, and list all outputs that have excessive errors.

2. Refer to figure 44 and table 25 to determine the blocks, or sections, of the computer that contribute to the computation of the quantity or quantities in error. Table 25 shows which groups of elements are common to various combinations of output quantities.

3. Refer to the detail functional schematics of the suspected groups (figures 47 through 59, and list the pertinent test points (intermediate voltages) and mechanical intermediate quantities.

4. Connect the test unit, and rerun the critical problems, that is, the problems that have the largest errors. Read and record all mechanical and electrical intermediate quantities selected in step 3.

5. Compare the intermediate quantity readings with those given in tables 26 and 27, and compute the errors.

6. From a study of the intermediate quantity errors and the pertinent detail schematics, determine in which element or group of elements the trouble originates.

7. Check each electronic element in the suspected group by substitution of spare units.

8. If the trouble persists, inspect the mechanical components of the affected group for the common faults listed at the beginning of this section.

Table 24

## FUSES

Fuse Designation	Current Rating (Amperes)	Protects
F4301	1	+250 v supply
F4302	1	+250 v supply
F4303	1	+250 v supply
F4304	1/10	-105 v supply
F4305	3	Line 1
F4306	5	Line 3
F4307	1	B'r' transmitter
F4308	1	OZh transmitter
F4309	1	OL' transmitter
F4310	1	R transmitter
F4311	1	Co transmitter
F4312	10	Line 2
F4313	15	+350 v supply (MG set)

## SPARES

Quantity	Current Rating (Amperes)
2	1
1	1/10
1	3
1	5
1	10

Table 25

A-TEST TROUBLESHOOTING

		Output in Error					
		OB'r'	Et or OR	Et, OR, OB'r'; and L', Zh, and L + Zh/30	Et, OR, OB'r'; Ph	L', Zh and L + Zh/30	Ph
Possible Source of Error	OB'r' differ-entials	Et and OR loop	ORh and OB loop Hand input group and mode switch	R input	L' and Zh loop	Parallax group	
	jOB'r' loop	ORh or Ht input	Plotter				
	jOB'r' -jB'r' loop		jB loop and B resolver				
	OL' and OZh resolver group		Es and Rh loop L' and Zh loops OL' and OZh resolver group				
	Electrical inputs		OB'r' differentials				

9. Check the mechanical limit stops in the affected group (see table 28). These checks cover the possibility of slippage in certain mechanical adjustments, as can be determined from the detail schematic. Also, run the pertinent trouble shooting test, tables 28 through 33, to obtain additional information for localizing the trouble.

10. Check each adjustment in the group, excluding limit stops checked in step 9, for conformance with the conditions specified in the adjustment procedure, section 5.5. The order given in the adjustment procedure should be followed and any adjustment not satisfying the requirements should be readjusted.

Special Trouble-Shooting Tests

If difficulty is experienced in localizing the trouble to a specific point, additional information can be obtained by running a special trouble-shooting test on the group of elements to which the trouble has been traced. The first of these is the test of operating limits, table 28. All limit stops in the group of elements selected for detailed analysis should be checked according to the data given in the table. In general practice, all limits should be checked after any repair or readjustment procedure. The rest of the special tests are performed in a manner similar to A tests, but are designed for greater convenience in trouble shooting by limiting their scope to smaller groups of computing

Table 26

## MECHANICAL INTERMEDIATE QUANTITIES FOR A TESTS

PROB	OB		OBR-BR-JB *		JOB <sup>R</sup>		JOB <sup>R</sup> - JB <sup>R</sup>		E <sub>B</sub> (2000=0)	X <sub>P</sub> (16.4=0)	Y <sub>P</sub> (16.4=0)	Ph**	
	DEG	MIN	DEG	MIN	DEG	MIN	DEG	MIN	MINUTES	INCHES	INCHES	DEG	MIN
1	69°	50'	10°	00'	359°	49'	359°	59'	2692	23.89	16.20	0°	44'
2	70°	11'	10°	00'	0°	15'	0°	04'	2692	23.96	16.44	0°	44'
3	224°	42'	40°	00'	0°	07'	0°	25'	2483	21.77	18.54	0°	33'
4	224°	09'	40°	00'	358°	43'	359°	34'	2483	21.02	19.92	0°	33'
5	146°	26'	300°	00'	0°	10'	358°	44'	2122	17.20	27.90	359°	51'
6	144°	35'	300°	00'	0°	51'	1°	16'	2122	17.75	27.92	359°	51'
7	340°	13'	70°	00'	359°	57'	359°	43'	2082	1.40	6.51	359°	48'
8	339°	53'	70°	00'	0°	09'	0°	16'	2082	1.40	6.74	359°	48'
9	155°	39'	350°	00'	0°	19'	359°	40'	2069	24.54	29.63	0°	00'
10	155°	00'	350°	00'	0°	21'	0°	21'	2069	24.72	29.52	0°	00'
11	255°	40'	5°	00'	0°	29'	359°	49'	2069	1.29	16.15	359°	47'
12	255°	19'	5°	00'	0°	30'	0°	10'	2069	1.32	16.22	359°	47'
13	272°	00'	352°	00'	0°	00'	0°	00'	2191	5.90	5.62	0°	02'
14	272°	00'	352°	00'	0°	00'	0°	00'	2191	5.90	5.62	0°	02'
15	194°	58'	0°	00'	359°	58'	0°	00'	2000	18.56	25.36	0°	00'
16	195°	04'	0°	00'	0°	04'	0°	00'	2000	18.56	25.24	0°	00'

Symbols are given for Main Battery operation.

\* This quantity becomes (OBr - Br) for antiaircraft operation.

\*\* This quantity, which is a transmitted quantity, is included because its dial cannot be read with covers on.

Table 27  
A-TEST ELECTRICAL INTERMEDIATE QUANTITIES

PROB NO	1A R4002 R	1B B4080-R4 Es	1C B4080-R2 Es	1D R4005 Hs	1E B4096-R4 B'R'	1F R4015 R	1G R4007 PH	2A B4099-R4 JB
1	+1.175	-0.235	+1.151	+ 7.074	- 7.713	+0.067	-0.723	-0.173
2	+1.175	-0.235	+1.151	+ 7.074	- 7.713	+0.067	-0.723	0.000
3	+2.374	-0.329	+2.327	+ 9.903	-11.591	+0.101	-0.542	-0.370
4	+2.374	-0.329	+2.327	+ 9.903	-11.591	+0.101	-0.542	0.000
5	+3.854	-0.133	+3.758	+ 4.008	+ 5.071	-0.044	+0.148	+0.071
6	+3.854	-0.133	+3.758	+ 4.008	+ 5.071	-0.044	+0.148	0.000
7	+3.337	-0.078	+3.289	+ 2.358	+ 6.000	-0.052	+0.201	-0.025
8	+3.337	-0.078	+3.289	+ 2.358	+ 6.000	-0.052	+0.201	0.000
9	+4.700	-0.094	+4.699	+ 2.829	0.000	0.000	0.000	-0.061
10	+4.700	-0.094	+4.699	+ 2.829	0.000	0.000	0.000	0.000
11	+5.875	-0.118	+5.874	+ 3.537	+11.276	-0.098	+0.211	-0.005
12	+5.875	-0.118	+5.874	+ 3.537	+11.276	-0.098	+0.211	0.000
13	+7.050	-0.392	+7.039	+11.789	- 2.084	+0.018	-0.032	0.000
14	+7.050	-0.392	+7.039	+11.789	- 2.084	+0.018	-0.032	0.000
15	—	—	—	—	- 8.485	+0.074	0.000	0.000
16	—	—	—	—	- 8.485	+0.074	0.000	0.000

Table 27 (Cont'd)  
A-TEST ELECTRICAL INTERMEDIATE QUANTITIES

PROB NO	2B R4018 Es	2C B4081-R2 B	2D B4081-R3 B	2E R4016 XJ	2G R4010 XA	3B R4017 YJ	3D R4011 YA	3F B4082-R3 OB
1	+0.258	-0.987	-0.593	0.000	-0.235	0.000	+0.590	+2.053
2	0.000	-0.999	-0.572	0.000	-0.235	0.000	+0.579	+2.061
3	+0.578	+0.119	+2.324	0.000	-0.470	0.000	-2.184	+2.842
4	0.000	+0.168	+2.321	0.000	-0.470	0.000	-2.091	+2.941
5	-0.110	+1.693	+3.355	-7.679	-1.880	-2.194	-0.652	+3.187
6	0.000	+1.563	+3.417	-7.679	-1.880	-2.194	-0.710	+3.263
7	+0.039	+3.289	-0.006	-0.549	+0.235	-1.646	-2.318	+3.157
8	0.000	+3.289	+0.007	-0.549	+0.235	-1.646	-2.277	+3.106
9	+0.096	-1.187	+4.547	+5.485	-0.151	-8.776	-2.387	+2.937
10	0.000	-1.216	+4.539	+5.485	-0.151	-8.776	-2.398	+2.933
11	+0.008	+5.542	+1.948	-8.228	+0.376	+2.743	-2.044	+4.592
12	0.000	+5.531	+1.978	-8.228	+0.376	+2.743	-2.049	+4.588
13	0.000	+6.932	-1.222	+4.388	-4.465	+7.679	-1.311	+7.266
14	0.000	+6.932	-1.222	+4.388	-4.465	+7.679	-1.311	+7.266
15	0.000	—	—	0.000	-0.141	0.000	+0.585	+1.092
16	0.000	—	—	0.000	-0.141	0.000	+0.577	+1.084

CONFIDENTIAL

OP 2074

CONFIDENTIAL

Table 27 (Cont'd)

## A-TEST ELECTRICAL INTERMEDIATE QUANTITIES

PROB NO	3G B4082-R2 0B	4A R4006 Ht	4B B4095-R2 Et	4C B4095-R3 Et	4D R4008 OR	4F R101 YP	4E R100 XP	4G R4001 S F
1	0.000	+ 5.895	0.000	-2.062	+2.061	+0.002	+0.650	+3.000
2	0.000	+ 5.895	0.000	-2.070	+2.069	-0.003	+0.656	+3.000
3	0.000	+ 2.358	0.000	-2.843	+2.841	-0.074	+0.186	+1.200
4	0.000	+ 2.358	0.000	-2.942	+2.940	-0.122	+0.160	+1.200
5	0.000	+ 3.301	0.000	-3.188	+3.187	-1.438	+0.100	+4.320
6	0.000	+ 3.301	0.000	-3.265	+3.264	-1.440	+0.169	+4.320
7	0.000	+ 0.707	0.000	-3.157	+3.155	+1.236	-1.875	+4.320
8	0.000	+ 0.707	0.000	-3.106	+3.104	+1.208	-1.875	+4.320
9	0.000	0.000	0.000	-2.937	+2.936	-1.148	+0.707	+3.000
10	0.000	0.000	0.000	-2.933	+2.932	-1.139	+0.722	+3.000
11	0.000	+ 2.122	0.000	-4.592	+4.590	+0.051	-3.148	+7.200
12	0.000	+ 2.122	0.000	-4.589	+4.586	+0.038	-3.142	+7.200
13	0.000	+11.082	0.000	-7.275	+7.271	+1.347	-1.312	+4.320
14	0.000	+11.082	0.000	-7.275	+7.271	+1.347	-1.312	+4.320
15	0.000	+ 0.707	0.000	-1.092	+1.092	-0.311	+0.075	+1.200
16	0.000	+ 0.707	0.000	-1.085	+1.084	-0.307	+0.075	+1.200

Table 27 (Cont'd)  
A-TEST ELECTRICAL INTERMEDIATE QUANTITIES

PROB NO	5A B4083-R1 OL'	5B B4083-R2 OL'	5C B4084-R1 OZH	5D B4084-R3 OZH	5E B4084-R2 OZH	5F B4086-R2 (2OB'R'+ JOB'R')	5G B4093-R2 (JOB'R'- JB'R')	6A B4088-R2 JOB'R'
1	+11.954	+1.046	+5.977	-5.977	+1.046	0.000	+0.003	+0.038
2	+11.954	+1.046	+5.977	-5.977	+1.046	0.000	+0.014	-0.054
3	+11.818	-2.084	+5.942	-5.942	+1.670	-0.199	-0.087	-0.026
4	+11.818	-2.084	+5.942	-5.942	+1.670	-0.200	-0.089	+0.264
5	+11.984	-0.628	+5.822	-5.822	-2.903	+0.299	+0.262	-0.035
6	+11.984	-0.628	+5.822	-5.822	-2.903	+0.197	+0.261	-0.176
7	+11.934	-1.254	+5.996	-5.996	-0.419	-0.082	+0.057	+0.012
8	+11.934	-1.254	+5.996	-5.996	-0.419	-0.078	+0.057	-0.033
9	+12.000	0.000	+5.796	-5.796	+3.106	+0.533	+0.069	-0.066
10	+12.000	0.000	+5.796	-5.796	+3.106	+0.569	+0.071	-0.071
11	+11.591	-3.106	+6.000	-6.000	0.000	+0.797	+0.036	-0.100
12	+11.591	-3.106	+6.000	-6.000	0.000	+0.814	+0.035	-0.102
13	+12.000	-0.000	+6.000	-6.000	0.000	0.000	0.000	0.000
14	+12.000	0.000	+6.000	-6.000	0.000	0.000	0.000	0.000
15	+11.984	+0.628	+5.996	-5.996	+0.419	+0.037	0.000	+0.006
16	+11.984	+0.628	+5.996	-5.996	+0.419	+0.037	0.000	-0.015

Table 27 (Cont'd)  
A-TEST ELECTRICAL INTERMEDIATE QUANTITIES

PROB NO	6B B4090-R4 (20BR-BR- JB)	6C B4085-R2 OZM	6D B4091-R1 (20BR-BR- JB)	6E B4094-R3 (JOB'R- JB'R)	6F B4087-R3 (20B'R'+ JOB'R')	6G B4089-R3 JOB'R'	7A B4092-R3 (OBR-BR- JB)	7B B4092-R4 (OBR-BR- JB)
1	0.000	+0.182	+0.343	-0.365	+0.062	-0.365	-2.423	-1.697
2	0.000	+0.182	+0.343	-0.365	+0.064	+0.365	-2.423	-1.697
3	-0.257	-0.580	-0.210	+1.160	-0.757	+1.160	+1.046	-5.237
4	-0.258	-0.580	-0.193	+1.160	-0.752	-1.160	+1.046	-5.237
5	-1.193	+0.304	-0.292	-0.608	+0.593	-0.608	-4.400	+3.991
6	-1.163	+0.304	-0.315	-0.608	+0.601	+0.608	-4.400	+3.991
7	-0.149	+0.088	-0.135	-0.175	+0.164	-0.175	+1.645	-2.071
8	-0.151	+0.088	-0.134	-0.175	+0.165	+0.175	+1.645	-2.071
9	-0.550	0.000	0.000	0.000	0.000	0.000	+1.079	-6.117
10	-0.569	0.000	0.000	0.000	0.000	0.000	+1.079	-6.117
11	-0.289	0.000	0.000	0.000	0.000	0.000	+6.188	-0.542
12	-0.279	0.000	0.000	0.000	0.000	0.000	+6.188	-0.542
13	0.000	0.000	0.000	0.000	0.000	0.000	0.000	0.000
14	0.000	0.000	0.000	0.000	0.000	0.000	0.000	0.000
15	0.000	+0.044	+0.088	+0.088	0.000	-0.088	-1.256	-0.838
16	0.000	+0.044	+0.088	+0.088	0.000	+0.088	-1.256	-0.838

Table 27 (Cont'd)  
A-TEST ELECTRICAL INTERMEDIATE QUANTITIES

PROB NO	7C B4098-R4 Zm	7D B4097-R4 L'	7F B4081-R2 B	7G B4081-R3 B	PROB NO	7C B4098-R4 Zm	7D B4097-R4 L'	7F B4081-R2 B	7G B4081-R3 B
1	+0.848	+1.211	-0.987	-0.593	9	+3.059	-0.539	-1.187	+4.547
2	+0.848	+1.211	-0.999	-0.572	10	+3.059	-0.539	-1.216	+4.539
3	+2.619	-0.523	+0.119	+2.324	11	+0.271	-3.094	+5.542	+1.948
4	+2.619	-0.523	+0.168	+2.321	12	+0.271	-3.094	+5.531	+1.978
5	-1.995	+2.200	+1.693	+3.355	13	0.000	0.000	+6.932	-1.222
6	-1.995	+2.200	+1.563	+3.417	14	0.000	0.000	+6.932	-1.222
7	+1.035	-0.823	+3.289	-0.006	15	+0.419	+0.628	—	—
8	+1.035	-0.823	+3.289	+0.007	16	+0.419	+0.628	—	—

Table 28

## TEST OF OPERATING LIMITS

Limit Stop	Function	Location	Range	Reading on Dial or Counter	
				Lower Limit	Upper Limit
H40L1	Yp	U1204	±16.4 in	0	32.8
H40L2	Xp	U1204	±16.4 in	32.8	0
H40L3	Xj	U4004	±1000 yds	-1000	+1000
H40L4	Et	U1403	0 to 20°	2000	3200
H40L5	Hs	U4004	0 to 5000 ft	0	5000
H40L6	Ht	U4004	0 to 5000 ft	0	5000
H40L7	Es	U1202	0 to 30°	2000	3800
H40L8	OR	U1402	500 to 50,000 yds	500	50,000
H40L9	Yj	U4004	±1000 yds	-1000	+1000
H40L10	L' or L	U1404	±25°	* -5.071	+5.071 at 7D
H40L11	Zh or Zd**	U1404	±25°	* -5.071	+5.071 at 7C
H40L12	OL' or OL	U1301	±25°	* -5.071	+5.071 at 5B
H40L13	OZh or OZd	U1304	±25°	* -5.071	+5.071 at 5E
H40L14	jOB'r' -jB'r'	U4005	±20°	-20	+20
H40L15	jOB'r'	U4005	±20°	-20	+20
H40L16	jB***	U1201	±15°	* +3.106	-3.106 at 2A
H40L17	Ph	U1405	±12°	-12	+12
H40L18	So	U4004	0 to 55 knots	0	55

\*Voltages to be read at indicated voltage check points.

\*\*Remove potentiometer R4018 when checking limit stop.

\*\*\*Remove ZN4304 when checking limit stop.

Table 28 (Cont'd)

## TEST OF OPERATING LIMITS

Limit Stop	Function	Location	Range	Reading on Dial or Counter	
				Lower Limit	Upper Limit
H40L19	R	U4004	500 to 50,000 yds	500	50,000
H40L20	S. F.	U4009	10,000 to 100,000:1	10,000	100,000

elements. Thus, a suspected group of elements may be examined by using simplified problem setups.

The special trouble-shooting tests are presented in tabular form, with columns of figures for the input settings, intermediate quantities, and final problem results. Wherever an input "setting" column heading includes the word "volts," the values given must be indicated by means of the test unit. This is done by setting the SIGNAL TEST SELECTOR switch at the test-point symbol given in the column heading below the input function symbol. Column headings for the intermediate check voltages, which must also be indicated on the test-unit dials, contain the test-point symbol, the element identification number with the terminal number being tested, and the symbol of the principal quantity involved in the computation at that point. Reference to the appropriate schematic, figures 47 through 59, will show the complete designation of the function at each test point.

The special tests are:

Deck-tilt test

Deck-tilt resolver check

Es computation test

Et or OR computation test

Xp or Yp computation test

Ph computation test

**Deck-Tilt-Correction Test.** This test statically checks the computing accuracy of the elements in the OB computing loop, figure 52, the OL' and OZh resolver group, figure 54, the jOB'r - jB'r' loop, figure 56, the jOB'r' loop, figure 57, and in the L' and Zh loops, figure 55. Only seven inputs must be varied, four of which are the reference and target coordinates needed to provide the required OB input for the deck-tilt-corrector elements. The deck-tilt test is given in two tables: table 29 for the main-battery computation; and table 30 for the antiaircraft battery computation.

The mechanical outputs to be read and recorded are the transmitted quantity OB'r' and the loop outputs jOB'r' and jOB'r' - jB'r'. Through the use of the

Table 29

## TEST FOR DECK TILT CORRECTION COMPUTATION (MB)

## Settings

OL' Min 2000 = 0	OZh Min 2000 0	B'r' Deg Min	Xa* 2F Read	Ya* 3C Read	Xt* 3A Read	Yt* 3E Read
2000	3200	0°00'	+1.175	+1.175	-2.350	-1.250
3200	2000	0°00'	+1.175	+1.175	-2.350	-1.104
3200	3200	0°00'	+1.175	+1.175	-2.350	-1.165
1400	1400	15°00'	+1.175	+1.175	-2.350	-0.415
800	800	15°00'	+1.175	+1.175	-2.350	-0.341
2000	800	45°00'	+1.175	+1.175	+0.000	-1.763

\*Rotate Xa, Ya, Xt, Yt handcranks to give desired readings at respective voltage checkpoints. Refine with handcranks so that (OBr - Br - jB) dial reads 45 degrees for problems 1, 2 and 3; 60 degrees for problems 4 and 5; and 300 degrees for for problem 6.

## Settings

5A B4083-R1 OL'	5B B4083-R2 OL'	5C B4084-R1 OZh	5D B4084-R3 OZh	5E R4084-R2 OZh
+12.000	0.000	+5.638	-5.638	+4.104
+11.276	+4.104	+6.000	-6.000	0.000
+11.276	+4.104	+5.638	-5.638	+4.104
+11.818	-2.084	+5.909	-5.909	-2.084
+11.276	+4.104	+5.638	-5.638	-4.104
+12.000	0.000	+5.638	-5.638	-4.104

Table 29 (Cont'd)

## TEST FOR DECK-TILT-CORRECTION COMPUTATION (MB)

## Check Voltages

6C B4085-R2 OZh	6F B4087-R3 (2 OB'r' + jOB'r')	5F B4086-R2 (2 OB'r' + jOB'r')	6G B4089-R3 jOB'r'
0.000	0.000	-2.882	0.000
0.000	0.000	+2.882	0.000
+2.807	+0.428	0.000	-5.606
+0.724	+1.285	0.000	-1.447
+2.807	+4.832	0.000	-5.615
0.000	0.000	-2.890	0.000

## Check Voltages

6A B4088-R2 jOB'r'	6B B4090-R4 2(OBr - Br - jB) -(jOB'r' -jB'r')	6D B4091-R1 2(OBr - Br - jB) -(jOB'r' -jB'r')	6E B4094-R3 (jOB'r' - jB'r')
+0.360	+2.893	0.000	0.000
-0.360	-2.893	0.000	0.000
+0.642	0.000	-0.372	-5.603
+0.020	0.000	-0.753	-1.447
+0.038	0.000	-3.271	-5.588
-0.159	-2.546	0.000	0.000

Table 29 (Cont'd)

## TEST FOR DECK-TILT-CORRECTION COMPUTATION (MB)

## Check Voltages

5G B4093-R2 (jOB'r' -jB'r')	2A B4099-R4 jB	7A B4092-R3 (OBr - Br - jB)	7B B4092-R4 (OBr - Br - jB)
-0.362	0.000	-5.804	-5.804
+0.362	0.000	-5.804	+5.804
+0.747	0.000	-11.609	0.000
+0.275	0.000	+5.693	-1.525
+1.107	0.000	+11.213	-3.005
+0.318	0.000	-7.109	+4.104

## Check Voltages

7C B4098-R4 Zh	7D B4097-R4 L'
+2.902	+2.902
-2.902	+2.902
0.000	+5.804
+0.763	-2.846
+1.502	-5.606
-2.052	+3.554

Table 29 (Cont'd)

TEST FOR DECK-TILT-CORRECTION COMPUTATION (MB)

Results

Calc Deg Min	OB'r' Reading Deg Min	Error Min	Calc Deg Min	jOB'r' Reading Deg Min	Error Min
43° 13'			358° 14'		
46° 47'			1° 46'		
48° 48'			356° 42'		
76° 20'			359° 54'		
80° 38'			359° 49'		
346° 34'			0° 47'		
Total	Allow		Total	Allow	
Average			Average		
Maximum			Maximum		

Results

Calc Deg Min	(jOB'r' - jB'r') Reading Deg Min	Error
1° 47'		
358° 13'		
356° 12'		
358° 40'		
354° 22'		
358° 26'		
Total	Allow	
Average		
Maximum		

Table 30

## TEST FOR DECK-TILT-CORRECTION COMPUTATION (AA)

## Settings

OL Min 2000 = 0	OZd Min 2000 = 0	B'r Deg Min	Xa* 2F Read	Ya* 3C Read	Xt* 3A Read	Yt* 3E Read
2000	3200	0°00'	+1.175	+1.175	-2.350	-1.175
3200	2000	0°00'	+1.175	+1.175	-2.350	-1.175
3200	3200	0°00'	+1.175	+1.175	-2.350	-1.175
1400	1400	15°00'	+1.175	+1.175	-2.350	-0.431
800	800	15°00'	+1.175	+1.175	-2.350	-0.411
2000	800	45°00'	+1.175	+1.175	0.000	-1.601

\*Rotate Xa, Ya, Xt, Yt handcranks to give desired readings at respective voltage checkpoints. Refine with handcranks so that (OBr - Br - jB) dial reads 45 degrees for problems 1, 2 and 3; 60 degrees for problems 4 and 5; and 300 degrees for problem 6.

## Check Voltages

5A B4083-R1 OL	5B B4083-R2 OL	5C B4084-R1 OZd	5D B4084-R3 OZd	5E B4084-R2 OZd
+12.000	0.000	+5.638	-5.638	+4.104
+11.276	+4.104	+6.000	-6.000	0.000
+11.276	+4.104	+5.638	-5.638	+4.104
+11.818	-2.084	+5.909	-5.909	-2.084
+11.276	-4.104	+5.638	-5.638	-4.104
+12.000	0.000	+5.638	-5.638	-4.104

Table 30 (Cont'd)

## TEST FOR DECK-TILT-CORRECTION COMPUTATION (AA)

## Check Voltages

6C B4085-R2 OZd	6F B4087-R3 (2 OB'r +jOB'r)	5F B4086-R2 (2 OB'r +jOB'r)	6G B4089-R1 jOB'r
0.000	0.000	-2.893	0.000
0.000	0.000	+2.893	0.000
+2.807	-0.328	0.000	+5.605
+0.724	+1.241	0.000	+1.447
+2.807	+4.677	0.000	+5.579
0.000	0.000	+1.538	0.000

## Check Voltages

6A B4088-R2 jOB'r	6B B4090-R4 2(OBr - Br) -(jOB'r -jB'r)	6D B4091-R1 2(OBr - Br) -(jOB'r -jB'r)	6E B4094-R3 (jOB'r -jB'r)
+0.362	+2.893	0.000	0.000
-0.362	-2.893	0.000	0.000
-0.660	0.000	+0.328	-5.605
-0.336	0.000	-0.695	-1.447
-1.282	0.000	-2.637	-5.593
-0.192	-2.467	0.000	0.000

Table 30 (Cont'd)

## TEST FOR DECK-TILT-CORRECTION COMPUTATION (AA)

## Check Voltages

5G B4093-R4 (jOB'r -jB'r)	2A B4099-R4 jB	7A B4092-R3 (OBr - Br)	7B B4092-R4 (OBr - Br)
-0.362	0.000	-5.804	-5.804
+0.362	0.000	-5.804	+5.804
+0.660	0.000	-11.608	0.000
+0.267	0.000	+5.693	-1.525
+0.995	0.000	+11.213	-3.005
+0.309	0.000	-7.109	+4.104

## Check Voltages

7C B4098-R4 Zd	7D B4097-R4 L
+2.902	+2.902
-2.902	+2.902
0.000	+5.804
+0.763	-2.846
+1.502	-5.606
-2.052	+3.554

Table 30 (Cont'd)

TEST FOR DECK-TILT-CORRECTION COMPUTATION (AA)

Results

Calc Deg Min	OB'r Reading Deg Min	Error Min	Calc Deg Min	jOB'r Reading Deg Min	Error Min
46°47'			358°13'		
43°08'			1°47'		
41°39'			3°21'		
73°42'			1°38'		
69°56'			6°32'		
343°29'			0°57'		
Total	Allow		Total	Allow	
Average			Average		
Maximum			Maximum		

Results

Calc Deg Min	(jOB'r - jB'r) Reading Deg Min	Error Min
358°13'		
1°47'		
3°21'		
1°18'		
5°04'		
1°31'		
Total	Allow	
Average		
Maximum		

test unit and the computer SIGNAL TEST SELECTOR switch, 19 intermediate check voltages are made available for localizing the source of trouble.

The following list gives the steps necessary for performing the deck-tilt test either for MB or AA computation. In addition to the steps listed, the computer DIRECTOR SELECTOR switch must be positioned appropriately as shown in the table titles. The procedure is:

1. Connect the test unit to the computer.
2. Remove cover No. 6 for visual access to the jOB'r' and jOB'r' - jB'r' dials.
3. Energize the computer as for operation but leave time motor turned off.
4. Set and hold Co, Hs, Xj, Yj, So, and Hs at zero.
5. Set R at 5000 yards.
6. Set mode-and-plot switch at SHORE BOMB SHIP.
7. Transmit values of OL' and OZh given in the first two columns of table 29 from the stable vertical.
8. Manually set in values of B'r' given in third column.
9. Using the REF SHIP and TARGET coordinate handcranks, the voltage values shown for Xa, Ya, Xt, and Yt are set up on the test-unit dials with the SIGNAL TEST SELECTOR switch at the positions designated in the respective column headings.
10. Read and record the check voltages and the mechanically indicated problem results.

Deck-Tilt Resolver Check. In this procedure, each resolver in the jOB'r' and jOB'r' - jB'r' loops is checked separately for function, polarity, and adjustment. Where trouble-shooting procedure has indicated a faulty resolver in one of the two loops, perform the appropriate portion of the deck-tilt resolver check to verify the diagnosis. Part 1 checks the resolvers that compute the terms of the equation used in solving for jOB'r' - jB'r', as shown in figure 56. Similarly, Part 2 covers the jOB'r' loop shown in figure 57. The loop equation is included with each part of the test to identify the terms with the resolvers computing them.

NOTE: In the deck-tilt resolver check, the word "increase" or "increasing" means a change in the positive direction, that is, positive values become larger or negative values become smaller. Likewise, "decrease" or "decreasing" means a change in the negative direction; positive values become smaller or negative values become larger.

The procedure is:

1. Remove cover No. 6, and disconnect the line phase of the (jOB'r' - jB'r') and jOB'r' motors.
2. Connect the test unit to Computer Mk 48 Mod 1.
3. Energize the computer as for operation but leave the time motor turned off.
4. Control OL' and OZh from the stable vertical.
5. Control OB - B through the Co handcrank.
6. Control OB'r' through the B'r' handcrank.

7. Control  $(jOB'r' - jB'r')$  and  $jOB'r'$  at the respective servo motors.

9. Set the SIGNAL TEST SELECTOR switches at the combination indicated for each check.

8. Set the DIRECTOR SELECTOR switch at MB, except as indicated.

10. Observe output indications on test-unit dials.

## PART 1

 $jOB'r' - jB'r'$  Loop

Term	Resolver	Test Point
$-\left[\sin(jOB'r' - jB'r')\right](\cos OZh + \cos OL')$	B4093	*5G
$+\left\{\sin\left[2(OBr - Br) - (jOB'r' - jB'r')\right]\right\}(\cos OL' - \cos OZh)$	B4090	*6B
$+\left\{\cos\left[2(OBr - Br) - (jOB'r' - jB'r')\right]\right\}\sin OZh \sin OL'$	B4091	*6D
$-\left[\cos(jOB'r' - jB'r')\right]\sin OZh \sin OL' = 0$	B4094	*6E

## Resolver B4093 \*5G

- Increasing  $(jOB'r' - jB'r')$  makes the output decrease.
- Set  $(jOB'r' - jB'r' = 345$  degrees. The output should be positive for any combination of OZh and OL' and maximum (+3.491 volts) when OZh and OL' = 0.
- The sign of output should reverse when DIRECTOR SELECTOR switch is thrown to AA.

## Resolver B4090 \*6B

- When  $OL' = \pm OZh$ , output = 0
- Set  $OZh = 0$ ,  $OL' = -20$  degrees (800 min),  $(OB - B) = 0$ ,  $(jOB'r' - jB'r') = 0$ . The output should be 0. The output should decrease as  $(OB - B)$  is increased, and increase as  $(OB - B)$  is decreased. Output should increase as  $(jOB'r' - jB'r')$  is increased, and decrease as  $(jOB'r' - jB'r')$  is decreased.

\* SIGNAL TEST SELECTOR switch position.

## PART 1 (Cont'd)

## jOB'r' - jB'r' Loop

## Resolver B4091 \*6D

- a. When OL' or OZh = 0, the output = 0
- b. Set OZh = 3200 min, OL' = 800 min, (jOB'r' - jB'r') = 0  
 With (OB - B) = 0 degrees, the output = maximum negative value (-2.729 volts).  
 With (OB - B) = 45 degrees, the output = 0  
 With (OB - B) = 90 degrees, the output should be at maximum positive value (+2.729 volts)  
 With (OB - B) = 45 degrees, the output decreases as (jOB'r' - jB'r') is increased, and increases as (jOB'r' - jB'r') is decreased.

## Resolver B4094 \*6E

- a. When OL' or OZh = 0, the output = 0.
- b. Set OZh = 3200 min, OL' = 800 min, (jOB'r' - jB'r') = 0.  
 The output should be at maximum value (+2.729 volts).  
 The output to decrease when (jOB'r' - jB'r') is moved either way from zero.

## PART 2

## jOB'r' Loop

Term	Resolver	Test Point
- sin jOB'r' (cos OZh + cos OL')	B4088	*6A
- sin(2 OB'r' + jOB'r') (cos OL' - cos OZh)	B4086	*5F
- cos(2 OB'r' + jOB'r') sin OZh sin OL'	B4087	*6F
- cos jOB'r' sin OL' sin OZh = 0	B4089	*6G

## Resolver B4088 \*6A

- a. Increasing jOB'r' makes the output decrease.
- b. Set jOB'r' = -15 degrees (1100 min). The output should be positive for any combination of OZh and OL', and should be at maximum value (+3.419 volts) when OZh and OL' = 0.

\* SIGNAL TEST SELECTOR switch position.

## PART 2 (Cont'd)

## jOB'r' Loop

## Resolver B4086 \*5F

- a. When  $OL' = \pm OZh$ , the output = 0
- b. Set  $OZh = 0$  (2000 min),  $OL' = -20$  degrees (800 min),  $OB'r' = 0$ ,  $jOB'r' = 0$ : the output should be 0. The output should increase as  $OB'r'$  or  $jOB'r'$  is increased and decrease as  $OB'r'$  or  $jOB'r'$  is decreased.

## Resolver B4087 \*6F

- a. When  $OL'$  and  $OZh = 0$ , the output = 0
- b. Set  $OZh = 3200$  min,  $OL' = 800$  min,  $jOB'r' = 0$ .  
 With  $OB'r' = 0$  degrees, the output should be at maximum positive value (+2.729 volts)  
 With  $OB'r' = 45$  degrees, the output = 0  
 With  $OB'r' = 90$  degrees, the output = maximum negative value (-2.729 volts).
- c. With  $OB'r' = 45$  degrees, the output should decrease as  $jOB'r'$  is increased, and should increase as  $jOB'r'$  is decreased.

## Resolver B4089 \*6G

- a. When  $OL'$  or  $OZh = 0$ , the output = 0
- b. Set  $OZh = 3200$  min,  $OL' = 800$  min,  $jOB'r' = 0$ , the output should be at maximum positive value (+2.729 volts). The output to decrease when  $jOB'r'$  is moved either way from zero.
- c. The sign of the output should reverse when the DIRECTOR SELECTOR switch is thrown to AA.

## \* SIGNAL TEST SELECTOR switch position.

Es Computation Test. The elements shown in figure 48 are checked separately in this test. Reference height,  $H_s$ , and range,  $R$ , are the only inputs involved. Connect the test unit, and energize the computer as for operation, but leave the time motor turned off. Run the test according to table 31, reading and recording the check voltages as well as the values for Es.

Et and OR Computation Test. This test checks the elements shown on figures 48, 50, 52, and 53. All inputs (table 32)

are controlled manually. To bypass the plotter and limit the scope of this test, reference and target-coordinate input settings are made in conjunction with the test unit. The deck-tilt corrector elements are eliminated, for further simplification, by locking the two output servo loops on zero.

The problem results shown in table 32 fall into three categories: ten check voltages representing electrical intermediate quantities; one mechanical

Table 31

TEST FOR ELEVATION POINT OF AIM, Es, COMPUTATION

Settings		Check Voltages			Results		
Hs Ft	R Yds	1A R4002 R	1B B4080-R2 Es	1D R4005 Hs	Es		Error Min
					Calc 2000 = 0 Min	Read 2000 = 0 Min	
100	5000	+ 1.175	-0.008	+ 0.236	2023		
1000	6000	+ 1.410	-0.078	+ 2.358	2191		
2500	20,000	+ 4.700	-0.196	+ 5.895	2143		
4000	35,000	+ 8.225	-0.313	+ 9.432	2131		
5000	50,000	+11.750	-0.392	+11.789	2115		
300	40,000	+ 9.400	-0.024	+ 0.707	2009		
1200	30,000	+ 7.050	-0.094	+ 2.829	2046		
3000	15,000	+ 3.525	-0.235	+ 7.074	2229		
5000	5000	+ 1.175	-0.392	+11.789	3168		
					Total	Allow	
					Average		
					Maximum		

Table 32

TEST FOR TARGET ELEVATION, Et, AND TARGET RANGE, OR

Settings

R Yds	B'r' Deg Min	Hs Ft	Ht Ft	Xj Yds
1500	30°00'	0	0	0
5000	75°00'	100	300	East 100
6000	135°00'	1000	1200	East 300
20,000	240°00'	2500	3000	West 600
35,000	300°00'	4000	3900	West 750
50,000	0°00'	5000	5000	East 1000

Settings

Yj Yds	Xa 2F Read	Ya 3C Read
0	0	0
North 100	+0.235	+0.235
South 500	+1.175	+2.350
North 400	-3.525	-1.175
South 750	-7.050	+4.700
North 1000	+10.575	+10.575

Table 32 (Cont'd)

## TEST FOR TARGET ELEVATION, Et, AND TARGET RANGE, OR

## Settings

Xt 3A Read	Yt 3E Read
0	0
-1.175	-1.175
-1.763	-2.350
+2.820	+1.410
+5.875	-5.875
-9.400	-9.400

## Check Voltages

2C B4081-R2 B	2D B4081-R3 B	2E R4016 Xj	3B R4017 Xy	4A R4006 Ht	3G B4082-R4 OB
-0.176	- 0.305	0.000	0.000	0.000	0.000
-1.135	- 0.304	- 1.097	- 1.097	+ 0.707	0.000
-0.995	+ 0.995	- 3.291	+ 5.485	+ 2.829	0.000
+4.067	+ 2.348	+ 6.582	- 4.388	+ 7.074	0.000
+7.118	- 4.109	+ 8.227	+ 8.227	+ 9.196	0.000
0.000	-11.743	-10.970	-10.970	+11.863	0.000

Table 32 (Cont'd)

TEST FOR TARGET ELEVATION, Et, AND TARGET RANGE, OR

Check Voltages

3F B4082-R3 OB	4B B4095-R2 Et	4C B4095-R3 Et	4D R4008 OR
+ 0.353	0.000	- 0.353	+ 0.352
+ 2.452	0.000	- 2.452	+ 2.451
+ 1.993	0.000	- 1.995	+ 1.994
+ 4.298	0.000	- 4.304	+ 4.302
+ 7.971	0.000	- 7.977	+ 7.973
+10.846	0.000	-10.853	+10.847

Intermediate Quantity

Calc Deg Min	OB		Error Min
	Read Deg Min		
30°00'			
58°52'			
123°57'			
234°36'			
309°51'			
355°02'			
	Total		Allow
	Average		
	Maximum		

Table 32 (Cont'd)

## TEST FOR TARGET ELEVATION, Et, AND TARGET RANGE, OR

## Final Results

Et			OR		
Calc 2000 = 0 Min	Read 2000 = 0 Min	Error Min	Calc Yards	Read Yards	Error Yards
2000			1500		
2033			10433		
2162			8491		
2188			18315		
2132			33944		
2124			46182		
Total	Allow		Total	Allow	
Average			Average		
Maximum			Maximum		

intermediate quantity dial reading; and dial readings of the two transmitted outputs, Et and OR. The Et and OR computation test is performed as follows:

1. Connect the test unit to the computer.
2. Remove cover No. 6, and disconnect the line phase from the jOB'r' and jOB'r' - jB'r' servo motors. Set and lock the jOB'r' and jOB'r' - jB'r' dials at zero.
3. Set and hold Co at zero.
4. Set the So counter on zero.
5. Energize the computer as for operation, but leave the time motor turned off.

6. Apply the inputs listed under settings in table 32. Using the REF SHIP and TARGET coordinate handcranks, the input values shown for Xa, Ya, Xt, and Yt are set up on the test-unit dials with the TEST SELECTOR switch at the positions designated.

7. Read and record all electrical and mechanical values covered in the columns of table 32 under the headings CHECK VOLTAGES, INTERMEDIATE QUANTITY, and FINAL RESULTS. Compare each reading with the specified value and note the error.

Xp and Yp Computation Test. Although primarily a test for the plotting elements shown on figure 51, this test also involves most of the computing and switching elements shown on figures 48, 49, and 50. Each of the problems, table 33, consists

of first manually setting the Xp and Yp counters and the R, Hs, and B'r' indicators at specified values that represent the position of a reference point on which the director is trained. Ship-course and deck-tilt correction are fixed at zero. The plot then is shifted to own ship, where the values of  $Rh \sin B$  and  $-Rh \cos B$ , derived from range, bearing, and reference height, enter into the computation of Xp and Yp, the counters for which assume new positions. These represent the final problem results given under Results, table 33. In addition, seven check voltages to be measured with the test unit are tabulated for checking intermediate points. The procedure is:

1. Connect the test unit to the computer.
2. Remove cover No. 6, and disconnect the line phase from the jOB'r' and jOB'r' - jB'r' servo motors. Set and lock the jOB'r' and jOB'r' - jB'r' dials at zero.
3. Remove cover No. 1 for access to the Xp and Yp counters.
4. Set and hold Co at zero.
5. Energize the computer as for operation, but leave the time motor turned off.
6. Set the mode-and-plot switch at SHORE BOMB REF, and apply the inputs in the order listed in the first six columns of table 33. The values for Xa and Ya are set up on the Xp and Yp counters, respectively, by turning the REF SHIP hand inputs.
7. Turn the mode-and-plot switch to SHORE BOMB SHIP.
8. Read on the test-unit dials all check voltages for which calculated values are given. Compute the errors.

9. Read and record the problem results on the Xp and Yp counters. Record the errors.

Ph Computation Test. Trouble in the parallax group of elements shown in figure 59 can be analyzed by means of this test. Inputs of range and director train are set in manually as specified in table 34. The test unit is used for indicating the intermediate electrical quantities (check voltages), and the output, Ph, is read directly on the transmitted dial. The computer must be energized for operation (time motor turned off), and cover No. 6 removed to gain visual access to the Ph dial.

#### GENERATION TEST ANALYSIS

The sections of the computer that contribute to the results of the generation tests are block-diagrammed in figure 45. Detailed functional schematics for the various sections are given in figures 47, 50, and 51.

After taking the necessary steps to verify the problem results, make an analysis of the rate errors based on tables 35 and 36. Examine the errors of all problems to establish a pattern of symptoms along the same lines as those covered in the tables. If the symptoms are similar to those symptoms shown in the appropriate table, then the possible source indicated should be investigated. Refer to section 5.5 of this chapter for the procedure given under the adjustment number listed in the table, and perform the steps of the procedure. Refine the adjustment as necessary, taking into consideration the test results as well as the indications observed in performing the adjustment procedure. If an adjustment cannot be corrected to give the specified performance, look for mechanical trouble in the associated gearing and mechanism.

As shown on figure 45 the two generating mechanism groups have a common time source. Furthermore, the time input for

Table 33

## TEST FOR Xp AND Yp COMPUTATION

## Settings\*

R Yds	Hs Ft	B'r' Deg Min	Xa** 16.4 = 0 In	Ya** 16.4 = 0 In	Scale
500	0	30°00'	16.40	16.40	10,000:1
5000	100	75°00'	14.96	17.84	25,000:1
6000	1000	135°00'	11.40	26.40	36,000:1
20,000	2500	240°00'	27.20	12.80	50,000:1
35,000	4000	300°00'	31.83	26.69	70,000:1
50,000	5000	0°00'	0.20	32.60	100,000:1

## Check Voltages\*\*\*

4G R4001 SF	2G R4010 Xa	7F B4081-R2 B	4E R100 Xp	3D R4011 Ya	7G B4081-R3 B	4F R101 Yp
1.20	0.000	-0.059	0.538	0.000	- 0.102	0.519
3.00	0.235	-1.135	0.945	0.235	- 0.304	1.387
4.32	1.175	-0.995	2.146	2.350	+ 0.995	3.830
6.00	-3.525	+4.067	3.135	-1.175	+ 2.348	3.471
8.40	-7.050	+4.109	2.422	4.700	- 7.118	2.700
12.00	10.575	0.000	11.319	10.575	-11.743	5.073

\*Set jOB'r' and (jOB'r' - jB'r') dials on zero. Set Co receiver at electrical zero and So counter on zero.

\*\*Set switch S4006 on SHORE BOMB REF and read Xa and Ya inputs on Xp and Yp counters, then set switch S4006 to SHORE BOMB SHIP.

\*\*\*Check voltages to be used only when final results are not within allowable limits.

Table 33 (Cont'd)

TEST FOR Xp AND Yp COMPUTATION

Results

Xp		
Calc In.	Read In.	Error In.
17.300		
21.915		
15.636		
14.740		
16.250		
0.200		
Total	Allow	
Average		
Maximum		

Results

Yp		
Calc In.	Read In.	Error In.
14.959		
15.977		
30.636		
19.994		
17.690		
14.610		
Total	Allow	
Average		
Maximum		

Table 34

## TEST FOR HORIZONTAL PARALLAX, Ph, COMPUTATION

Settings		Check Voltages			Results		
R Yards	B'r' Deg	1E B4096-R4 B'r'	1F R4015 R	1G R4007 Ph	Ph		
					Calc Deg Min	Read Deg Min	Error Min
1000	30°00'	- 6.000	+0.052	-2.809	2°52'		
5000	75°00'	-11.591	+0.101	-1.085	1°06'		
6000	135°00'	- 8.485	+0.074	-0.662	0°41'		
20,000	240°00'	+10.392	-0.091	+0.243	-0°15'		
35,000	330°00'	+ 6.000	-0.052	+0.080	-0°05'		
50,000	0°00'	0.000	0.000	0.000	0°00'		
					Total	Allow	
					Average		
					Maximum		

the test runs is controlled by a stop watch rather than with a computer time dial, making it possible for a malfunctioning time-motor regulator to introduce errors in all three generated quantities. If the time-motor regulator is not functioning properly, then all problems of both tests will be fast or all will be slow as indicated in tables 35 and 36. If this is the case, run the complete test of the time-motor regulator, table 22 and replace or adjust the unit as required. For information on servicing the time-motor regulator, refer to OP 1140A.

If the error pattern fails to fall into one of the tabulated categories, more than one source of error is possible or the coordinates' inputs group or plotter group may be at fault. Whichever of these two possibilities seems more likely should be eliminated

first. The possibility of more than one source of error or more than one incorrect adjustment can be eliminated by performing the procedures for all the adjustments listed in table 35, in the order presented in section 5.5. To check the performance of the coordinates' input group and the plotter group, run the test for Xp and Yp computation, table 33. This test covers the computer elements from the coordinate inputs through the mode-and-plot switch to the plotter group, and contains intermediate check voltages for locating trouble in those groups.

## TRANSMISSION TEST ANALYSIS

The first thing to determine, when transmission errors are encountered, is whether the trouble originates within the computer

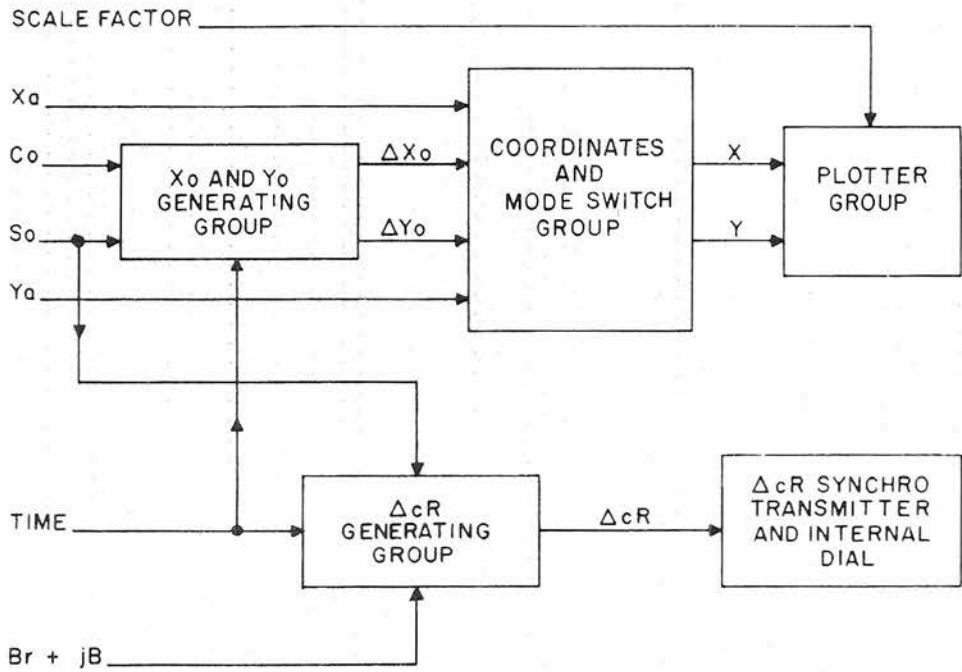

Figure 45. Generation Test Analysis, Block Schematic

Table 35

 $\Delta X_0$  AND  $\Delta Y_0$  ERROR ANALYSIS

Symptoms	Possible Source
All problems fast or all problems slow with errors proportional to $S_0$ .	Time-motor regulator
All problems fast or all problems slow with approximately equal rate errors.	$S_0$ to mechanical resolver — A58
All problems exhibit a course deviation in the same direction.	$C_0$ to mechanical resolver — A65
1st problem fast and 4th slow or 1st problem slow and 4th fast.	$dY_0$ to integrator carriage — A70 or A114
3rd problem fast and 5th slow or 3rd problem slow and 5th fast.	$dX_0$ to integrator carriage — A69 or A115

Table 36

 $\Delta cR$  ERROR ANALYSIS

Symptoms	Possible Source
All problems fast or all problems slow with errors proportional to $S_0$ .	Time-motor regulator
All problems fast or all problems slow with approximately equal errors.	$S_0$ to mechanical resolver — A66
1st and 4th problems slow and 2nd problem fast or 1st and 4th problems fast and 2nd problem slow.	$Br$ to mechanical resolver — A67
1st and 5th problems slow and 2nd, 3rd, and 4th problems fast or 1st and 5th problems fast and 2nd, 3rd, and 4th problems slow.	$dR$ to integrator carriage — A68 or A116

or from the external transmission system. Most cases of receiver instability or complete failure to respond can be assumed to be the fault of a receiver element. However, in cases where a receiver responds but fails to synchronize at the correct value, or where the computer transmitter unit fails the transmission test, the trouble can originate at either end of the transmission circuit or in the wiring between.

After checking out any electronic elements involved to the extent made possible by use of the neon indicating system, the trouble can be localized roughly by the substitution method. Disconnect the external circuit from the computer terminal block, and connect in its place the cable of an appropriate synchro test set—a test transmitter or test receiver. Rerun the transmission test with the test set. Compare the results obtained with the test set with those obtained under normal conditions. The result will establish whether the trouble is within the computer or external.

If the trouble is external, the receiving or transmitting unit at the other end of the circuit should be checked and, if necessary, followed by a check of the interconnecting wiring. Refer to BuOrd dwg 1371758 for external cable connections.

When transmission errors are localized to the computer, the following procedure is recommended:

#### Receivers (Double Speed)

1. Remove the servo control, and substitute a good spare. Rerun the test.

2. Remove the servo amplifier, and substitute a good spare. Rerun the test.

3. Refer to pertinent schematic, figures 47 through 59, and list the numbers of all adjustments of the receiver in question. Then refer to section 5.5 for the procedures given under the numbers listed. Perform each of the procedures in the order given, and readjust as necessary.

4. If the preceding steps have not eliminated the trouble, use an analyzer to check the windings of the synchros and servos for shorts or opens. Replace any defective units and readjust as necessary.

#### Ship's Speed Receiver

Maintenance for this receiver is covered in OP 1140A.

#### Transmitters

1. Refer to the pertinent schematic, figures 47 through 59, for the numbers of the adjustments that affect the accuracy of the transmitter. Perform the procedures for these adjustments, as given in section 5.5.

2. If the preceding procedures fail to eliminate the trouble, use an analyzer to check the windings of the transmitter synchros. Replace defective units and readjust.

#### INDEX-LIGHT TRAVEL TEST ANALYSIS

The electronic and mechanical units of the plotter and scale factor groups are shown in figure 51. Whether the errors are due to mechanical or electrical difficulties can be determined as follows:

#### Mechanical

With the computer de-energized, slowly run the index-light manually from one end of the plotter to the other, and back again. Check that there is no stiffness, tight spots, or any other mechanical irregularities. The motion should be smooth and continuous. Also, check each gear mesh for excessive lost motion. If mechanical trouble is found, refer to OP 1140A for gearing maintenance. In the absence of any mechanical irregularities, the source of trouble should be assumed to be electrical.

## Electrical

Using the neon system, check the servo controls and servo amplifiers for correct operation. Check the servo action of the Xp and Yp loops as follows:

Manually displace the output gearing of the Xp and Yp servos from synchronization and release it. Check that the gearing returns to the synchronous position with positive action. If the servo tends to drive sluggishly or to oscillate, substitute a new servo control or new servo amplifier, and check the servo action again. It also may be possible to improve the servo action by readjusting the servo control potentiometers. Information for this procedure is given in section 5.4.

## SCHEMATICS OF COMPUTING MECHANISMS

The following schematics of the computing mechanisms are presented for easy reference according to the principal functions with which a group of mechanisms is associated. All irrelevant matter has been omitted to facilitate study of a particular group of mechanisms. To be certain that the symbols used in the schematics are being interpreted correctly, refer to figure 17.

The individual schematics are drawn with their input sections toward the left-hand side of the page, with their respective computing mechanisms and outputs progressing toward the right-hand side.

The arrowheads on a schematic indicate quantity-travel, that is, the direction a quantity would be traveling under normal conditions, from its input to output or to the place where the quantity is used. In most cases, beginning with the output of a quantity, and tracing it step-by-step to its input source, will prove the most effective method of detecting a faulty mechanism.

## Servo Loops

The typical electronic servo loop is illustrated in figure 46, which shows the basic components represented by a single block on the functional schematics that follow. It consists of a servo control, servo amplifier, a rate generator, and a servo motor. There are 17 such servo loops used in this computer.

Each servo loop has a particular type of servo control, amplifier, motor, and rate generator associated with it. Components of one loop, therefore, cannot be interchanged indiscriminately with those of another. Table 37 identifies every component associated with each servo loop. The numerical designation of each loop is given on the schematics. It is only necessary to locate this same number in the extreme left-hand column of the table, and to trace horizontally across the columns for the desired information.

The complete set of schematics given on the following pages are listed for easy reference in table 38.

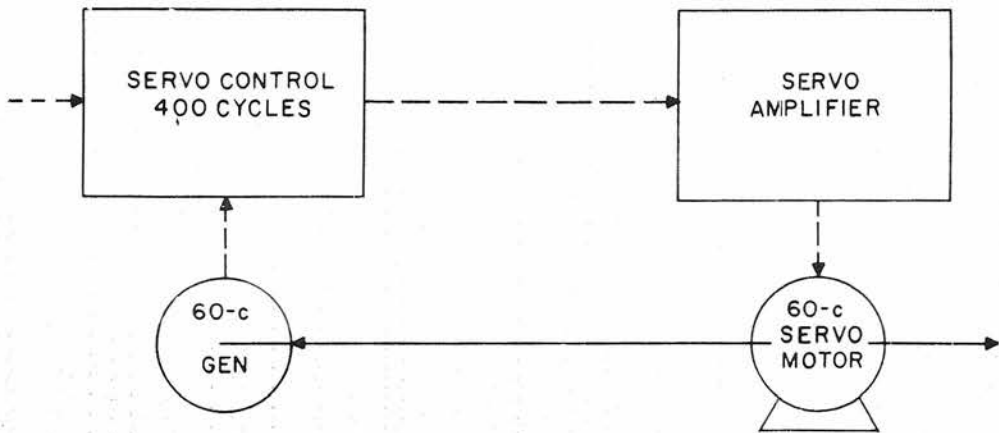

Figure 46. Typical Servo Loop

Table 37

## SERVO LOOP ELEMENTS

Servo Loop		Servo Controls			Servo Amplifier		Servo Motor		Generator
No	Function	Symbol	Type	Neon	Symbol	Neon	Symbol	Type	Symbol
2	R	ZB4102	2SVL	None	ZA4102	4113	B4002	5w	G4002
3	Ph	ZB4103	VL	4101	ZA4103	4114	B4003	5w	G4003
4	jB	ZB4104	HF	4102	ZA4104	4115	B4004	5w	G4004
5	Co	ZB4105	2SVL	None	ZA4105	4116	B4005	10w	G4005
6	B'r'	ZB4106	2SHF	None	ZA4106	4117	B4006	10w	G4006
7	Es	ZB4107	VL	4103	ZA4107	4118	B4007	5w	G4007
8	OR	ZB4108	VL	4104	ZA4108	4119	B4008	5w	G4008
9	Et	ZB4109	VL	4105	ZA4109	4120	B4009	5w	G4009
10	L'	ZB4010	HF	4106	ZA4110	4121	B4010	10w	G4010
11	Zh	ZB4311	HF	4107	ZA4311	4122	B4011	10w	G4011
12	OL'	ZB4112	2SHF	None	ZA4112	4123	B4012	10w	G4012
13	OZh	ZB4313	2SHF	None	ZA4313	4124	B4013	10w	G4013
14	jOB'r' -jB'r'	ZB4314	HF	4108	ZA4314	4125	B4014	10w	G4014
15	jOB'r'	ZB4315	HF	4109	ZA4315	4126	B4015	10w	G4015
16	OB	ZB4316	VL	4110	ZA4316	4127	B4016	10w	G4016
100	Xp	ZB4300	VL	4111	ZA4300	4128	B100	10w	G100
101	Yp	ZB4301	VL	4112	ZA4301	4129	B101	10w	G101

Table 38

## LIST OF FUNCTIONAL SCHEMATICS

Figure	Descriptive Title
47	$\Delta cR$ , $\Delta Yo$ and $\Delta Xo$ group
48	Es and Rh loop
49	jB loop and B resolver
50	Coordinate inputs and mode-and-plot switch group
51	Plotter group
52	ORh and OB computing loop
53	Et and OR loop
54	OL' and OZh resolver group
55	L' and Zh computing loops
56	jOB'r' - jB'r' loop
57	jOB'r' loop
58	OB'r' differentials
59	Parallax group

## Section 5.4—Trouble Shooting Electronic Units

## PROCEDURE

This section contains general information and instructions for trouble shooting defective electronic units which have been located through the procedures given in previous sections of this chapter. These trouble-shooting tests are essentially the same as those used by the manufacturer. These tests will enable fire controlmen to

test individual units in or out of the computer, locate the exact source of difficulty, and correct the defective unit.

When a malfunctioning electronic unit has been found, remove it from the instrument and immediately replace it with a spare that is in good condition. The main object is to return the computer to a satisfactory operative condition as quickly as possible.

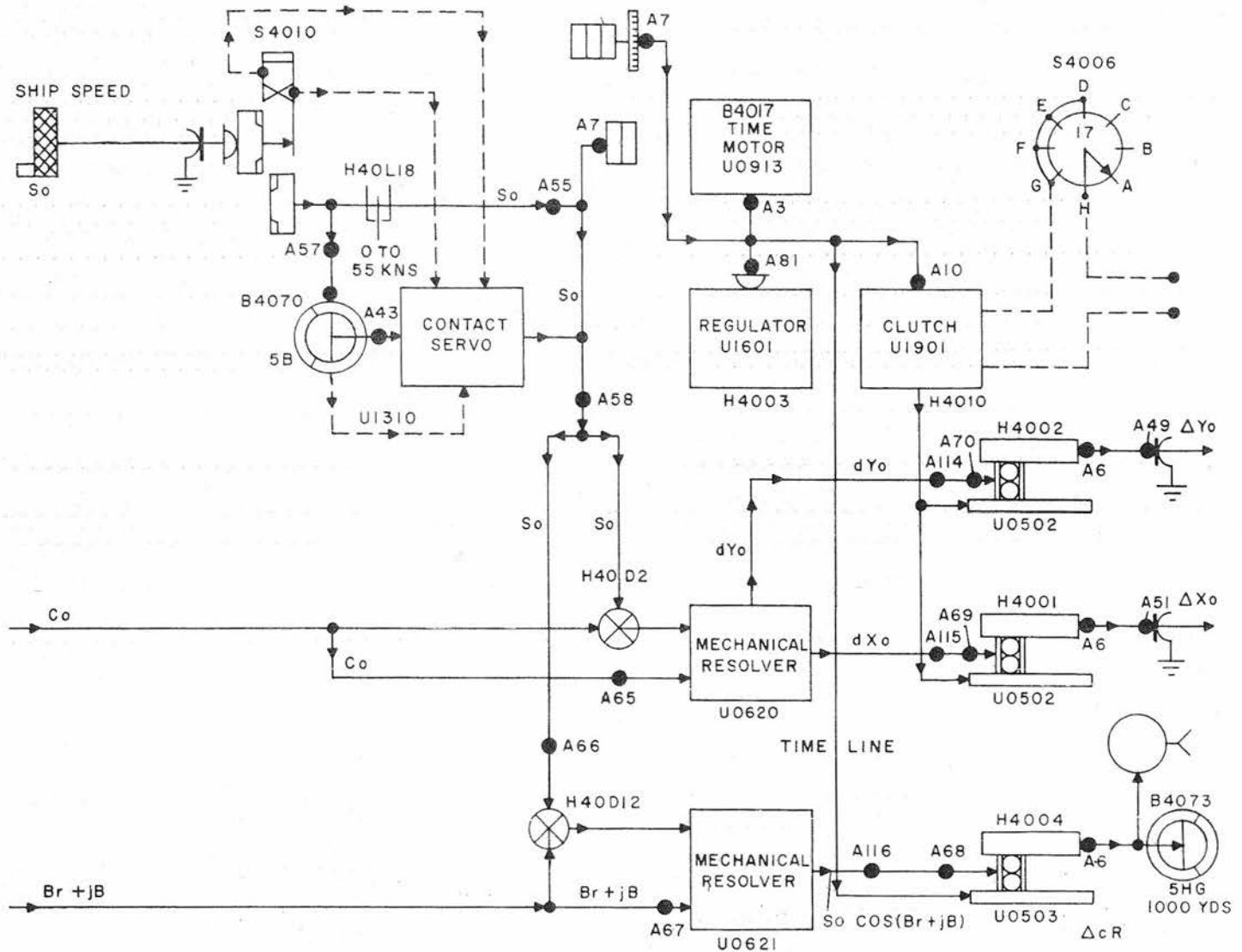

Figure 47.  $\Delta cR$ ,  $\Delta Y_o$ , and  $\Delta X_o$  Group



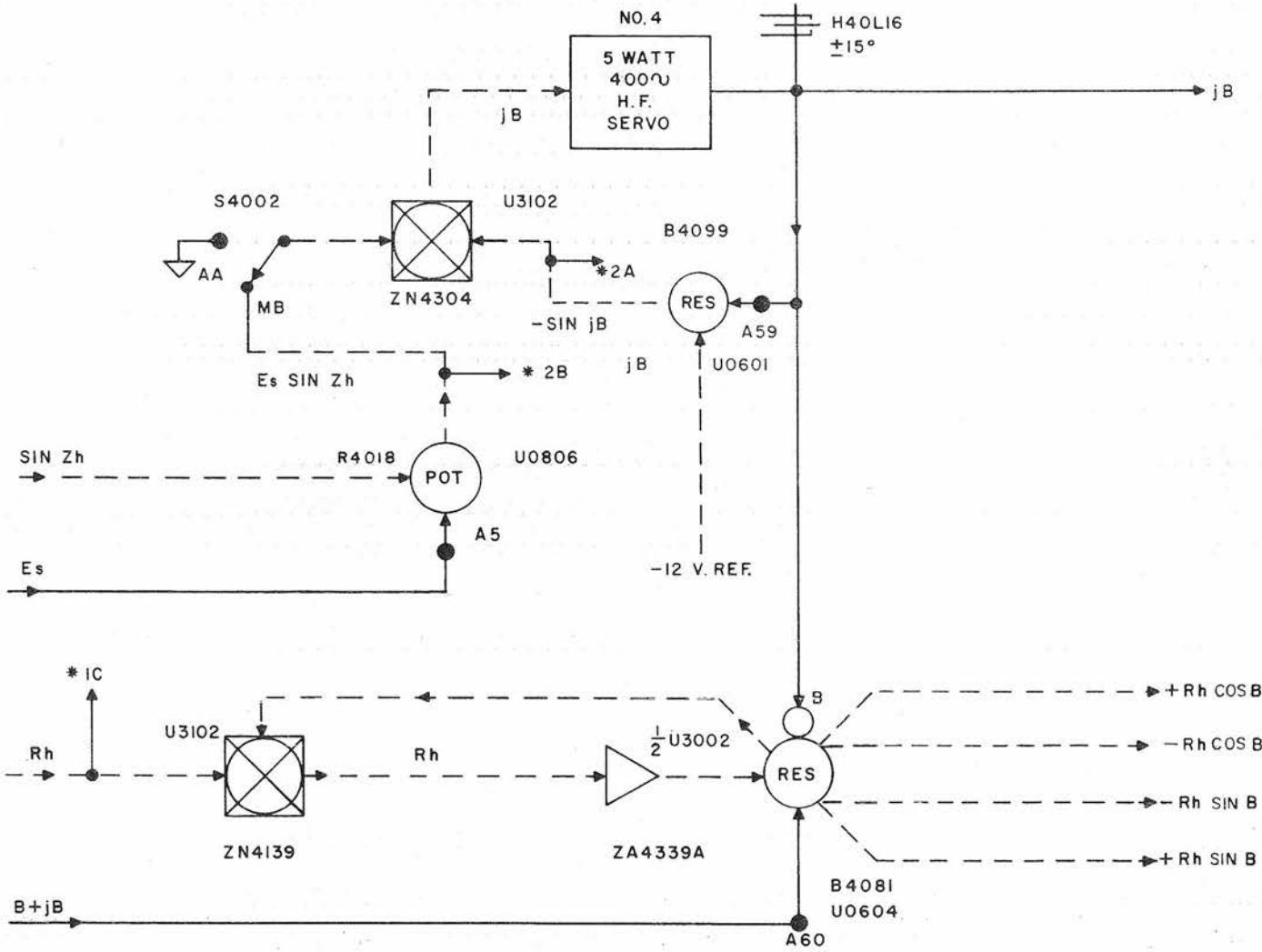

Figure 49. jB Loop and B Resolver

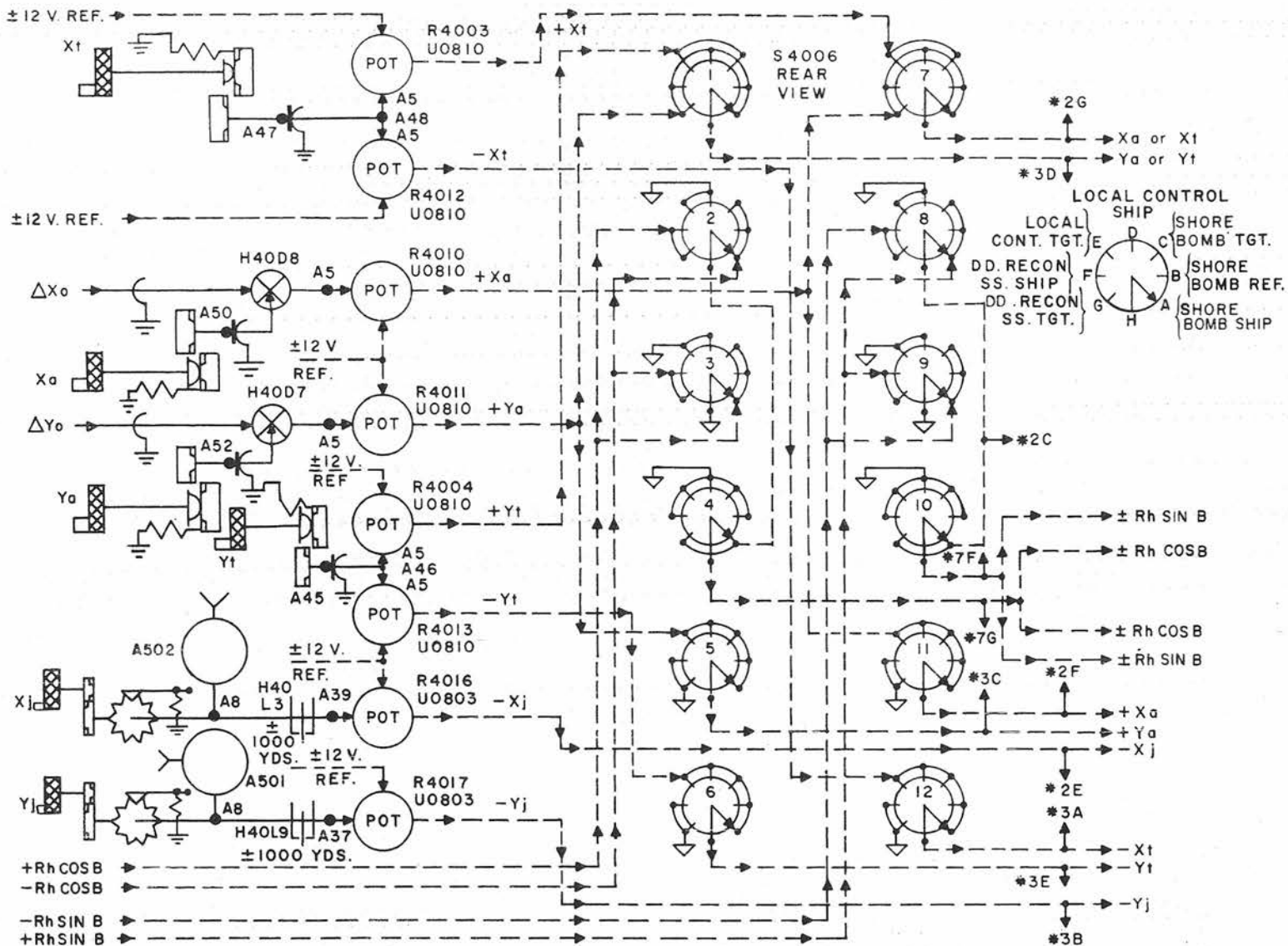

Figure 50. Coordinate Inputs and Mode-and-Plot Switch Group

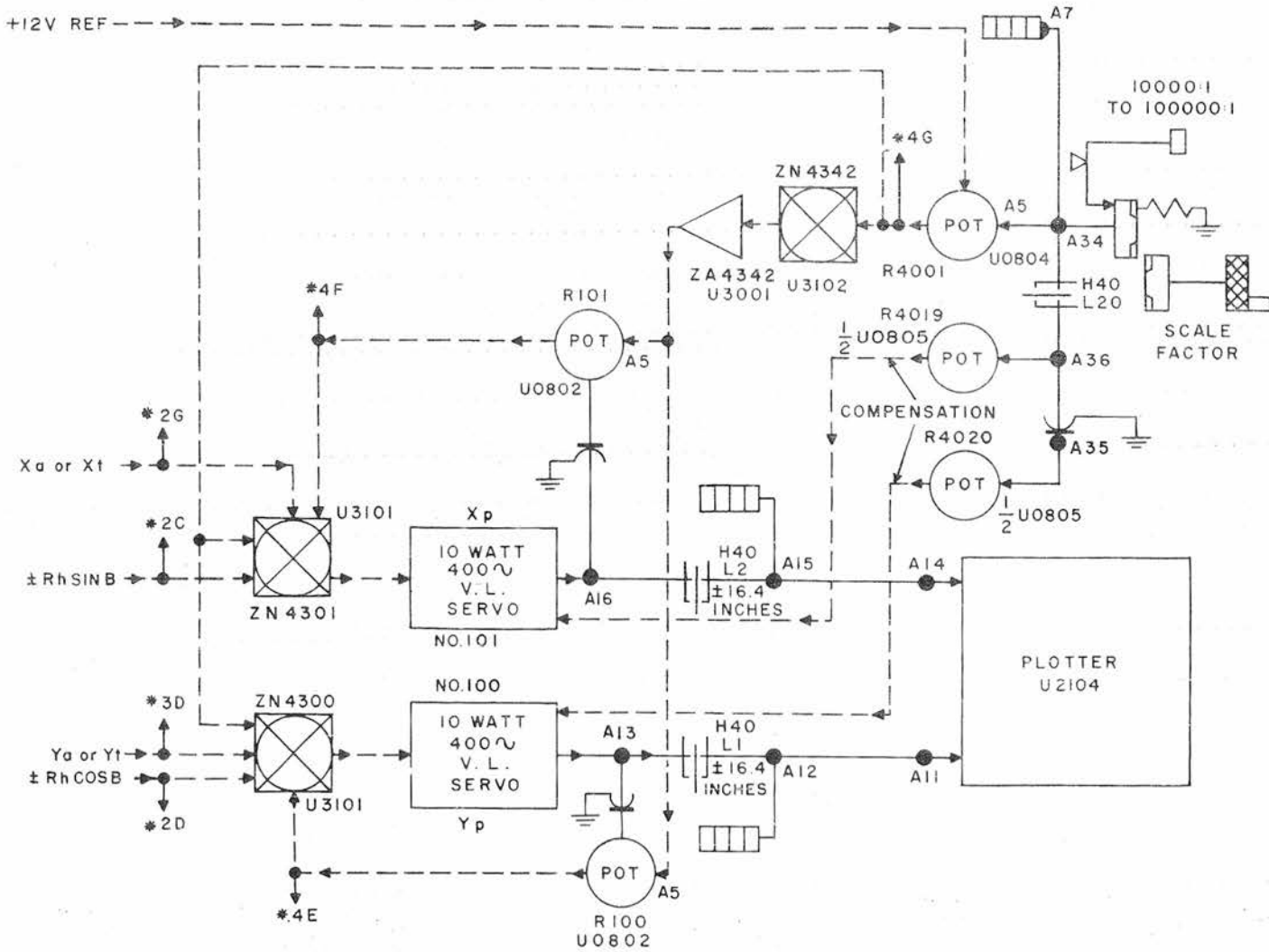

Figure 51. Plotter Group

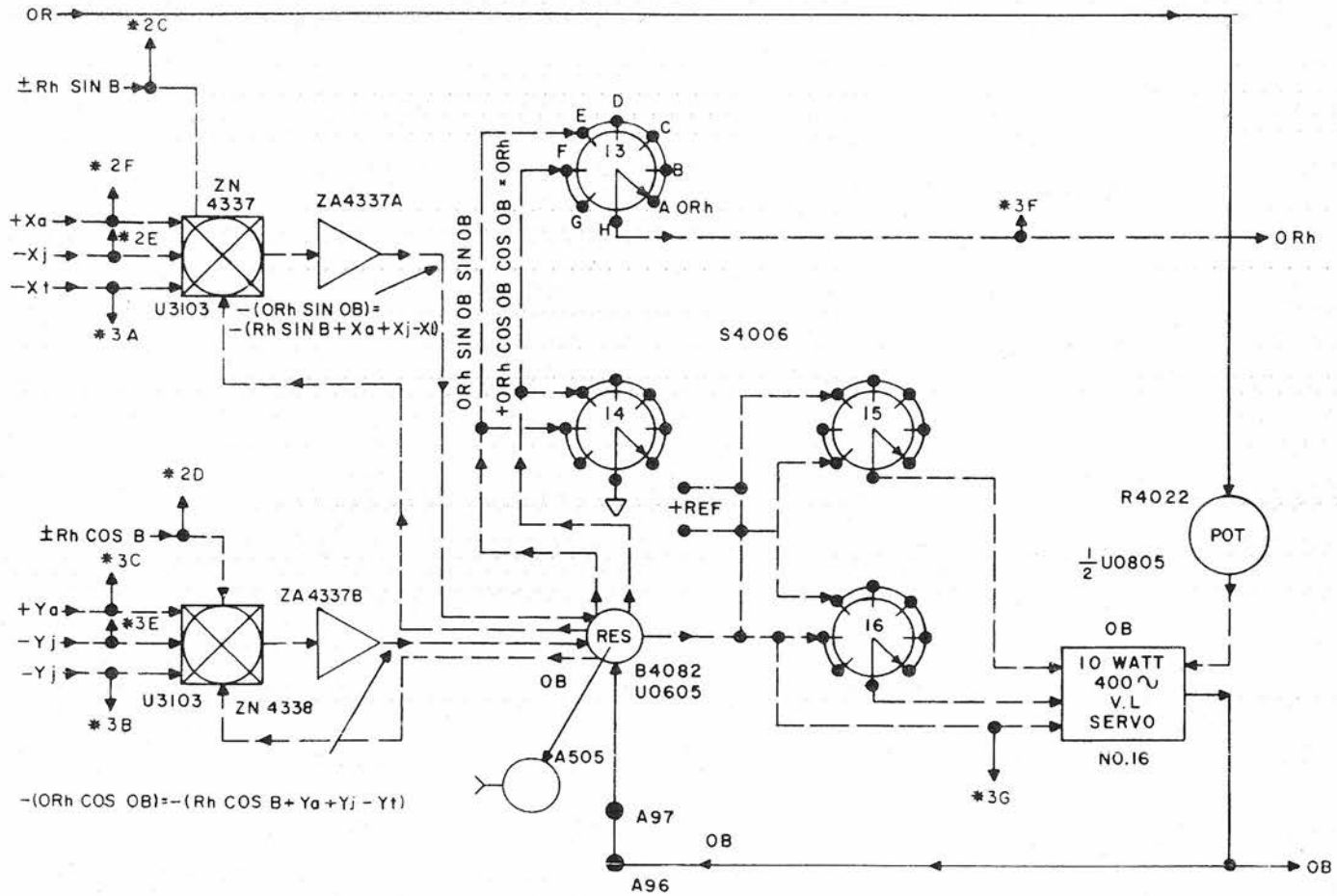

Figure 52. ORh and OB Computing Loop



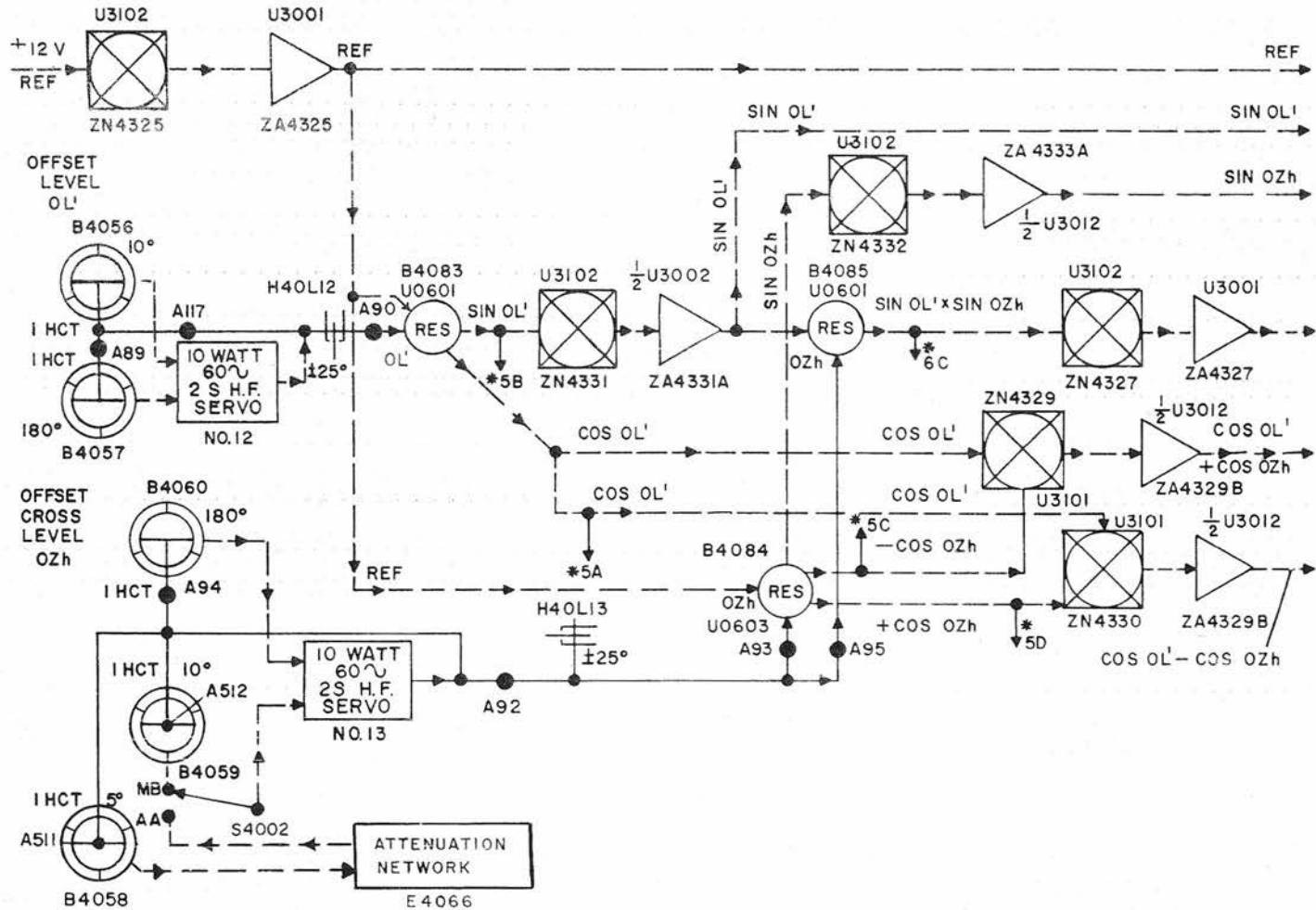

Figure 54. OL' and OZh Resolver Group

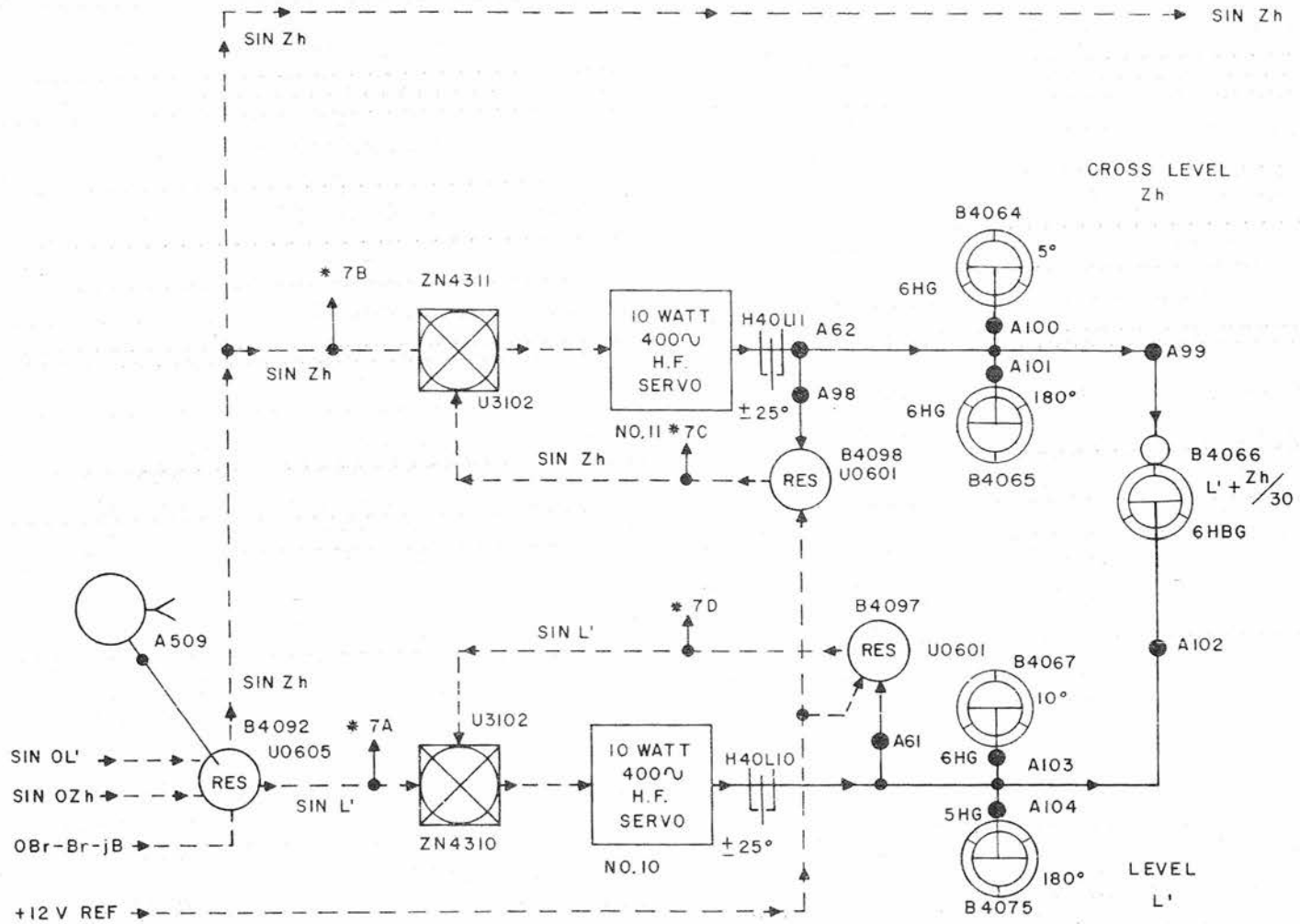
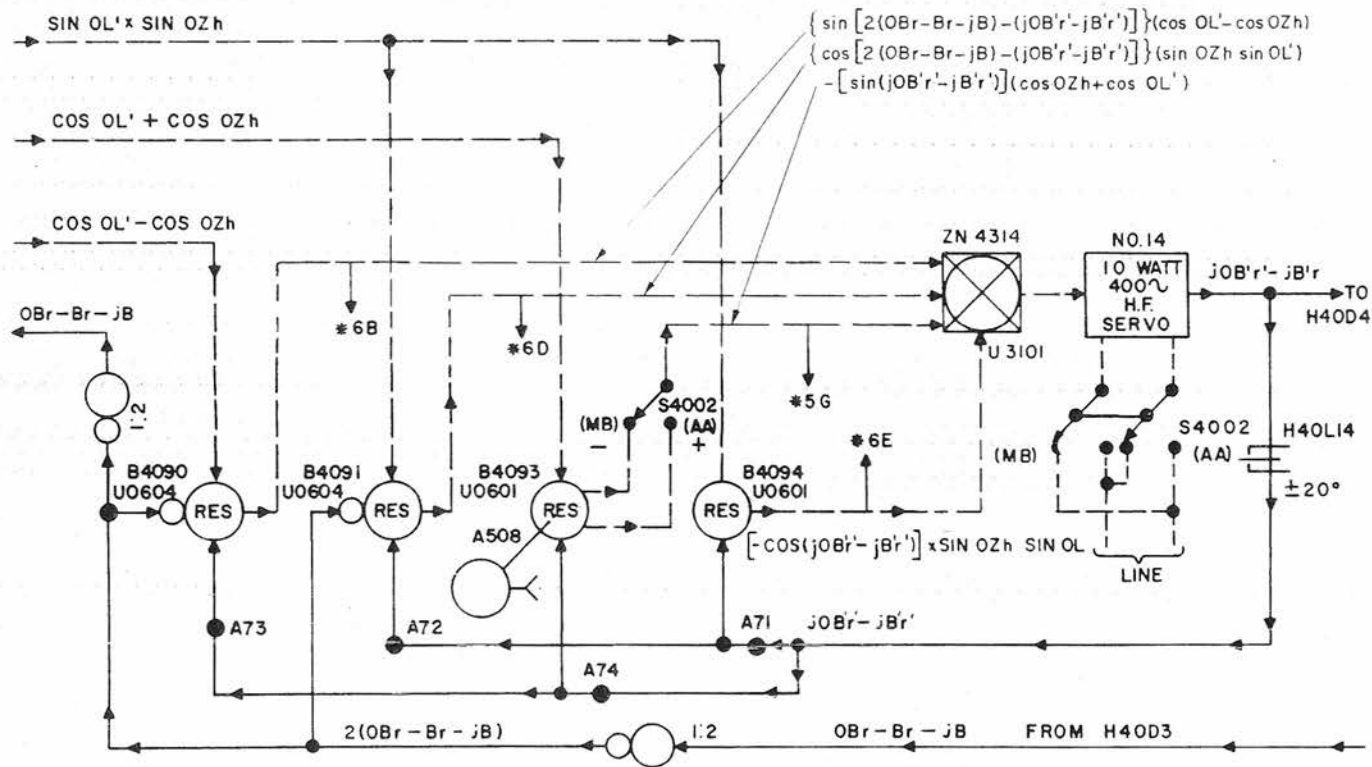

Figure 55. L' and Zh Computing Loops

Figure 56.  $jOB'r' - jB'r'$  Loop

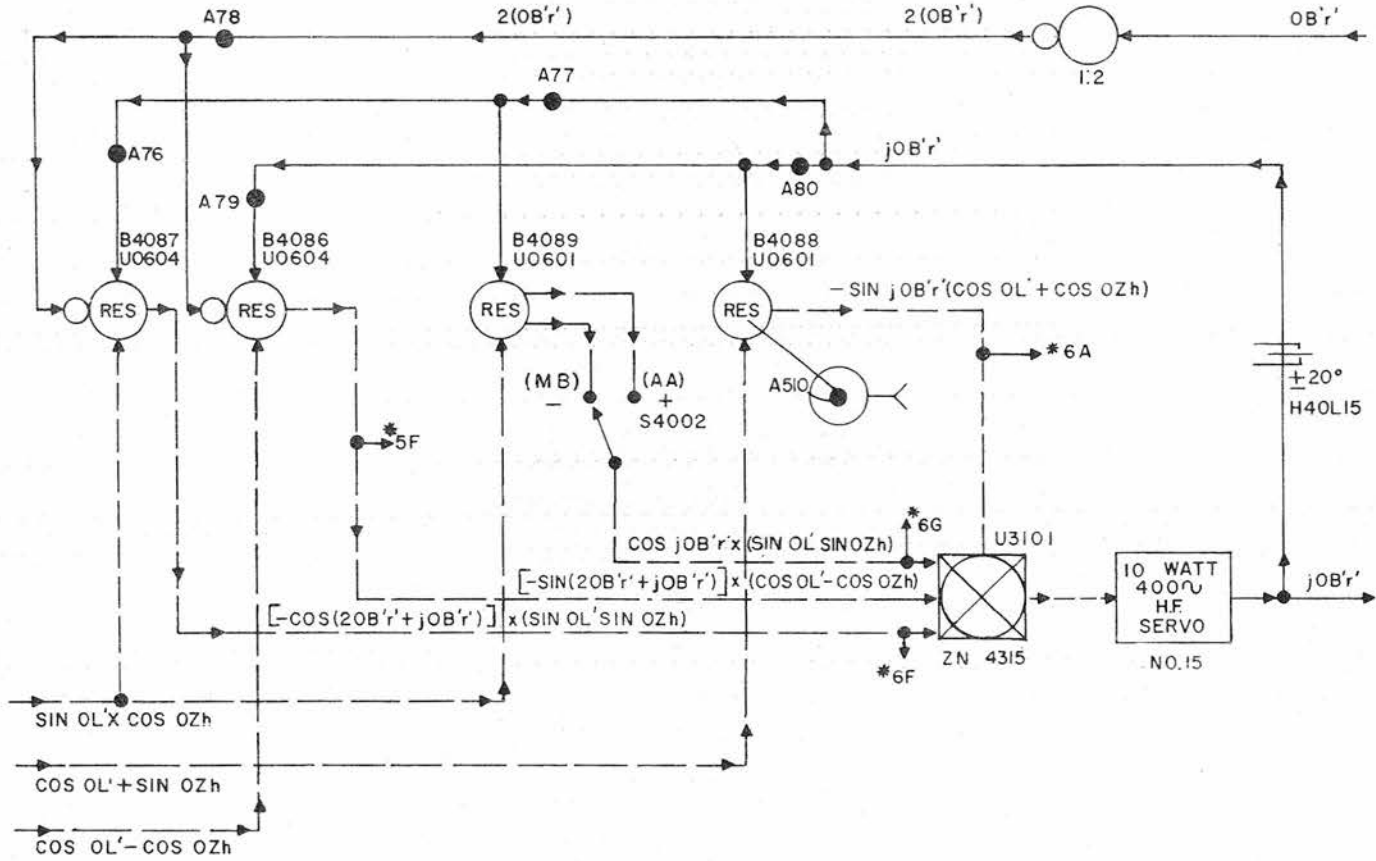

Figure 57.  $jOB'r'$  Loop

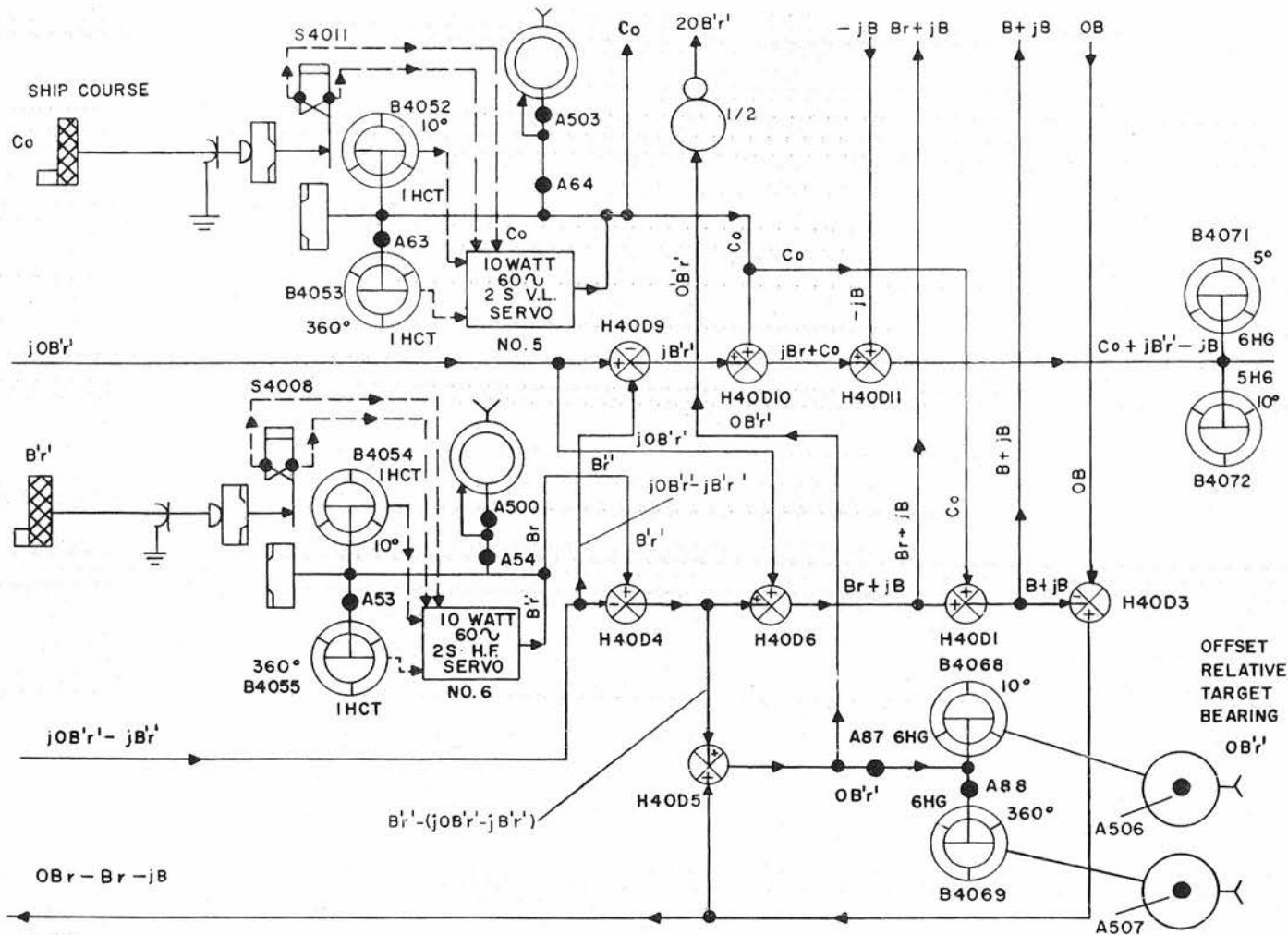

Figure 58. OB'r' Differentials

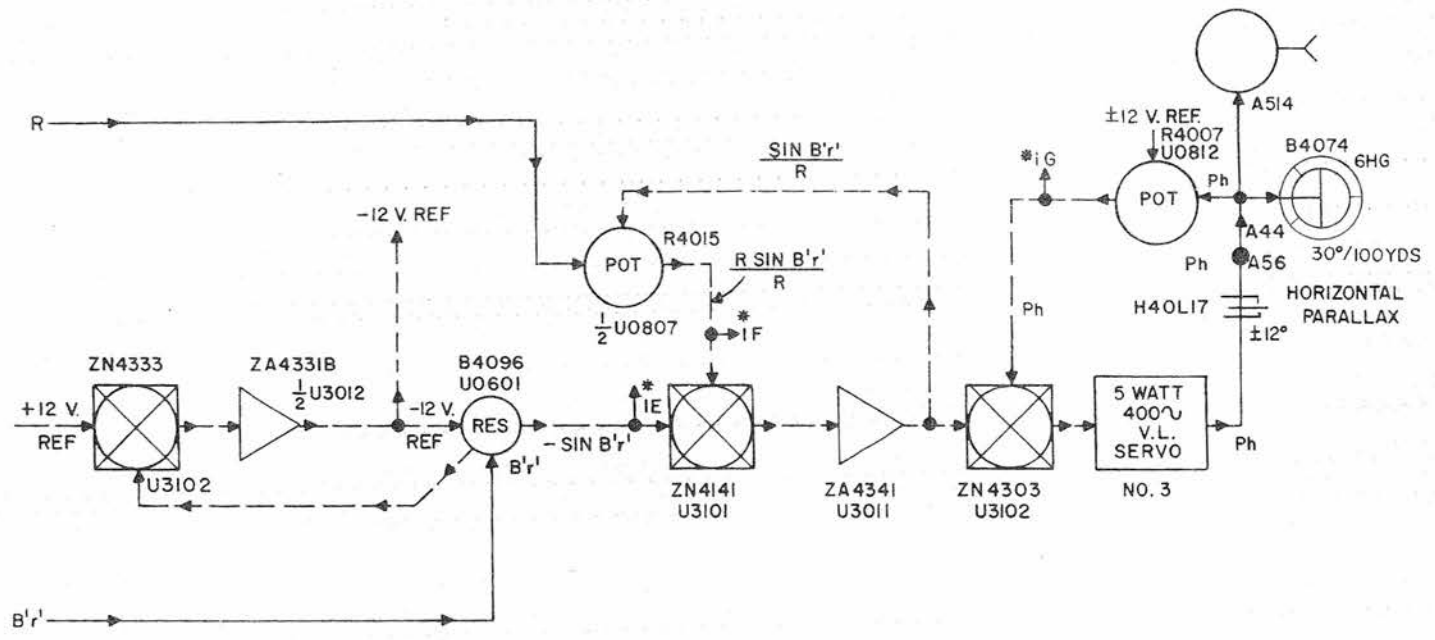

Figure 59. Parallax Group

### Preliminary Check

In general, examine a defective unit for visible signs of trouble and for electron-tube failure. Check to see if all soldered connections are good, both mechanically and electrically. Look for charring on insulation and resistors and leaking of compound from potted components due to overheating. Check for an odor of burned insulation from transformers and resistors, as both usually indicate shorts in the circuit. Replace damaged components and conduct a complete point-to-point resistance and voltage test to locate other circuit faults which may have caused the obvious damage to the parts that were replaced. Check the electron tubes by substituting good ones, one at a time, each time operating the element in the circuit and using the neon monitoring system to determine whether the trouble has been cleared. All tubes not requiring replacement should be reinstalled in the element sockets from which they were taken. If the preliminary check of components does not reveal the cause of failure, then the troubleshooting tests should be used to locate the source of trouble and to correct it.

### Trouble Shooting Tests

The trouble shooting tests for electronic elements consist of point-to-point measurements of circuit voltages and resistance. An element circuit schematic that shows the location of all test points is included with each test.

**Test Points.** Test point identification numbers are shown enclosed in circles on the schematic. These same numbers are found on the terminal boards in the element chassis adjacent to their respective terminals. Additional test points are the terminals of tubes, transformers, and panel connectors, any of which can be found correspondingly designated in the

test-data tables, on the circuit schematic, or in the element proper.

**Electrical Measurements.** Voltage readings are taken with the element plugged into its normal position in the computer and with the tubes installed. If the trouble is not localized during the voltage tests, remove the element from the computer to eliminate any effects other circuits may have on the measurements, remove all tubes, and conduct the resistance tests. All voltage and resistance measurements are made between the prescribed test points and chassis ground, unless otherwise noted. The number of test points covered for each element is sufficient to enable localization of trouble to a relatively small portion of the circuit.

To further localize the defective part, refer to the circuit schematic where values for individual circuit components are shown. When measuring resistance across points not covered in the tables, determine beforehand the total value for the points concerned. Consider all resistances in series or in parallel between the two points. Also, consider that each capacitor has infinite resistance, unless defective. If an incorrect resistance reading is obtained between two circuit points, disconnect one side of each component and measure it separately. Compare the value measured with the value specified in the schematic. If the error indicated exceeds the stated tolerance, replace the component with a new one of correct value and power rating. Replace any capacitor which, when tested separately, indicates other than infinite resistance.

After replacing a defective part, the resistance check should be re-run to make sure that the circuit has been corrected, then make a complete recheck of the voltages with the element plugged into the instrument. Before assigning the element to active or spare use, test it functionally in the computer by performing appropriate routine computer tests.

### Electronic Element Reference Table

Table 39 lists all of the electronic elements in the order of their element identification numbers, and contains pertinent maintenance information for each item. (Refer to Component Identification, section 5. 2) One purpose of this table is to show those elements that are interchangeable. All elements that have identical unit numbers, designation, and ordinance drawing numbers can be interchanged with one another. Also, the table serves as a guide in finding the physical location of an element in the electronic section of the computer. The key to element location listed in the fourth column of the table is explained in the following paragraph.

#### Location of Electronic Elements

To locate the position of an electronic element in the instrument, refer to table 39 and note the key letter in the location column opposite the designation symbol of the element. Then refer to figure 60, which is a left-side block diagram of the computer with the element racks drawn out and turned down (fully extended). The letters labeling the various sections correspond with those in the table and give the general location of an element. To find the exact position of an element in its section, figures 61 through 66 show elevation views of the sections and also are correspondingly labeled.

#### Access to Electronic Elements

Once the position of an element is determined, the appropriate panel can be removed by turning all fasteners one-quarter turn and lifting the panel off. Figures 43 and 67 show the front electronic section before and after panel removal. The front elements diagrammed in figure 61 (A in figure 60) thus are exposed, providing access to all test points and under-chassis components. Access to the rear

elements (figure 62 and B in figure 60) is gained by depressing the catch-release button, pulling the drawer out, and turning it down as shown in figures 68 and 69.

To gain access to the electron tubes, turn the fasteners to the release position and swing the top basket (of the two that make up the drawer) upward as shown in figure 70.

To remove an element from the basket, unscrew the retaining jack-screw (s), tilt the panel-connector end away from the basket, and withdraw the element from the two supporting dowel pins at the opposite end. Figure 71 shows the above-mentioned features of a typical electronic element withdrawn from the instrument.

Figures 72 through 85 are element circuit schematics that show the location of all test points. Test data for the point-to-point measurements, and all information too lengthy to include on the schematics, such as parts lists and notes, are given in tables 40 through 65.

#### Special Potentiometer Settings For Tests

Potentiometer adjustments are set by the manufacturer, and unless disturbed, ordinarily will not change in value. Most potentiometers are held in correct position by a detent action associated with its control shaft. Turning the control shaft of the potentiometer will correspondingly change the potentiometer value, but should not change the original detent position. When testing an electronic element the test procedure may require a potentiometer to be turned fully clockwise or counterclockwise before a measurement is taken. To turn the potentiometer, first partially unscrew the outer locking screw from the control shaft, and then turn the shaft in the direction specified in the test procedure. Upon completing the test, return the potentiometer to its original position by rotating the control shaft back over the

Table 39  
ELECTRONIC ELEMENTS

Element	Unit	Function	Location on Figure 60	Designation	Assembly BuOrd Dwg	Schematic BuOrd Dwg	Test Spec BuOrd Sk
ZA4102	3201	R	A	Servo amplifier 5- and 10-watt motor, 60-c	980405	980406	276960
ZA4103	3201	Ph	A	Servo amplifier 5- and 10-watt motor, 60-c	980405	980406	276960
ZA4104	3201	jB	A	Servo amplifier 5- and 10-watt motor, 60-c	980405	980406	276960
ZA4105	3201	Co	A	Servo amplifier 5- and 10-watt motor, 60-c	980405	980406	276960
ZA4106	3201	B'r'	A	Servo amplifier 5- and 10-watt motor, 60-c	980405	980406	276960
ZA4107	3201	Es	A	Servo amplifier 5- and 10-watt motor, 60-c	980405	980406	276960
ZA4108	3201	OR	B	Servo amplifier 5- and 10-watt motor, 60-c	980405	980406	276960
ZA4109	3201	Et	B	Servo amplifier 5- and 10-watt motor, 60-c	980405	980406	276960
ZA4110	3201	L'	B	Servo amplifier 5- and 10-watt motor, 60-c	980405	980406	276960
ZA4112	3201	OL'	B	Servo amplifier 5- and 10-watt motor, 60-c	980405	980406	276960

Table 39 (Cont'd)

## ELECTRONIC ELEMENTS

Element	Unit	Function	Location on Figure 60	Designation	Assembly BuOrd Dwg	Schematic BuOrd Dwg	Test Spec BuOrd Sk
ZA4145	3402	Ref v	C	Tuning-fork amplifier	1372170	1372171	285623
ZA4300	3201	Xp	E	Servo amplifier 5- and 10-watt motor, 60-c	980405	980406	276960
ZA4301	3201	Yp	E	Servo amplifier 5- and 10-watt motor, 60-c	980405	980406	276960
ZA4311	3201	Zh	F	Servo amplifier 5- and 10-watt motor, 60-c	980405	980406	276960
ZA4313	3201	OZh	F	Servo amplifier 5- and 10-watt motor, 60-c	980405	980406	276960
ZA4314	3201	jOB'r' - jB'r'	F	Servo amplifier 5- and 10-watt motor, 60-c	980405	980406	276906
ZA4315	3201	jOB'r'	F	Servo amplifier 5- and 10-watt motor, 60-c	980405	980406	276608
ZA4316	3201	OB	E	Servo amplifier 5- and 10-watt motor, 60-c	980405	980406	276608
ZA4325	3001	Ref v	E	Amplifier, single-channel, computing, 400-c	980431	980432	276958
ZA4327	3001	Sin OL' x sin OZh	E	Amplifier, single-channel, computing, 400-c	980431	980432	276958

Table 39 (Cont'd)  
ELECTRONIC ELEMENTS

Element	Unit	Function	Location on Figure 60	Designation	Assembly BuOrd Dwg	Schematic BuOrd Dwg	Test Spec BuOrd Sk
ZA4329	3012	Cos OL' + cos OZh Cos OL' - cos OZh	E	Amplifier, dual-channel, resolver	1371930	1371931	285612
ZA4331	3012	Sin OL', ref v	E	Amplifier dual-channel, resolver	1371930	1371931	285612
ZA4333	3002	Sin OZh, R	E	Amplifier, dual-channel, resolver, 400-c	980156	980230	276632
ZA4335	3002	Ht, ORh	E	Amplifier, dual-channel, resolver, 400-c	980156	980230	276632
ZA4337	3002	ORh sin OB, ORh cos OB	E	Amplifier, dual-channel, resolver, 400-c	980156	980230	276632
ZA4339	3002	Rh, spare	E	Amplifier, dual-channel, resolver, 400-c	980156	980230	276632
ZA4341	3011	Ph	E	Amplifier, single-channel, 400-c, 500-ohm load	1371876	1371873	285607
ZA4342	3001	SF	E	Amplifier, single-channel, 400-c, 500-ohm load	980431	980432	276958

Table 39 (Cont'd)

## ELECTRONIC ELEMENTS

Element	Unit	Function	Location on Figure 60	Designation	Assembly BuOrd Dwg	Schematic BuOrd Dwg	Test Spec BuOrd Sk
ZB4102	3304	R	A	Servo control, vel-lag, 60-c, double-speed	980419	980420	276965
ZB4103	3301	Ph	A	Servo control, vel-lag, 400- to 60-c	980602	980604	276627
ZB4104	3302	jB	A	Servo control, high-fidelity, 400- to 60-c	1371797	1371982	285614
ZB4105	3304	Co	A	Servo control, vel-lag, 60-c, double-speed	980419	980420	276965
ZB4106	3305	B'r'	A	Servo control, high-fidelity, double-speed, 60-c	980422	980423	276956
ZB4107	3301	Es	B	Servo control, vel-lag, 400- to 60-c	980602	980604	276627
ZB4108	3301	OR	B	Servo control, vel-lag, 400- to 60-c	980602	980604	276627
ZB4109	3301	Et	B	Servo control, vel-lag, 400- to 60-c	980602	980604	276627
ZB4110	3302	L'	B	Servo control, high-fidelity, 400- to 60-c	1371797	1371982	285614
ZB4112	3305	OL'	B	Servo control, high-fidelity, 400- to 60-c	980422	980423	276956

Table 39 (Cont'd)

## ELECTRONIC ELEMENTS

Element	Unit	Function	Location on Figure 60	Designation	Assembly BuOrd Dwg	Schematic BuOrd Dwg	Test Spec BuOrd Sk
ZB4300	3301	Xp	E	Servo control, vel-lag, 400- to 60-c	980602	980604	276627
ZB4301	3301	Yp	E	Servo control, vel-lag, 400- to 60-c	980602	980604	276627
ZB4311	3302	Zh	F	Servo control, high-fidelity, 400- to 60-c	1371797	1371982	285614
ZB4313	3305	OZh	F	Servo control, high-fidelity, double-speed, 60-c	980422	980423	276956
ZB4314	3302	jOB'r' -jB'r'	F	Servo control, high-fidelity 400- to 60-c	1371797	1371982	285614
ZB4315	3302	jOB'r'	F	Servo control, high-fidelity 400- to 60-c	1371797	1371982	285614
ZB4316	3301	OB	F	Servo control, vel-lag 400- to 60-c	980602	980604	276627
ZC4101	3803	B+	C	+250 VDC series regulator	951989	951990	273343
ZC4102	3803	B+	C	+250 VDC series regulator	951989	951990	273343
ZC4103	3803	B+	C	+250 VDC series regulator	951989	951990	273343
ZC4104	3804	B-	C	-105 DC regulated power supply	979772	979827	276954

Table 39 (Cont'd)

## ELECTRONIC ELEMENTS

Element	Unit	Function	Location on Figure 60	Designation	Assembly BuOrd Dwg	Schematic BuOrd Dwg	Test Spec BuOrd Sk
ZM4101	1903		C	Time delay control, 60-c	979577	596437	273365
ZN4136	3102	ORh	C	Resistance summing networks	952085-1	979458-1	285600
ZN4139	3102	Rh	C	Resistance summing networks	952085-1	979458-1	285600
ZN4141	3101	Sin B'r'	C	Resistance summing networks	951731-88	137907	285600
ZN4300	3101	Yp	D	Resistance summing networks	951731-89	137907	285600
ZN4301	3101	Xp	D	Resistance summing networks	951731-89	137907	285600
ZN4303	3102	Ph	D	Resistance summing networks	952085-1	979458-1	285600
ZN4304	3102	jB	D	Resistance summing networks	952085-39	1371900-1	285600
ZN4307	3101	Hs	D	Resistance summing networks	951731-85	1371903	285600
ZN4308	3102	OR	D	Resistance summing networks	952085-40	1371900-2	285600

Table 39 (Cont'd)

## ELECTRONIC ELEMENTS

Element	Unit	Function	Location on Figure 60	Designation	Assembly BuOrd Dwg	Schematic BuOrd Dwg	Test Spec BuOrd Sk
ZN4310	3102	Sin L'	D	Resistance summing networks	952085-41	1371900-3	285600
ZN4311	3102	Sin ZH	D	Resistance summing networks	952085-41	1371900-3	285600
ZN4314	3101	jOB'r' -jB'r'	D	Resistance summing networks	951731-86	1371904	285600
ZN4315	3101	jOB'r'	D	Resistance summing networks	951731-86	1371904	285600
ZN4325	3102	Ref v	D	Resistance summing networks	952085-43	1371900-5	285600
ZN4327	3102	Sin OL' x Sin OZh	D	Resistance summing networks			
ZN4329	3101	Cos OL' + cos OZh	D	Resistance summing networks	951731-87	1371905	285611
ZN4330	3101	Cos OL' - cos OZh	D	Resistance summing networks	951731-90	1371908	285611
ZN4331	3102	Sin OL'	D	Resistance summing networks	952085-45	1371900-7	285611
ZN4332	3102	Sin OZh	D	Resistance summing networks	952085-41	1371900-3	285600

Table 39 (Cont'd)

## ELECTRONIC ELEMENTS

Element	Unit	Function	Location on Figure 60	Designation	Assembly BuOrd Dwg	Schematic BuOrd Dwg	Test Spec BuOrd Sk
ZN4333	3102	Ref v	D	Resistance summing networks	952085-1	979458-1	285600
ZN4334	3102	R	D	Resistance summing networks	952085-1	979458-1	285600
ZN4335	3101	Ht	D	Resistance summing networks	951731-85	1371903	285600
ZN4337	3103	Orh sin OB	D	Resistance summing networks			
ZN4338	3103	Orh cos OB	D	Resistance summing networks	952088-27	1371902	285600
ZN4342	3102	SF	D	Resistance summing networks	952085-7	979458-7	285600
ZY4101	3401	Ref v	C	Tuning-fork oscillator	1372162	1372163	285702

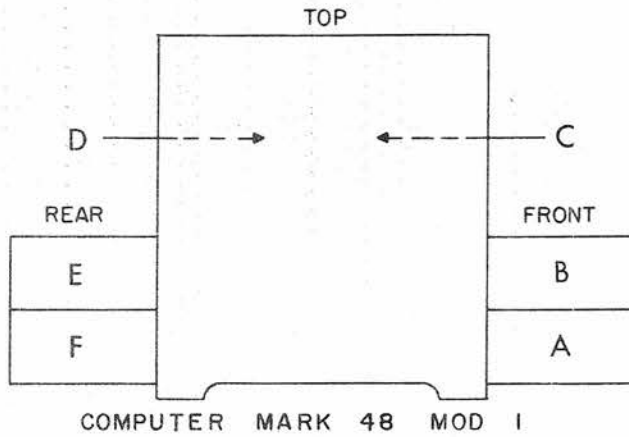

Figure 60. Key Diagram for Figures 61 through 66

ZA 4102		ZA 4107
ZB 4102		ZB 4106
ZA 4103		ZA 4106
ZB 4103		ZB 4105
ZB 4104		ZA 4105
		ZA 4104

Figure 61. Electronic Section, Front Drawer - Front View  
(Section A, Figure 60)

ZB4107		ZA4112
		ZB4112
ZA4108		
		ZA4109
ZB4108		
		ZB4109
ZB4110		
		ZA4110

Figure 62. Electronic Section, Front Drawer - Rear View  
(Section B, Figure 60)

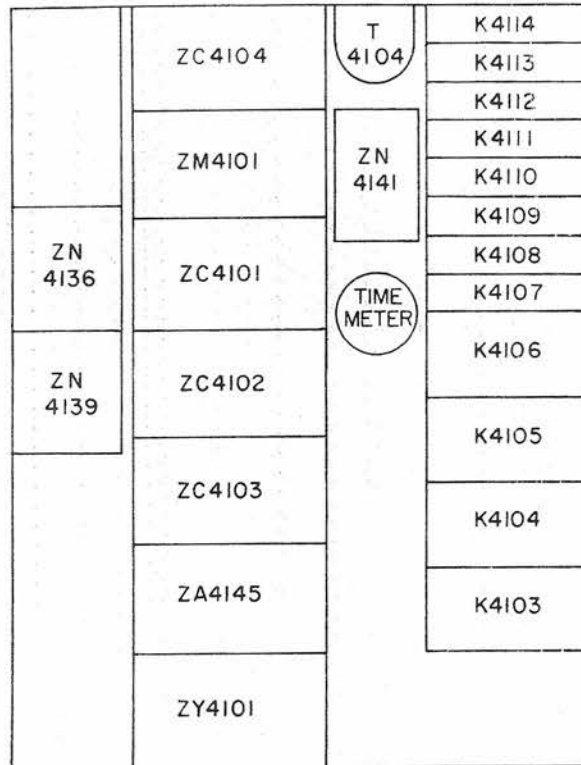

Figure 63. Electronic Section, Center Wall - Front View  
(Section C, Figure 60)

ZN 4337	ZN 4301	ZN 4335	ZN 4307	ZN 4300	ZN 4338				
	ZN 4314	ZN 4315	ZN 4329	ZN 4330					
						ZN 4303	ZN 4304	ZN 4308	ZN 4342
						T 4103	ZN 4310	ZN 4311	
							ZN 4325	ZN 4327	
						L 4103	ZN 4331	ZN 4332	
							ZN 4333	ZN 4334	

Figure 64. Electronic Section, Center Wall - Rear View  
(Section D, Figure 60)

ZA 4316		ZB430I
ZA4325		
ZA4327		ZA430I
ZA4329		
ZA4331		ZB4300
ZA4333		
ZA4335		
ZA4337		ZA4300
ZA4339		
ZA4341		
ZA4342		

Figure 65. Electronic Section, Rear Drawer - Rear View  
(Section E, Figure 60)

ZA4311	ZB4316
ZB4311	ZB4315
ZA4313	ZA4315
ZB4313	ZB4314
ZA4314	

Figure 66. Electronic Section, Rear Drawer - Front View  
(Section F, Figure 60)

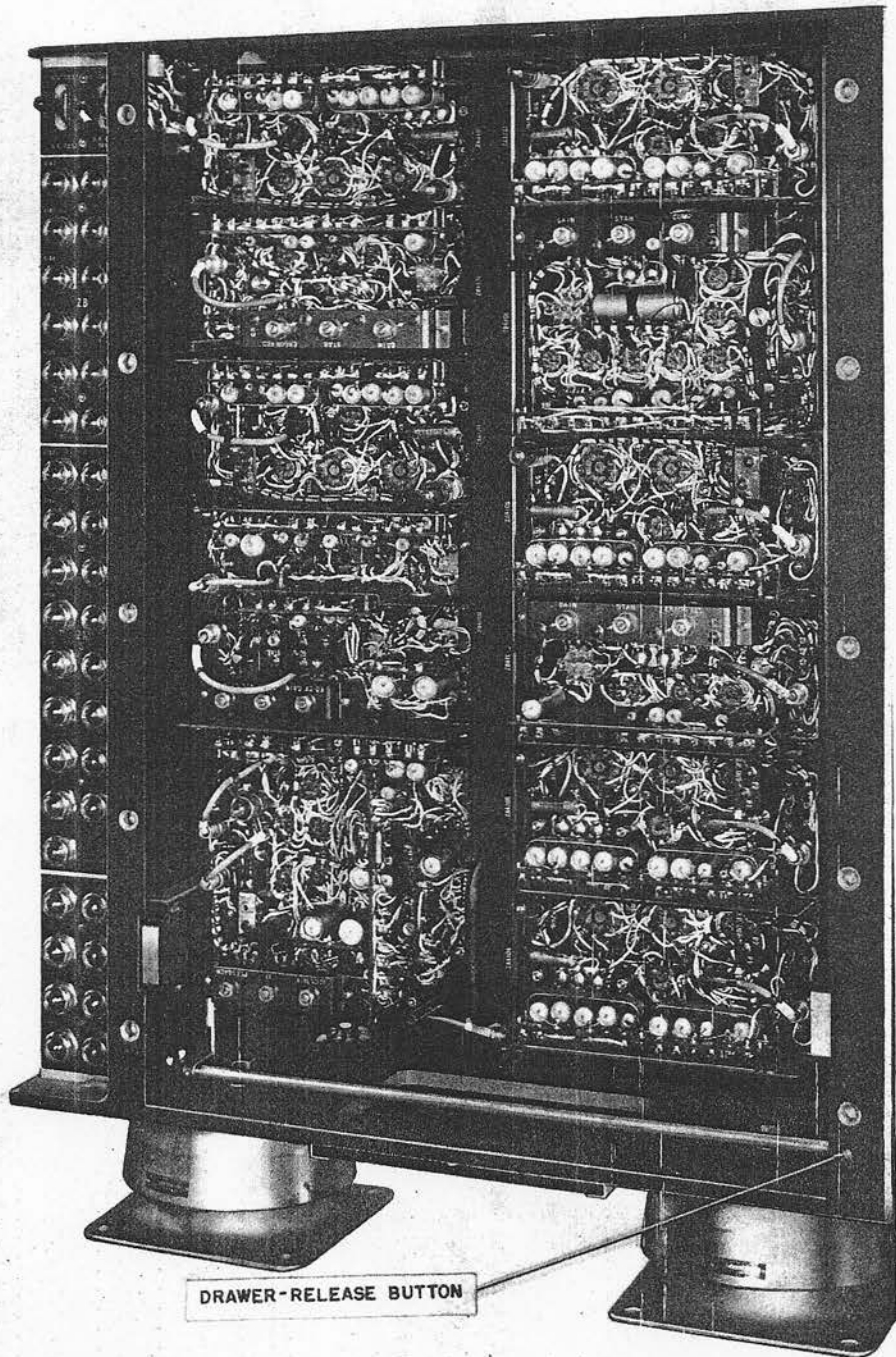

Figure 67. Front Electronic Section, Cover No. 4 Removed

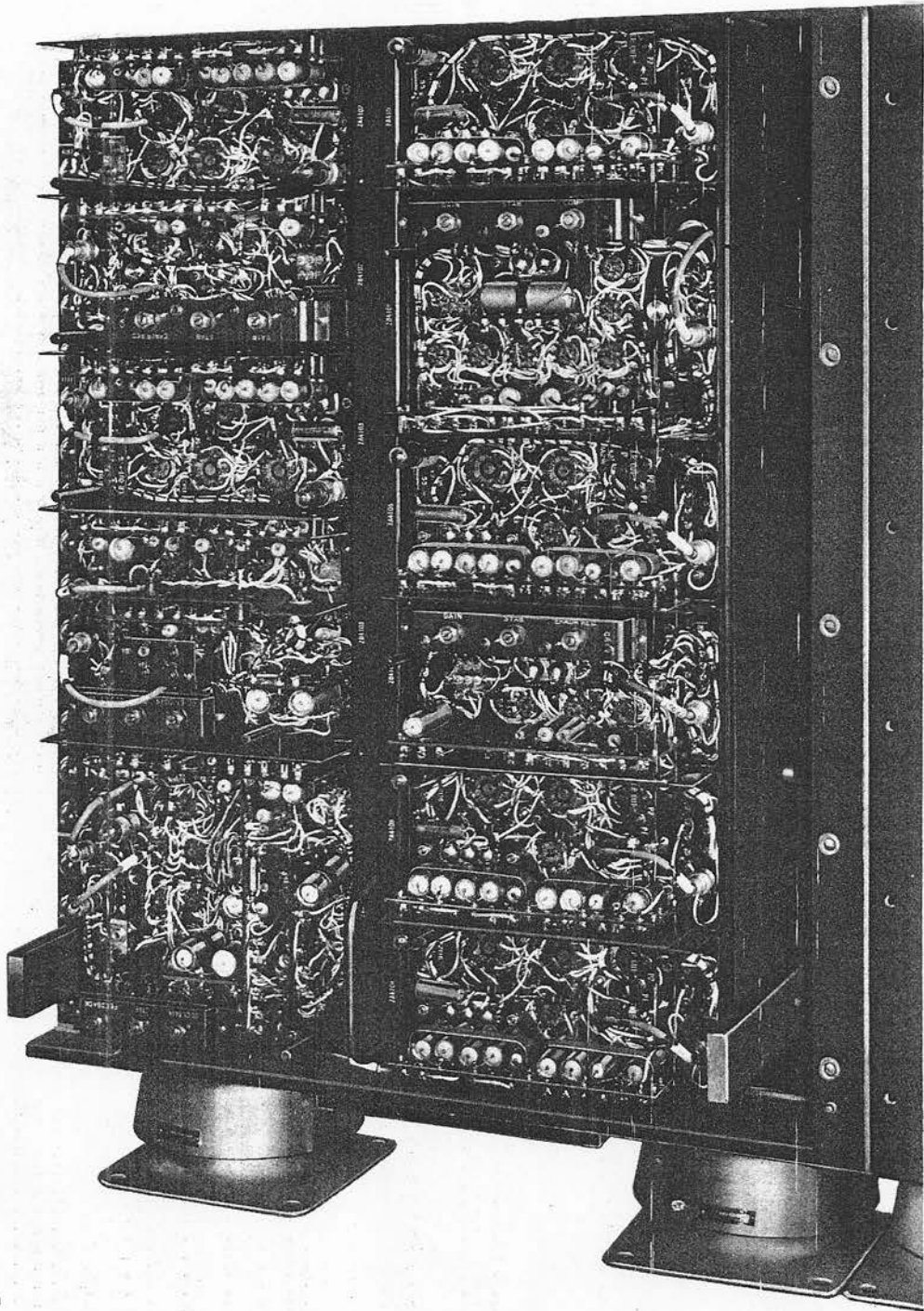

Figure 68. Front Drawer Pulled Out

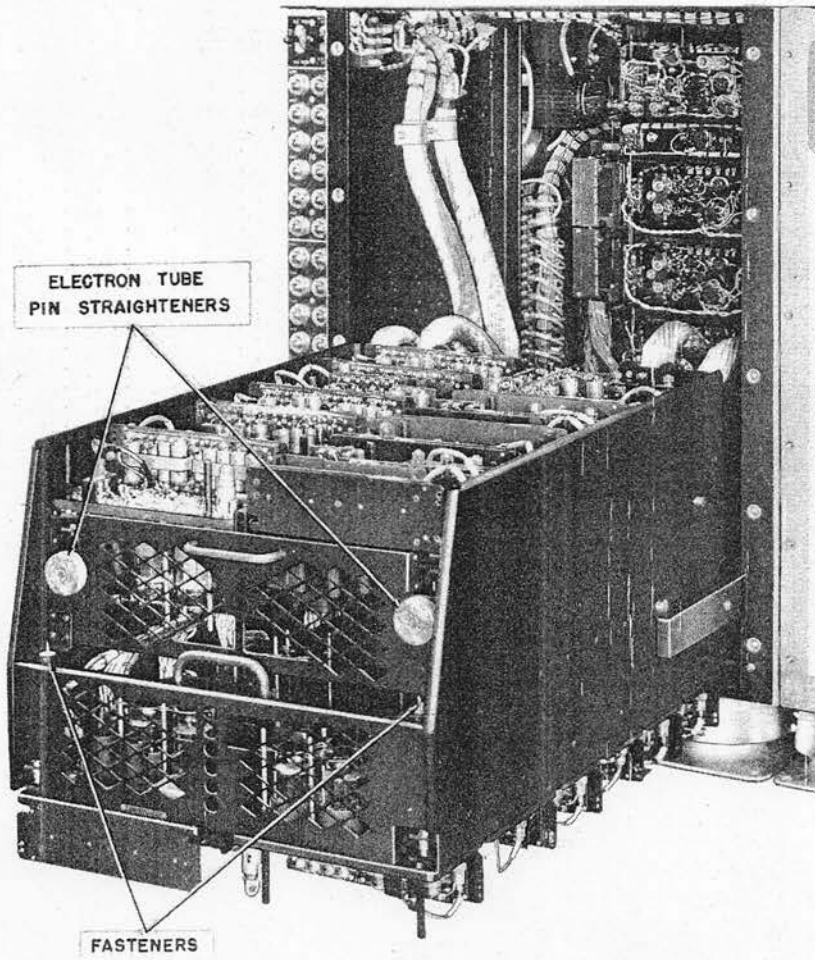

Figure 69. Front Drawer Out, Baskets Swung Down

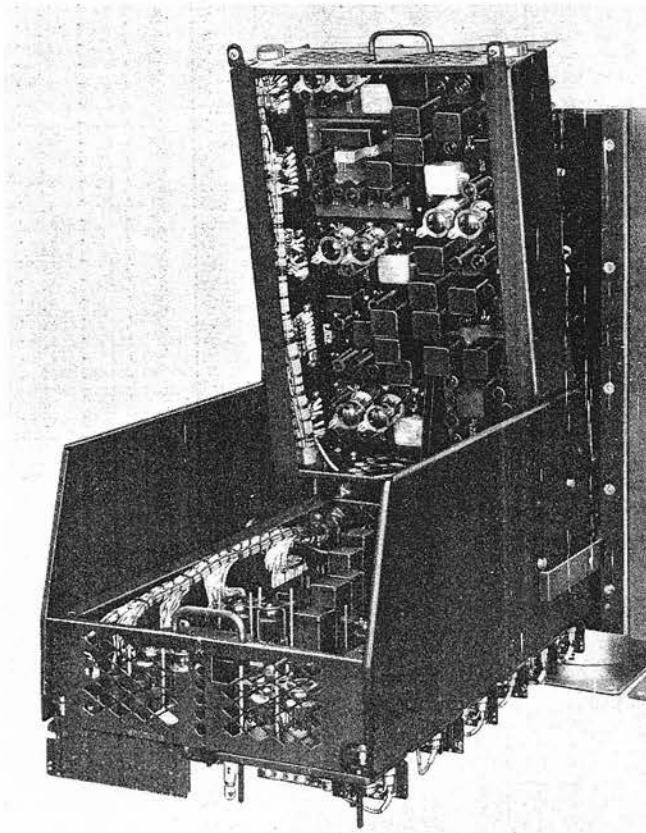

Figure 70 Front Drawer Out, Baskets Opened

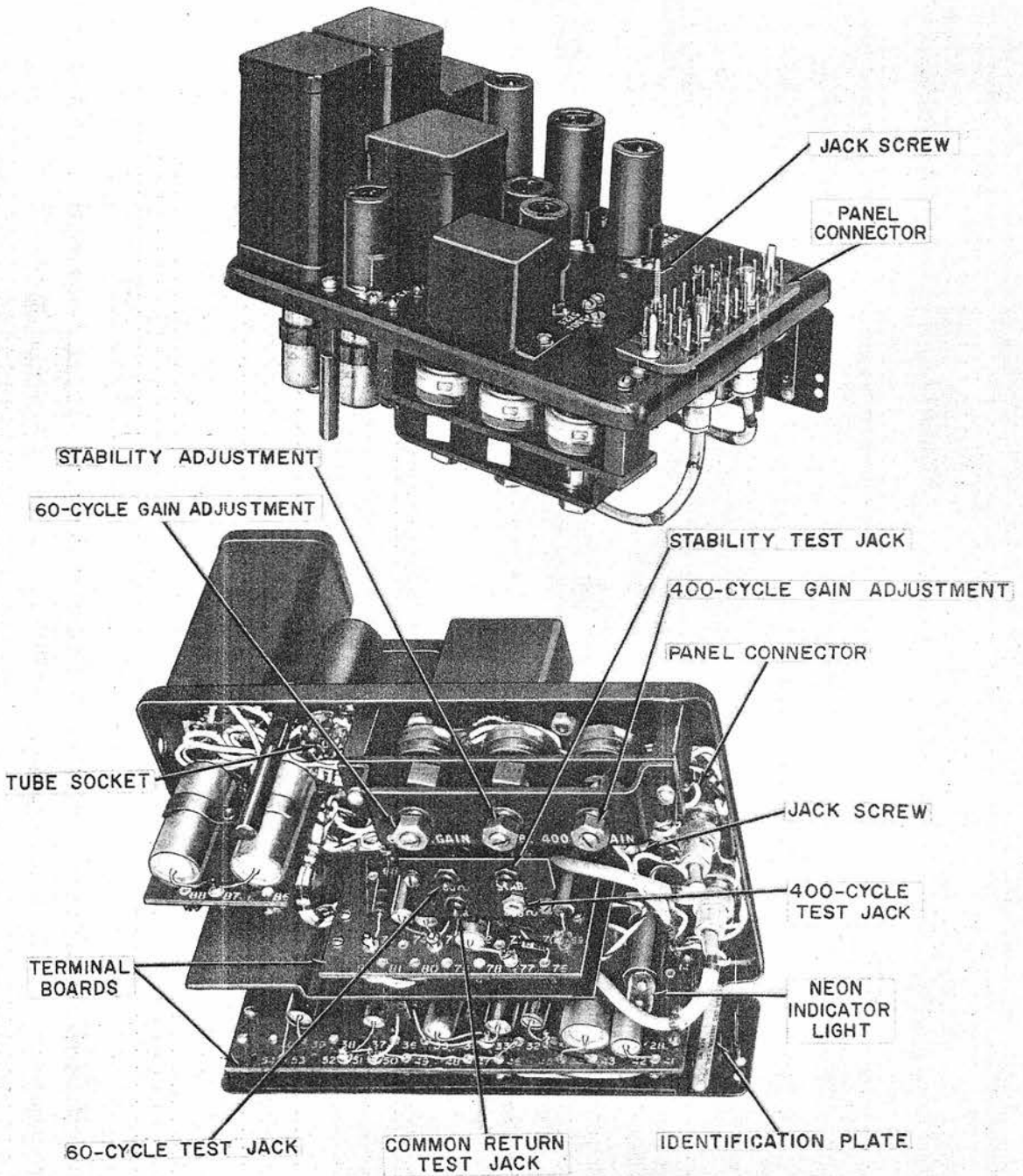

Figure 71. Typical Electronic Element of Computer Mk 48 Mod 1

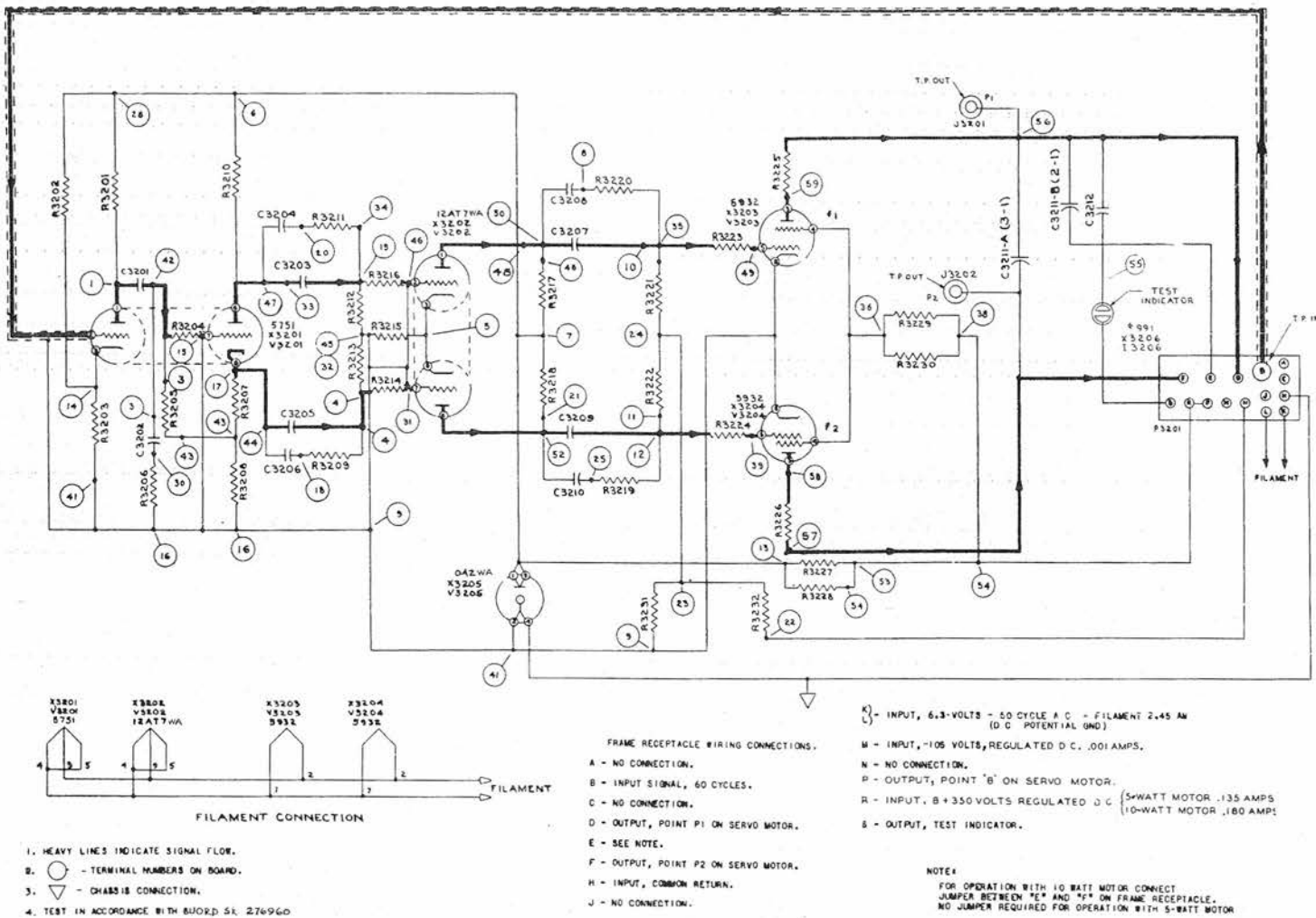

Figure 72. Servo Amplifier, 60-cycles, Schematic Diagram  
(Unit 3201)

Table 40

## UNIT 3201 - RESISTANCE AND VOLTAGE TESTS

BuOrd Dwg 980405

## Resistance Tests

Terminals	Normal	Minimum	Maximum
1	530.6K	503K	556K
2	Infinite	---	---
3	1.02M	972K	1.08M
4	470K	423K	517K
5	390	370	410
6	100.5K	95K	105.5K
7	100.5K	95K	105.5K
8	551K	499K	602K
9	0	0	0
10	81K	76.9K	85.1K
11	81K	76.9K	85.1K
12	81K	76.9K	85.1K
13	100.5K	95K	105.5K
14	560	532	588
15	1.49M	1.39M	1.59M
16	0	0	0
17	28.3K	26.9K	29.5K
18	1.47M	1.32M	1.62M
19	470K	423K	417K
20	470K	666K	814K
21	122.5K	115K	128.7K
22	122K	106.4K	117.6K
23	30K	28.5K	31.5K
24	30K	28.5K	31.5K
25	551K	499K	602K
28	100.5K	95K	105.5K
29	Infinite	---	---
30	100K	90K	110K
31	940K	886K	1.03K
32	0	0	0
33	130.5K	123K	137K
34	470K	423K	517K
35	81K	76.9K	85.1K
36	121.2K	114.7K	127.3K
38	115.5K	109.3K	120.3K
39	81.1K	77K	85.2K
41	0	0	0
42	1.03M	972K	1.08M
43	24K	22.8K	25.2K
44	28.3K	26.9K	29.5K
45	0	0	0
46	940K	886K	1.03M
47	130.5K	123K	137K
48	122.5K	115.9K	128.6K
49	81.1K	77K	85.2K

Table 40 (Cont'd)  
UNIT 3201 - RESISTANCE AND VOLTAGE TESTS

BuOrd Dwg 980405

## Resistance Tests

Terminals	Normal	Minimum	Maximum
50	122.5K	115.9K	128.6K
52	122.5K	115.9K	128.6K
53	115.5K	109.3K	120.3K
54	115.5K	109.3K	120.3K
55 to 56	56	50.4	61.6
57 to 58	56	50.4	61.6

## DC Voltage Tests

Terminal	Volts	Terminal	Volts
1	+75	31	0
2	+75	32	0
4	0	33	+137
5	0	34	0
6	+148	35	-27
7	+148	36	+275
8	-19.5	38	+350
9	0	39	-27.5
10	-27.5	41	0
11	-27.5	43	+7
13	+148	44	+9
14	+0.89	46	0
15	0	47	+137
16	0	49	-27.5
17	+9	50	+108.5
18	0	52	+105
19	0	53	+350
20	0	54	+350
21	+105	55	+320*
22	-105	55	+285**
23	-28	56	+315*
24	-28	56	+280**
25	-18.6	57	+320**
28	+148	57	+285**
29	+7	58	+315*
30	0	58	+280**

\*For 10-watt servo motor.

\*\*For 5-watt servo motor.

Voltage tolerance  $\pm 20$  per cent. Measurements made with input grid grounded to chassis.

Table 41  
UNIT 3201 - PARTS LIST

SYMBOL	DRAWING NO	PC NO	NOMENCLATURE	VALUE	RATING	TOL	NO REQ
X3206	1000448		SOCKET				1
X3205	12-Z-7510	113	SOCKET, TUBE; 7 PIN JAN TYPE TS102P01				1
X3204	12-Z-7510	117	SOCKET, TUBE; 8 PIN JAN TYPE TS101P02				2
X3202	12-Z-7510	114	SOCKET, TUBE; 9 PIN JAN TYPE TS103P01				2
V3205	16-T-52001	3	TUBE, ELECTRON; 0A2WA				1
V3204	12-Z-13005	608	TUBE, ELECTRON; 5932				2
V3202	16-T-58240	14	TUBE, ELECTRON; 12ATTWA				1
V3201	12-Z-13005	574	TUBE, ELECTRON; 5751				1
I3206	16-T-69910		LAMP, NEON GLOW; TYPE JAN-991				1
P3201	12-Z-7113	6391	CONNECTOR, PLUG; 14 LUG 1 COAX. CONTACT; MTG STUDS 2.688" C/C				1
J3202	12-Z-7113	3001	CONNECTOR, RECEPT; BR, SIL PL RD NYLON INSUL WITH MTG NUT				2
R3232	12-Z-13111	296	RESISTOR, FIXED COMPOSITION .406 LG X .175 DIA.	82 K	1/2 WATT	+5%	1
R3231	12-Z-13111	255	RESISTOR, FIXED COMPOSITION .406 LG X .175 DIA.	30 K	1/2 WATT	+5%	1
R3230	12-Z-13111	708	RESISTOR, FIXED COMPOSITION .750 LG X .370 DIA.	12 K	2 WATT	+5%	1
R3229	12-Z-13111	707	RESISTOR, FIXED COMPOSITION .750 LG X .370 DIA.	11 K	2 WATT	+5%	1
R3228	12-Z-13111	717	RESISTOR, FIXED COMPOSITION .750 LG X .370 DIA.	30 K	2 WATT	+5%	2
R3226	12-Z-13111	428	RESISTOR, FIXED COMPOSITION .750 LG X .280 DIA.	56 Ω	1 WATT	+10%	2
R3224	12-Z-13111	198	RESISTOR, FIXED COMPOSITION .406 LG X .175 DIA.	100 Ω	1/2 WATT	+10%	2
R3223	12-Z-13111	261	RESISTOR, FIXED COMPOSITION .406 LG X .175 DIA.	51 K	1/2 WATT	+5%	2
R3220	12-Z-13111	358	RESISTOR, FIXED COMPOSITION .406 LG X .175 DIA.	0.47 M	1/2 WATT	+10%	1
R3219	12-Z-13111	358	RESISTOR, FIXED COMPOSITION .406 LG X .175 DIA.	0.47 M	1/2 WATT	+10%	1
R3218	12-Z-13111	252	RESISTOR, FIXED COMPOSITION .406 LG X .175 DIA.	22 K	1/2 WATT	+5%	2
R3216	12-Z-13111	358	RESISTOR, FIXED COMPOSITION .406 LG X .175 DIA.	0.47 M	1/2 WATT	+10%	1
R3215	12-Z-13111	210	RESISTOR, FIXED COMPOSITION .406 LG X .175 DIA.	390 Ω	1/2 WATT	+5%	1
R3214	12-Z-13111	358	RESISTOR, FIXED COMPOSITION .406 LG X .175 DIA.	0.47 M	1/2 WATT	+10%	2
R3213	12-Z-13111	358	RESISTOR, FIXED COMPOSITION .406 LG X .175 DIA.	0.47 M	1/2 WATT	+10%	1
R3212	12-Z-13111	355	RESISTOR, FIXED COMPOSITION .406 LG X .175 DIA.	0.27 M	1/2 WATT	+10%	1
R3210	12-Z-13111	255	RESISTOR, FIXED COMPOSITION .406 LG X .175 DIA.	30 K	1/2 WATT	+5%	1
R3209	12-Z-13111	362	RESISTOR, FIXED COMPOSITION .406 LG X .175 DIA.	1.0 M	1/2 WATT	+10%	1
R3208	12-Z-13111	253	RESISTOR, FIXED COMPOSITION .406 LG X .175 DIA.	24 K	1/2 WATT	+5%	1
R3207	12-Z-13111	235	RESISTOR, FIXED COMPOSITION .406 LG X .175 DIA.	4.3 K	1/2 WATT	+5%	1
R3206	12-Z-13111	350	RESISTOR, FIXED COMPOSITION .406 LG X .175 DIA.	0.1 M	1/2 WATT	+10%	1
R3205	12-Z-13111	322	RESISTOR, FIXED COMPOSITION .406 LG X .175 DIA.	1.0 M	1/2 WATT	+5%	1
R3204	12-Z-13111	358	RESISTOR, FIXED COMPOSITION .406 LG X .175 DIA.	0.47 M	1/2 WATT	+10%	1
R3203	12-Z-13111	214	RESISTOR, FIXED COMPOSITION .406 LG X .175 DIA.	560 Ω	1/2 WATT	+5%	1
R3202	12-Z-13111	298	RESISTOR, FIXED COMPOSITION .406 LG X .175 DIA.	0.1 M	1/2 WATT	+5%	1
R3201	12-Z-13111	313	RESISTOR, FIXED COMPOSITION .406 LG X .175 DIA.	0.43 M	1/2 WATT	+5%	1
C3211-A C3211-B	12-Z-13100	2177	CAPACITOR, FIXED PAPER JAN TYPE AP55H4FG254V	0.25 MFD 0.25 MFD	1000 WVDC	+20% -10%	1
C3212	12-Z-13100	9624	CAPACITOR, FIXED PAPER 1-1/8 LG X .400 DIA.	0.033 MFD	600 WVDC	+20%	1
C3210 C3209 C3208 C3207 C3206	16-C-46201	1001	CAPACITOR, FIXED PAPER 1-3/8 LG X .562 DIA.	.22 MFD	300 WVDC	+20%	5
C3205	12-Z-13100	9539	CAPACITOR, FIXED PAPER 7/8 LG X .400 DIA.	.047 MFD	300 WVDC	+20%	1
C3204	16-C-46201	1001	CAPACITOR, FIXED PAPER 1-3/8 LG X .562 DIA.	.22 MFD	300 WVDC	+20%	1
C3203	12-Z-13100	9539	CAPACITOR, FIXED PAPER 7/8 LG X .400 DIA.	.047 MFD	300 WVDC	+20%	1
C3202	12-Z-13100	9503	CAPACITOR, FIXED PAPER 3/4 LG X .235 DIA.	.0022 MFD	300 WVDC	+10%	1
C3201	16-C-46201	1001	CAPACITOR, FIXED PAPER 1-3/8 LG X .562 DIA.	.22 MFD	300 WVDC	+20%	1

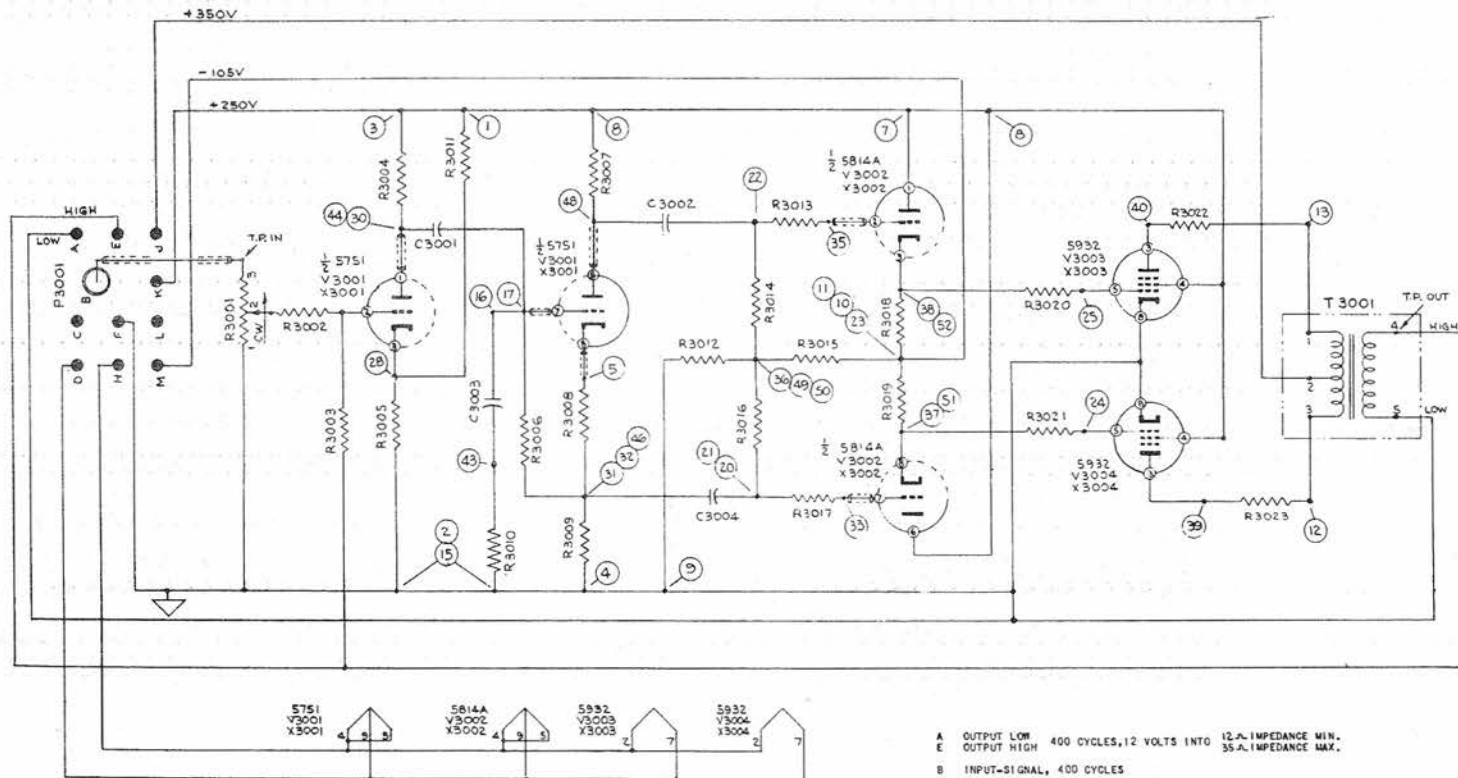

## NOTES:

1. = TERMINAL POINTS ON TERMINAL.
2. = CHASSIS CONNECTION.
3. = SHIELDED WIRE.
4. TEST IN ACCORDANCE WITH BUQRD 5K 285423
5. ALL SHIELDED WIRES GROUND AT ONE END.

- A OUTPUT LOW 400 CYCLES, 12 VOLTS INTO 12 $\Omega$  IMPEDANCE MIN.  
 E OUTPUT HIGH 35 $\Omega$  IMPEDANCE MAX.
- B INPUT-SIGNAL, 400 CYCLES
- C NO CONNECTION
- D H INPUT - 6.3-VOLT FILAMENT, 60-CYCLES, 2.3 AMPS (D.C. POTENTIAL, GND)
- F INPUT - COMMON RETURN
- J INPUT - +350 VOLTS D C .115 AMPS.
- K INPUT - +250 VOLTS REGULATED D C .024 AMPS
- L NO CONNECTION
- M INPUT - -150 VOLTS, .005 AMPS.

Figure 73. Tuning Fork Amplifier, 400-cycles, Schematic Diagram  
 (Unit 3402)

Table 42

## UNIT 3402 - RESISTANCE AND VOLTAGE TESTS

BuOrd Dwg 1372170

## Resistance Tests

Remove all tubes from sockets.

Terminals	Normal	Minimum	Maximum
1, 3	120K	110K	130K
2, 4	0	0	0
5	106K	95K	117K
6	No connection		
7, 8	120K	110K	130K
9	0	0	0
10, 11	66K	65K	67K
12, 13	Infinite	Infinite	Infinite
14	No connection	---	---
15	0	0	0
16, 17	1.1M	1M	1.2M
18, 19	No connection	---	---
20, 21, 22	492K	440K	530K
23	66K	65K	67K
24, 25	88K	86K	90K
26, 27	No connection	---	---
28	510	484	536
29	Infinite	Infinite	Infinite
30	510K	480K	540K
31, 32	100K	90K	110K
33, 35	.962M	.86M	1.06M
34	No connection	---	---
36	22K	21.8K	22.2K
37, 38	88K	86K	90K
39, 40	Infinite	Infinite	Infinite
43	12K	11K	13K
44	510K	480K	540K
45, 47	No connection	---	---
46	100K	90K	110K
48	220K	210K	230K
49, 50	22K	21.8K	22.2K
51, 52	88K	86K	90K
TOP OF POT	500K	450K	550K

Table 42 (Cont'd)  
UNIT 3402 - RESISTANCE AND VOLTAGE TESTS

BuOrd Dwg 1372170

Resistance Tests

Turn all potentiometers counterclockwise.

Terminals	Volts $\pm 20\%$	Terminal	Volts $\pm 20\%$
5 to 46	2.3	38 to 49	15
10, 11, 23	-105	12, 13, 39, 40	350
24, 25	-22	1, 3, 7, 8	250
33, 35	-19		
37 to 49	15	37, 38	-22

Table 43  
UNIT 3402 - PARTS LIST

SYMBOL	DRAWING NO	PC NO	NOMENCLATURE	VALUE	RATING	TOL	NO REQ
X3004 X3003	12-Z-7510	117	SOCKET				2
X3002 X3001	12-Z-7510	114	SOCKET				2
V3004 V3003	12-Z-13005	608	TUBE, ELECTRON; 5932				2
V3002	12-Z-13005	652	TUBE ELECTRON; 5814A, MINIATURE (RUGGED); 9 PIN				1
V3001	12-Z-13005	574	TUBE ELECTRON; 5751 MINIATURE VOLTAGE AMPLIFIER; 9 PIN				1
T3001	ORD, SK, 276518		TRANSFORMER (596439)				1
P3001	12-Z-7113	6306	CONNECTOR, PLUG; PNL. TY. 10 LUGS ONE COAX; 2 5/16 LG. X 1/8				1
R3023 R3022	12-Z-13111	419	RESISTOR, FIXED; COMPOSITION .750 LG. X .280 DIA.	10 OHMS	1 WATT	+10%	2
R3021 R3020	12-Z-13111	427	RESISTOR, FIXED; COMPOSITION .750 LG. X .280 DIA.	47 OHMS	1 WATT	+10%	2
R3019 R3018	12-Z-13111	482	RESISTOR, FIXED; COMPOSITION .750 LG. X .280 DIA.	22 K	1 WATT	+5%	2
R3017 R3016	12-Z-13111	358	RESISTOR, FIXED; COMPOSITION .406 LG. X .175 DIA.	470K	1/2 WATT	+10%	2
R3015	12-Z-13110	7392	RESISTOR, FIXED; COMPOSITION 5/8 LG. X .203 DIA.	44 K	1/2 WATT	+1%	1
R3014 R3013	12-Z-13111	358	RESISTOR, FIXED; COMPOSITION .406 LG. X .175 DIA.	470K	1/2 WATT	+10%	2
R3012	12-Z-13110	7382	RESISTOR, FIXED; COMPOSITION 5/8 LG. X .203 DIA.	22 K	1/2 WATT	+1%	1
R3011	12-Z-13111	531	RESISTOR, FIXED; COMPOSITION .750 LG. X .280 DIA.	120 K	1 WATT	+5%	1
R3010	12-Z-13111	222	RESISTOR, FIXED; COMPOSITION .406 LG. X .175 DIA.	12 K	1/2 WATT	+5%	1
R3009	12-Z-13111	350	RESISTOR, FIXED; COMPOSITION .406 LG. X .175 DIA.	100K	1/2 WATT	+10%	1
R3008	12-Z-13110	7371	RESISTOR, FIXED; COMPOSITION 5/8 X .203 DIA.	5.7K	1/2 WATT	+1%	1
R3007	12-Z-13111	298	RESISTOR, FIXED; COMPOSITION .406 LG. X .175 DIA.	100K	1/2 WATT	+5%	1
R3006	12-Z-13111	362	RESISTOR, FIXED; COMPOSITION .406 LG. X .175 DIA.	1 MEG	1/2 WATT	+10%	1
R3005	12-Z-13111	213	RESISTOR, FIXED; COMPOSITION .406 LG. X .175 DIA.	510 OHMS	1/2 WATT	+5%	1
R3004	12-Z-13111	312	RESISTOR, FIXED; COMPOSITION .406 LG. X .175 DIA.	390K	1/2 WATT	+5%	1
R3003	12-Z-13111	322	RESISTOR, FIXED; COMPOSITION .406 LG. X .175 DIA.	1 M	1/2 WATT	+5%	1
R3002	12-Z-13111	314	RESISTOR, FIXED; COMPOSITION .406 LG. X .175 DIA.	470K	1/2 WATT	+5%	1
R3001	16-R-88179	4680	RESISTOR, VARIABLE COMP. LIN. TAPER 1 1/16 DIA. X 9/16D. RD. SHAFT, SCR. DR. SLT. 1/4 DIA. X 5/8 LG. BUSHING 3/8-32 TH'D NEF-2	500K	2 WATT	+10%	1
C3004	12-Z-13100	9539	CAPACITOR, FIXED PAPER DIELEC. SUBMINIATURE 7/8 LG. X .400 DIA.	.047 MFD	300 WVDC	+20%	1
C3003	16-C-30663	3292	CAPACITOR, FIXED MICA DIELEC. MOLDED 51/64 X 51/64 X 9/32	.00075MFD	500 WVDC	+5%	1
C3002 C3001	12-Z-13100	9539	CAPACITOR, FIXED PAPER DIELEC. SUBMINIATURE 7/8 LG. X .400 DIA.	.047 MFD	300 WVDC	+20%	2

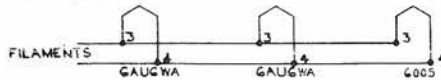
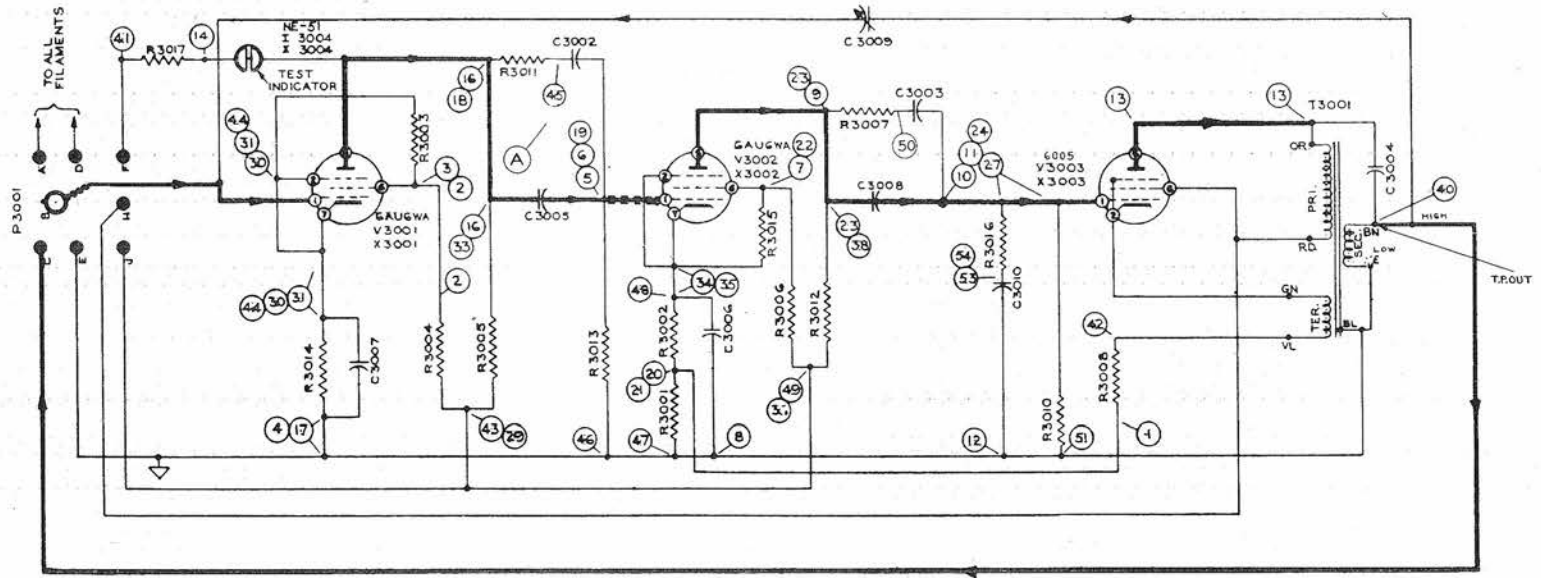

## FRAME RECEPTACLE WIRE CONNECTIONS.

- a) INPUT 6.3 VOLT-FILAMENT, 60% A.C., 1.05 AMPS. (D.C. POTENTIAL-GND).  
 b INPUT SIGNAL 400 ~  
 c OUTPUT SIGNAL 12 VOLTS, 400 ~ INTO 500-OHM LOAD.  
 e INPUT, COMMON RETURN.  
 f OUTPUT, TEST INDICATOR.  
 h INPUT B+250 VOLTS REGULATED D.C., .087 AMPS.  
 j INPUT B+250 VOLTS REGULATED D.C., .007 AMPS.

## NOTES:

1. ○ = TERMINAL POINTS ON TERMINAL BOARD.  
 2. ⚡ = CHASSIS CONNECTION.  
 3. SIGNAL FLOW INDICATED BY HEAVY LINES.  
 4. TEST IN ACCORDANCE WITH BUORD SK 27695B

Figure 74. Single-Channel Amplifier, Schematic Diagram  
(Unit 3001)

Table 44

## UNIT 3001 - RESISTANCE AND VOLTAGE TESTS

BuOrd Dwg 980431

## Resistance Tests

Terminals	Normal	Minimum	Maximum
1	1.8	1.7	1.9
2, 3	20.3K	18.3K	22.3K
4	0	0	0
5, 6	1M	950K	1.05M
7	20.3K	18.3K	22.3K
8	0	0	0
9	211K	193K	229K
10, 11	560K	504K	616K
12	0	0	0
13, 14	Infinite	---	---
16	211K	193K	229K
17	0	0	0
18	211K	193K	229K
19	1M	950K	1.05M
20, 21	1.8	1.7	1.9
22	20.3K	18.3K	22.3K
23	211K	193K	229K
24	560K	504K	616K
27	560K	504K	616K

Table 44 (Cont'd)

## UNIT 3001 - RESISTANCE AND VOLTAGE TESTS

BuOrd Dwg 980431

## Resistance Tests

Terminals	Normal	Minimum	Maximum
29	61. 2K	55. 1K	67. 3K
30, 31	468	444	492
33	211K	193K	229K
34, 35	332	315	349
36	61. 2K	55. 1K	67. 3K
38	211K	193K	229K
40	16	15	17
41	Infinite	---	---
42	622	587	653
43	61. 2K	55. 1K	67. 3K
44	468	444	492
45	1. 41M	1. 33M	1. 49M
46, 47	0	0	0
48	332	315	349
49	61. 2K	55. 1K	67. 3K
50	2. 41M	2. 28M	2. 54M
51	0	0	0
53	599K	541K	657K
54	599K	541K	657K

Table 44 (Cont'd)

## UNIT 3001 - RESISTANCE AND VOLTAGE TESTS

BuOrd Dwg 980431

## Resistance Tests

Terminals	Normal	Minimum	Maximum
13 to P3001-H	255	242	268
42 to X3003-2	19	18	20
41 to 14	75K	71.2K	78.3K

## DC Voltage Tests

Terminal	Volts	Terminal	Volts
1	+0.05	16	+180
2	+44	29	+250
4	0	31	+1.1
5	0	34	+0.85
7	+40	37	+120
9	+170	40	0
10	0	41	+87.5
13	+243	42	+16

Voltage tolerance  $\pm 20$  per cent. Measurements made with input grid grounded to chassis.

Table 45  
UNIT 3001 - PARTS LIST

SYMBOL	DRAWING NO	PC NO	NOMENCLATURE	VALUE	RATING	TOL	NO REQ
I3004	17-L-6806	130	LAMP, NEON GLOW TYPE MAZA CAT. NO. DR EQUAL NES1				1
X3004	12-Z-7499	17	SOCKET				1
X3003	12-Z-7510	112	SOCKET, ELECTRON TUBE, 7 PIN BE.CU.SI.PLATED HOT TIN DIPPED				1
X3002	12-Z-7510	113	SOCKET, ELECTRON TUBE, 7 PIN JAN TYPE TS102P01				2
V3003	12-Z-13005	620	TUBE, ELECTRON, JAN-6005/GAQS5V MINIATURE POWER AMPL. REG.				1
V3002	16-T-56203	53	TUBE, ELECTRON, JAN-6416WA, 7 PIN MINIATURE BUTTON BASE				2
T3001	SK 137317		TRANSFORMER (595596)				1
P3001	12-Z-7113	6331	CONNECTOR, PLUG 7 LUG, 1 COAX. CONTACT, MTG. STUDS, 1.562 C/C				1
R3017	12-Z-13111	295	RESISTOR, FIXED COMPOSITION .175 DIA. X .406 LONG	75 K	1/2 WATT	± 5%	1
R3016	12-Z-13111	258	RESISTOR, FIXED COMPOSITION .175 DIA. X .406 LONG	39K	1/2 WATT	± 5%	1
R3015	12-Z-13111	287	RESISTOR, FIXED COMPOSITION .175 DIA. X .406 LONG	22 K	1/2 WATT	± 10%	1
R3014	12-Z-13110	837	RESISTOR, FIXED WIRE WOUND 15/64 DIA. X 21/32 LONG	470 Ω	1/2 WATT	± 5%	1
R3013	12-Z-13111	322	RESISTOR, FIXED COMPOSITION .175 DIA. X .406 LONG	1.0 M	1/2 WATT	± 5%	1
R3012	12-Z-13111	352	RESISTOR, FIXED COMPOSITION .175 DIA. X .406 LONG	0.15 M	1/2 WATT	± 10%	1
R3011	12-Z-13111	324	RESISTOR, FIXED COMPOSITION .175 DIA. X .406 LONG	1.2 M	1/2 WATT	± 5%	1
R3010	12-Z-13111	359	RESISTOR, FIXED COMPOSITION .175 DIA. X .406 LONG	0.56 M	1/2 WATT	± 10%	1
R3008	12-Z-13110	904	RESISTOR, FIXED WIRE WOUND 15/64 DIA. X 19/32 LONG	620 Ω	1 WATT	± 5%	1
R3007	12-Z-13111	330	RESISTOR, FIXED COMPOSITION .175 DIA. X .406 LONG	2.2 M	1/2 WATT	± 5%	1
R3006	12-Z-13111	585	RESISTOR, FIXED COMPOSITION .28 DIA. X .750 LONG	0.1 M	1 WATT	± 10%	1
R3005	12-Z-13111	352	RESISTOR, FIXED COMPOSITION .175 DIA. X .406 LONG	0.15 M	1/2 WATT	± 10%	1
R3004	12-Z-13111	585	RESISTOR, FIXED COMPOSITION .28 DIA. X .750 LONG	0.1 M	1 WATT	± 10%	1
R3003	12-Z-13111	287	RESISTOR, FIXED COMPOSITION .175 DIA. X .406 LONG	22 K	1/2 WATT	± 10%	1
R3002	16-R-68373	1526	RESISTOR, FIXED WIRE WOUND 15/64 DIA. X 21/32 LONG	330 Ω	1/2 WATT	± 5%	1
R3001	12-Z-13110	799	RESISTOR, FIXED WIRE WOUND 15/64 DIA. X 21/32 LONG	1.8 Ω	1/2 WATT	± 5%	1
C3010	16-C-32720	7533	CAPACITOR, FIXED MICA, DIELEC. 53/64 X 53/64 X 11/32	5100 MMFD	500 WVDC	± 5%	1
C3009	16-C-63900	6761	CAPACITOR, VARIABLE, CERAMIC JAN TYPE CV11A070	1.5 TO 7 MMFD	500 WVDC	—	1
C3008	12-Z-13100	9547	CAPACITOR, FIXED PAPER, DIELEC. .312 DIA. 7/8 LONG	.01 MFD	300 WVDC	± 10%	1
C3007	16-C-32646	6813	CAPACITOR, FIXED MICA, DIELEC. 53/64 X 53/64 X 11/32	4700 MMFD	500 WVDC	± 10%	1
C3006	16-C-31908	1569	CAPACITOR, FIXED MICA, DIELEC. 53/64 X 53/64 X 9/32	2200 MMFD	500 WVDC	± 10%	1
C3005	12-Z-13100	9547	CAPACITOR, FIXED PAPER, DIELEC. .312 DIA. 7/8 LONG	.01 MFD	300 WVDC	± 10%	1
C3004	12-Z-13100	9587	CAPACITOR, FIXED PAPER, DIELEC. .400 DIA. 7/8 LONG	.051 MFD	300 WVDC	± 5%	1
C3003	12-Z-13100	9559	CAPACITOR, FIXED PAPER, DIELEC. .400 DIA. 1 3/8 LONG	0.1 MFD	300 WVDC	± 10%	2

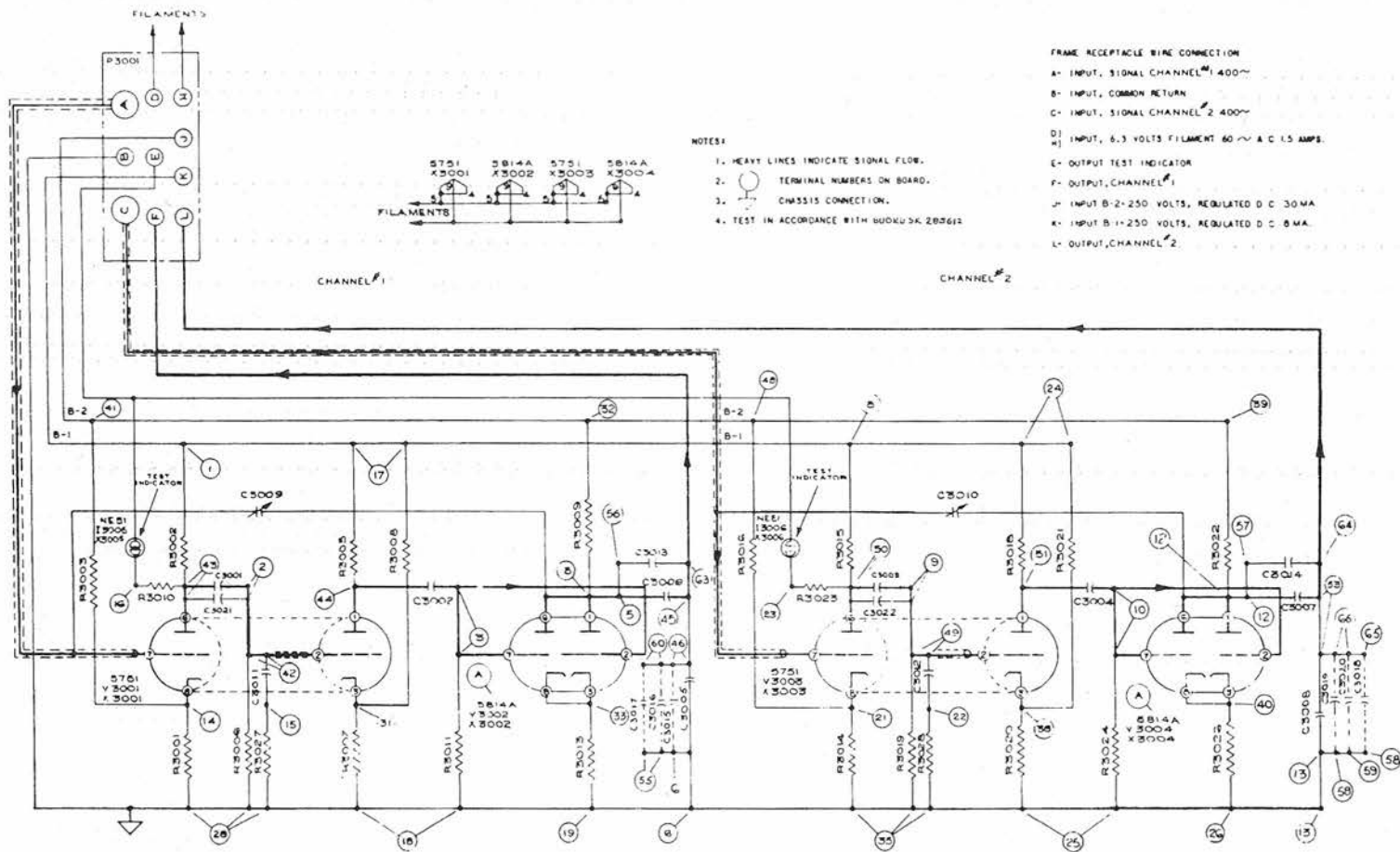

Figure 75. Computing Amplifier, Dual-Channel, Schematic Diagram (Unit 3012)

**Table 46**  
**UNIT 3012 - RESISTANCE AND VOLTAGE TESTS**

BuOrd Dwg 1371931

Resistance Tests

Terminals	Normal	Minimum	Maximum
2	2.4M	2.28M	2.52M
3	470K	423K	517K
6, 13, 18, 19, 25, 26, 28, 35	0		
8	53K	50.3K	55.7K
9	2.4M	2.28M	2.52M
10	470K	423K	517K
14	470	446	494
15	56K	53.2K	58.8K
21	470	446	494
22	56K	53.2K	58.8K
31	470	446	494
32	55K	52.2K	57.75K
33	560	532	588
38	470	446	494
40	560	532	588
42	2.4M	2.28M	2.52M
49	2.4M	2.28M	2.52M
56, 58, 59	0		
8, 17, 24 to 1	0		
37, 39, 48 to 41	0		
43, 44, 50, 51 to 1	470K	446K	494K
5, 12 to 41	5.6K	5.32K	5.88K
43 to 16	75K	71.25K	78.75K
50 to 23	75K	71.25K	78.75K

DC Voltage Tests

Terminals	Voltage	Terminal	Voltage
14, 21, 31, 38 33, 40	1.2 4.5	43, 44, 50, 51 55, 57	85 180

Table 47  
UNIT 3012 - PARTS LIST

SYMBOL	DESCRIPTION	VALUE	RATING	TOL	DRAWING NO	QUAN
X3006	SOCKET				1000447	2
X3005						
X3004						
X3003						
X3002						
X3001					12-Z-7510-114	4
I3005	LAMP NE-5I				17-L-6806-130	2
I3008						
V3004	TUBE(5814A)				12-Z-13005-652	1
V3003	TUBE(575I)				12-Z-13005-574	1
V3002	TUBE(5814A)				12-Z-13005-652	1
V3001	TUBE(575I)				12-Z-13005-574	1
P3001	CONNECTOR				12-Z-7113-6389	1
R3028	RESISTOR	56 K	$\frac{1}{2}$ WATT	$\pm 5\%$	12-Z-13111-292	1
R3027	RESISTOR	56 K	$\frac{1}{2}$ WATT	$\pm 5\%$	12-Z-13111-292	1
R3026	RESISTOR	560 $\Omega$	$\frac{1}{2}$ WATT	$\pm 5\%$	12-Z-13111-214	1
R3024	RESISTOR	470 K	$\frac{1}{2}$ WATT	$\pm 10\%$	12-Z-13111-358	1
R3023	RESISTOR	75 K	$\frac{1}{2}$ WATT	$\pm 5\%$	12-Z-13111-295	1
R3022	RESISTOR	5.6K	2 WATT	$\pm 5\%$	12-Z-13111-700	1
R3021	RESISTOR	110 K	1 WATT	$\pm 5\%$	12-Z-13111-530	1
R3020	RESISTOR	470 $\Omega$	$\frac{1}{2}$ WATT	$\pm 5\%$	12-Z-13111-212	1
R3019	RESISTOR	2.4 M	$\frac{1}{2}$ WATT	$\pm 5\%$	12-Z-13111-351	1
R3018	RESISTOR	470 K	$\frac{1}{2}$ WATT	$\pm 5\%$	12-Z-13111-314	1
R3016	RESISTOR	110 K	1 WATT	$\pm 5\%$	12-Z-13111-530	1
R3015	RESISTOR	470 K	$\frac{1}{2}$ WATT	$\pm 5\%$	12-Z-13111-314	1
R3014	RESISTOR	470 $\Omega$	$\frac{1}{2}$ WATT	$\pm 5\%$	12-Z-13111-212	1
R3013	RESISTOR	560 $\Omega$	$\frac{1}{2}$ WATT	$\pm 5\%$	12-Z-13111-214	1
R3011	RESISTOR	470 K	$\frac{1}{2}$ WATT	$\pm 10\%$	12-Z-13111-358	1
R3010	RESISTOR	75 K	$\frac{1}{2}$ WATT	$\pm 5\%$	12-Z-13111-295	1
R3009	RESISTOR	5.6K	2 WATT	$\pm 5\%$	12-Z-13111-700	1
R3008	RESISTOR	110 K	1 WATT	$\pm 5\%$	12-Z-13111-530	1
R3007	RESISTOR	470 $\Omega$	$\frac{1}{2}$ WATT	$\pm 5\%$	12-Z-13111-212	1
R3006	RESISTOR	2.4 M	$\frac{1}{2}$ WATT	$\pm 5\%$	12-Z-13111-351	1
R3005	RESISTOR	470 K	$\frac{1}{2}$ WATT	$\pm 5\%$	12-Z-13111-314	1
R3003	RESISTOR	110 K	1 WATT	$\pm 5\%$	12-Z-13111-530	1
R3002	RESISTOR	470 K	$\frac{1}{2}$ WATT	$\pm 5\%$	12-Z-13111-314	1
R3001	RESISTOR	470 $\Omega$	$\frac{1}{2}$ WATT	$\pm 5\%$	12-Z-13111-212	1
C3020				100 WVDC		
C3019				100 WVDC		
C3018				100 WVDC		
C3017				100 WVDC		
C3016				100 WVDC		
C3015				100 WVDC		
C3014	CAPACITOR	0.68 MFD	300 WVDC	$\pm 10\%$	12-Z-13100-9557	2
C3013						
C3012	CAPACITOR	.001 MFD	300 WVDC	$\pm 10\%$	12-Z-13100-9499	2
C3011						
C3010	CAPACITOR	9-16 MMF			51-128	2
C3009						
C3008	CAPACITOR		100 WVDC			
C3007	CAPACITOR	.1 MFD	300 WVDC	$\pm 10\%$	12-Z-13100-9559	2
C3006						
C3005	CAPACITOR		100 WVDC			
C3022						
C3021						
C3004	CAPACITOR	.1 MFD	300 WVDC	$\pm 10\%$	12-Z-13100-9559	6
C3003						
C3002						
C3001						

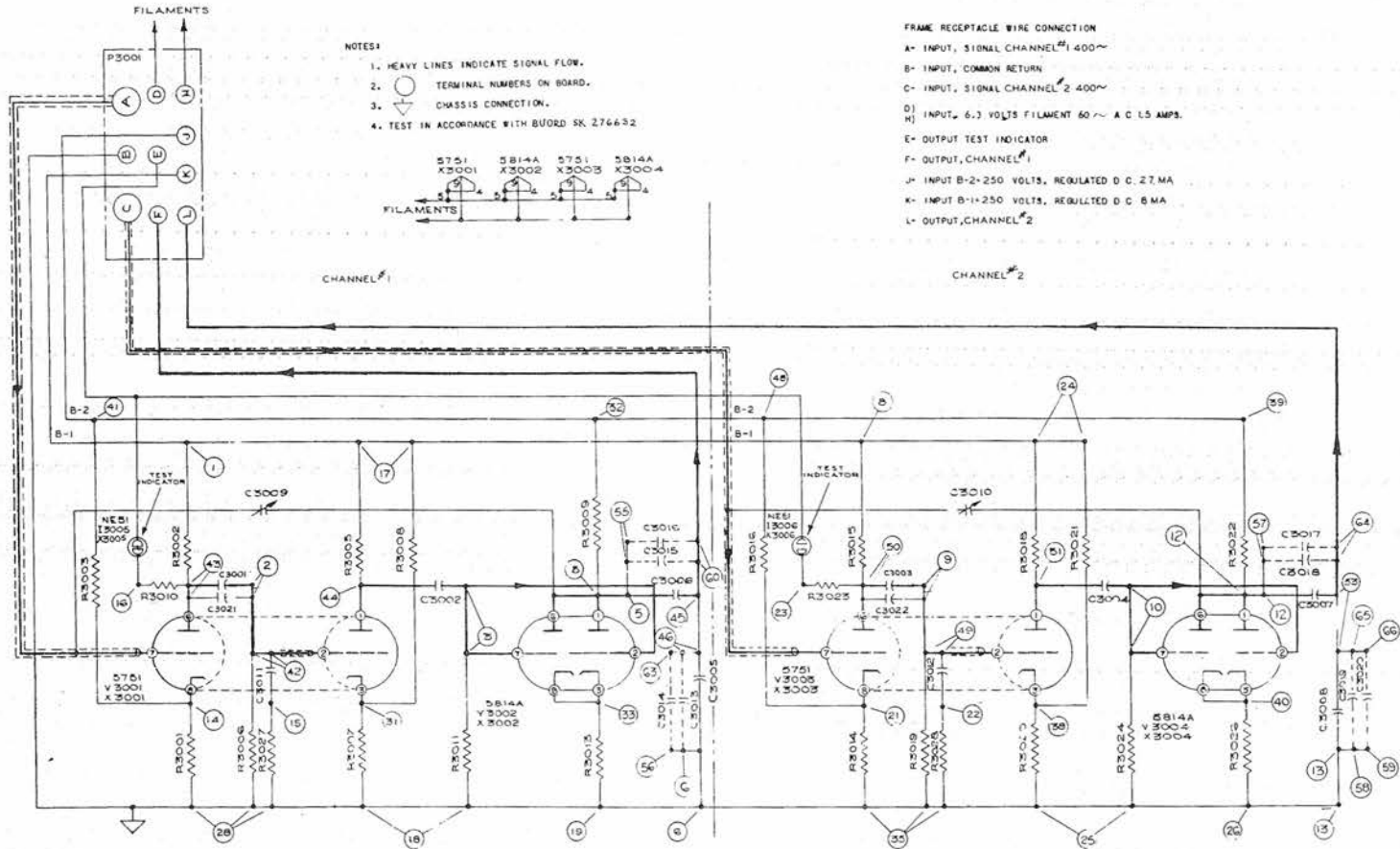

Figure 76. Dual-Channel Amplifier, Schematic Diagram (Unit 3002)

Table 48

## UNIT 3002 - RESISTANCE AND VOLTAGE TESTS

BuOrd Dwg 980156

## Resistance Tests

Terminal	Normal	Minimum	Maximum
2	2.4M	2.3M	2.5M
3	470K	423K	517K
6,13,18,19	0	0	0
25,26,28,35	0	0	0
8	53K	50.3K	55.7K
9	2.4M	2.3M	2.5M
10	470K	423K	517K
14	470	446	494
15	56K	53.2K	58.8K
21	470	446	494
22	56K	53.2K	58.8K
31	470	446	494
32	55K	52.25K	57.75K
33	560	532	588
38	470	446	494
40	560	532	588
42	1.5M	1.42M	1.58M
49	1.5M	1.42M	1.58M
56,53,59	0	0	0
8,17,24 to 1	0	0	0
32,39,48 to 41	0	0	0
43 to 1	470	446	494
44 to 1	470	446	494
50 to 1	470	446	494
51 to 1	470	446	494
5 to 41	12K	11.4K	12.6K
12 to 41	12K	11.4K	12.6K
43 to 16	75K	71.25K	78.75K
50 to 23	75K	71.25K	78.75K

## DC Voltage Tests

Terminal	Volts	Terminal	Volts
14,21,31,38	+1.2	43,44,50,51	+85
33,40	+1.5	55,57	+125

Voltage tolerance  $\pm 20$  per cent. Measurements made with two input grids grounded to chassis.

Table 49  
UNIT 3002 - PARTS LIST

SYMBOL	DESCRIPTION	VALUE	RATING	TOL	DRAWING NO	QUAN
X3006	SOCKET				1000447	2
X3005						
X3004						
X3003					12-Z-7510-114	4
X3002	SOCKET					
X3001						
I3005	LAMP NE-51				N17-L-6806-130	2
I3008						
V3004	TUBE(5814A)					1
V3003	TUBE(5751)				12-Z-13005-574	1
V3002	TUBE(5814A)					1
V3001	TUBE(5751)				12-Z-13005-574	1
P3001	CONNECTOR				12-Z-7113-6389	1
R3028	RESISTOR	56 K	1/2 WATT	± 5%	12-Z-13111-292	1
R3027	RESISTOR	56 K	1/2 WATT	± 5%	12-Z-13111-292	1
R3026	RESISTOR	560 Ω	1/2 WATT	± 5%	12-Z-13111-214	1
R3024	RESISTOR	470 K	1/2 WATT	± 10%	12-Z-13111-350	1
R3023	RESISTOR	75 K	1/2 WATT	± 5%	12-Z-13111-295	1
R3022	RESISTOR	12K	2 WATT	± 5%	12-Z-13110-964	1
R3021	RESISTOR	110 K	1 WATT	± 5%	12-Z-13111-530	1
R3020	RESISTOR	470 Ω	1/2 WATT	± 5%	12-Z-13111-212	1
R3019	RESISTOR	2.4 M	1/2 WATT	± 5%	12-Z-13111-331	1
R3018	RESISTOR	470 K	1/2 WATT	± 5%	12-Z-13111-314	1
R3016	RESISTOR	110 K	1 WATT	± 5%	12-Z-13111-530	1
R3015	RESISTOR	470K	1/2 WATT	± 5%	12-Z-13111-314	1
R3014	RESISTOR	470Ω	1/2 WATT	± 5%	12-Z-13111-212	1
R3013	RESISTOR	560 Ω	1/2 WATT	± 5%	12-Z-13111-214	1
R3011	RESISTOR	470 K	1/2 WATT	± 10%	12-Z-13111-350	1
R3010	RESISTOR	75 K	1/2 WATT	± 5%	12-Z-13111-295	1
R3009	RESISTOR	12K	WATT	± 5%	12-Z-13110-964	1
R3008	RESISTOR	110 K	1 WATT	± 5%	12-Z-13111-530	1
R3007	RESISTOR	470 Ω	1/2 WATT	± 5%	12-Z-13111-212	1
R3006	RESISTOR	2.4M	1/2 WATT	± 5%	12-Z-13111-331	1
R3005	RESISTOR	470 K	1/2 WATT	± 5%	12-Z-13111-314	1
R3003	RESISTOR	110 K	1 WATT	± 5%	12-Z-13111-530	1
R3002	RESISTOR	470 K	1/2 WATT	± 5%	12-Z-13111-314	1
R3001	RESISTOR	470Ω	1/2 WATT	± 5%	12-Z-13111-212	1
C3020				100 WVDC		
C3019				100 WVDC		
C3018				300 WVDC		
C3017				300 WVDC		
C3016				300 WVDC		
C3015				300 WVDC		
C3014				100 WVDC		
C3013				100 WVDC		
C3012	CAPACITOR	.001 MFD	300 WVDC	± 10%	12-Z-13100-9499	2
C3011						
C3010	CAPACITOR	9-16 MMF			51-128	2
C3009						
C3008	CAPACITOR	.068MFD	100 WVDC	± 10%	12-Z-13100-9269	1
C3007						
C3006	CAPACITOR	.1 MFD	300 WVDC	± 10%	12-Z-13100-9559	2
C3005	CAPACITOR	.068MFD	100 WVDC	± 10%	12-Z-13100-9269	1
C3022						
C3021						
C3004	CAPACITOR	.1 MFD	300 WVDC	± 10%	12-Z-13100-9559	6
C3003						
C3002						
C3001						

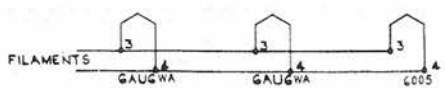
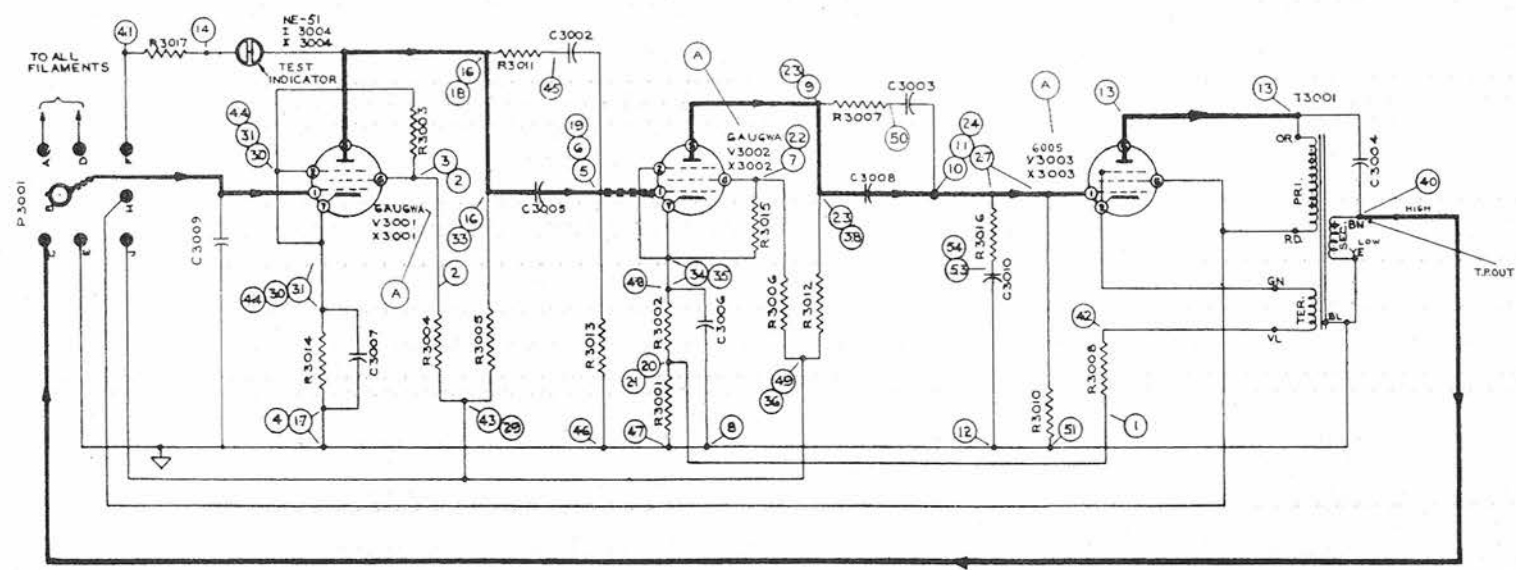

- FRAME RECEPTACLE WIRE CONNECTIONS
- 1 INPUT 6.3-VOLT FILAMENT, 60V A C, 1.05 AMPS. (D C POTENTIAL-GRD).
  - 2 INPUT SIGNAL 500 ~
  - 3 OUTPUT SIGNAL 12 VOLTS, 400 ~ INTO 500 OHM LOAD.
  - 4 INPUT, COMMON RETURN
  - 5 OUTPUT, TEST INDICATOR.
  - 6 INPUT 8-250 VOLTS REGULATED D C, .087 AMPS.
  - 7 INPUT 8-250 VOLTS REGULATED D C, .007 AMPS.

- NOTES:
- 1. ○ = TERMINAL POINTS ON TERMINAL BOARD.
  - 2. ▽ = CHASSIS CONNECTION.
  - 3. SIGNAL FLOW INDICATED BY HEAVY LINES.
  - 4. TEST IN ACCORDANCE WITH BUORD SK NO 265607

Figure 77. Computing Amplifier, Variable-Feedback, Schematic Diagram (Unit 3011)

Table 50  
UNIT 3011 - RESISTANCE AND VOLTAGE TESTS

BuOrd Dwg 1371876

Resistance Tests

Terminals	Normal	Minimum	Maximum
1	1.8	1.7	1.9
2,3	20.3K	18.3K	22.3K
4	0		
5,6	1M	950K	1.05M
7	20.3K	18.3K	22.3K
8	0		
9	211K	193K	229K
10,11	560K	504K	616K
12	0		
13,14	Infinite		
16	211K	193K	229K
17	0		
18	211K	193K	229K
19	1M	950K	1.05M
20,21	1.8	1.7	1.9
22	20.3	18.3K	22.3K
23	211K	193K	229K
24	560K	504K	616K
27	560K	504K	616K
29	61.2K	55.1K	67.3K
30,31	468	444	492
33	211K	193K	229K
34,35	332	315	349
36	61.2K	55.1K	67.3K
38	211K	193K	229K
40	16	15	17
41	Infinite		
42	622	587	653
43	61.2K	55.1K	67.3K
44	468	444	492
45	1.41M	1.33M	1.49M
46,47	0		
48	332	315	349
49	61.2K	55.1K	67.3K
50	5.31M	5.04M	5.59M
51	0		
53,54	599K	541K	657K

Table 50 (Cont'd)

## UNIT 3011 - RESISTANCE AND VOLTAGE TESTS

BuOrd Dwg 1371876

## Resistance Tests (Cont'd)

Terminals	Normal	Minimum	Maximum
13 to Pin H (P3001)	255	242	268
42 to Pin 2 (X3003)	19	18	20
41 to 14	75K	71.2K	78.8K

## DC Voltage Tests

Terminals	Voltage $\pm 20\%$	Terminal	Voltage $\pm 20\%$
1	0.05	16	160
2	44	29	250
4,5	0	31	1.1
7	40	34	0.85
9	170	40	0
10	0	41	87.5
13	243	42	16

Table 51  
UNIT 3011 - PARTS LIST

SYMBOL	DRAWING NO	PC NO	NOMENCLATURE	VALUE	RATING	TOL	NO PER
I3004	17-L-6806	130	LAMP, NEON GLOW TYPE MAZDA CAT. NO. DR EQUAL NE51				1
X3004	12-Z-7499	17	LAMPHOLDER				1
X3003	12-Z-7510	112	SOCKET, ELECTRON TUBE, 7 PIN BE.CU.SI. PLATED HOT TIN DIPPED				1
X3002 X3001	12-Z-7510	113	SOCKET, ELECTRON TUBE, 7 PIN JAN TYPE TS102P01				2
Y3003	12-Z-13005	620	TUBE, ELECTRON, 6005/GARSW MINIATURE POWER AMPL. REC.				1
V3002 Y3001	16-T-54203	53	TUBE, ELECTRON, 6AU6WA, 7 PIN MINIATURE BUTTON BASE				2
T3001	5K 13737		TRANSFORMER (595596)				1
P3001	12-Z-7113	6331	CONNECTOR, PLUG 7 LUG, 1 COAX. CONTACT, MTG. STUDS, 1.562 C/D				1
R3017	12-Z-13111	295	RESISTOR, FIXED COMPOSITION .175 DIA. X .406 LONG	75 K	1/2 WATT	± 5%	1
R3016	12-Z-13111	248	RESISTOR, FIXED COMPOSITION .175 DIA. X .406 LONG	15 K	1/2 WATT	± 5%	1
R3015	12-Z-13111	287	RESISTOR, FIXED COMPOSITION .175 DIA. X .406 LONG	22 K	1/2 WATT	± 10%	1
R3014	12-Z-13110	837	RESISTOR, FIXED WIRE WOUND 15/64 DIA. X 21/32 LONG	470 Ω	1/2 WATT	± 5%	1
R3013	12-Z-13111	322	RESISTOR, FIXED COMPOSITION .175 DIA. X .406 LONG	1.0 M	1/2 WATT	± 5%	1
R3012	12-Z-13111	352	RESISTOR, FIXED COMPOSITION .175 DIA. X .406 LONG	0.15 M	1/2 WATT	± 10%	1
R3011	12-Z-13111	324	RESISTOR, FIXED COMPOSITION .175 DIA. X .406 LONG	1.2 M	1/2 WATT	± 5%	1
R3010	12-Z-13111	359	RESISTOR, FIXED COMPOSITION .175 DIA. X .406 LONG	0.56 M	1/2 WATT	± 10%	1
R3008	12-Z-13110	904	RESISTOR, FIXED WIRE WOUND 15/64 DIA. X 19/32 LONG	620 Ω	1 WATT	± 5%	1
R3007	12-Z-13111	339	RESISTOR, FIXED COMPOSITION .175 DIA. X .406 LONG	5.1 M	1/2 WATT	± 5%	1
R3006	12-Z-13111	585	RESISTOR, FIXED COMPOSITION .28 DIA. X .750 LONG	0.1 M	1/2 WATT	± 10%	1
R3005	12-Z-13111	352	RESISTOR, FIXED COMPOSITION .175 DIA. X .406 LONG	0.15 M	1/2 WATT	± 10%	1
R3004	12-Z-13111	585	RESISTOR, FIXED COMPOSITION .28 DIA. X .750 LONG	0.1 M	1 WATT	± 10%	1
R3003	12-Z-13111	287	RESISTOR, FIXED COMPOSITION .175 DIA. X .406 LONG	22 K	1/2 WATT	± 10%	1
R3002	16-R-68373	1526	RESISTOR, FIXED, WIRE WOUND 15/64 DIA. X 21/32 LONG	330 Ω	1/2 WATT	± 5%	1
R3001	12-Z-13110	799	RESISTOR, FIXED, WIRE WOUND 15/64 DIA. X 21/32 LONG	1.8 Ω	1/2 WATT	± 5%	1
C3010	16-C-32720	7533	CAPACITOR, FIXED MICA, DIELEC. 53/64 X 53/64 X 11/32	5100 MMFD	500 WVDC	± 5%	1
C3009	16-C-30188	5001	CAPACITOR, FIXED MICA, DIELEC. 31/64 X 15/32 X 7/32	510 MMFD	500 WVDC	± 5%	1
C3008	12-Z-13100	9547	CAPACITOR, FIXED PAPER DIELEC. .312 DIA. 7/8 LONG	.01 MFD	300 WVDC	± 10%	1
C3007	16-C-32646	6813	CAPACITOR, FIXED MICA, DIELEC. 53/64 X 53/64 X 11/32	4700 MMFD	500 WVDC	± 10%	1
C3006	16-C-31908	1569	CAPACITOR, FIXED MICA, DIELEC. 53/64 X 53/64 X 9/32	2200 MMFD	500 WVDC	± 10%	1
C3005	12-Z-13100	9547	CAPACITOR, FIXED PAPER, DIELEC. .312 DIA. 7/8 LONG	.01 MFD	300 WVDC	± 10%	1
C3004	12-Z-13100	9587	CAPACITOR, FIXED PAPER, DIELEC. .400 DIA. 7/8 LONG	.051 MFD	300 WVDC	± 5%	1
C3003 C3002	12-Z-13100	9559	CAPACITOR, FIXED PAPER, DIELEC. .400 DIA. 1 3/8 LONG	0.1 MFD	300 WVDC	± 10%	2

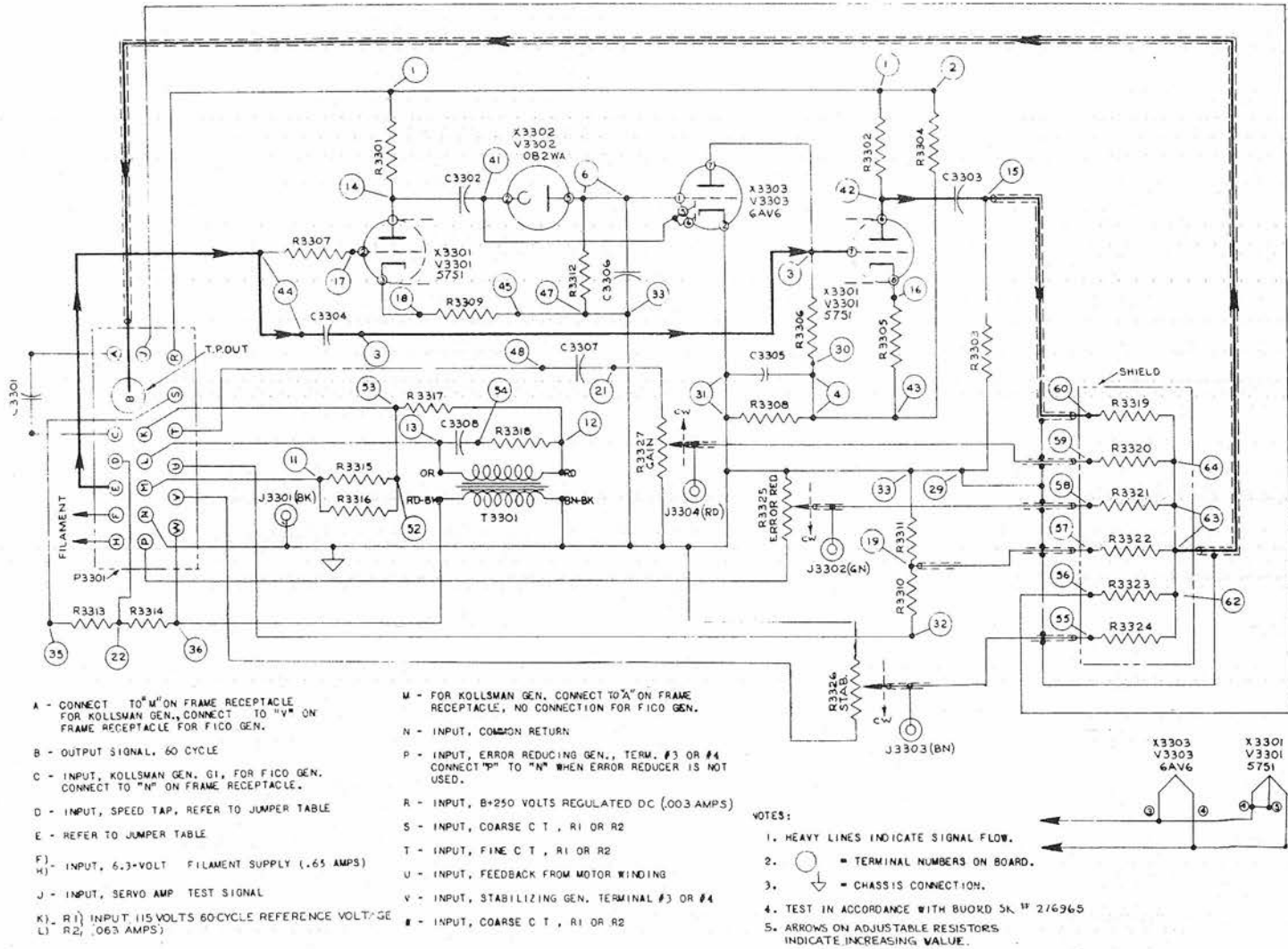

- A - CONNECT TO "M" ON FRAME RECEPTACLE FOR KOLLSMAN GEN., CONNECT TO "V" ON FRAME RECEPTACLE FOR FICO GEN.
- B - OUTPUT SIGNAL, 60 CYCLE
- C - INPUT, KOLLSMAN GEN. G1, FOR FICO GEN. CONNECT TO "M" ON FRAME RECEPTACLE.
- D - INPUT, SPEED TAP, REFER TO JUMPER TABLE
- E - REFER TO JUMPER TABLE
- F) - INPUT, 6.3-VOLT FILAMENT SUPPLY (.65 AMPS)
- H) - INPUT, SERVO AMP TEST SIGNAL
- K) - R1) INPUT 115 VOLTS 60CYCLE REFERENCE VOLTAGE  
L) R2) .063 AMPS
- M - FOR KOLLSMAN GEN. CONNECT TO "A" ON FRAME RECEPTACLE, NO CONNECTION FOR FICO GEN.
- N - INPUT, COMMON RETURN
- P - INPUT, ERROR REDUCING GEN., TERM. #3 OR #4 CONNECT "P" TO "N" WHEN ERROR REDUCER IS NOT USED.
- R - INPUT, B+250 VOLTS REGULATED DC (.003 AMPS)
- S - INPUT, COARSE C T, R1 OR R2
- T - INPUT, FINE C T, R1 OR R2
- U - INPUT, FEEDBACK FROM MOTOR WINDING
- V - INPUT, STABILIZING GEN. TERMINAL #3 OR #4
- W - INPUT, COARSE C T, R1 OR R2

Figure 78. Servo Control, Double-Speed, Velocity-Lag, Schematic Diagram (Unit 3304)

**Table 52**  
**UNIT 3304 - RESISTANCE AND VOLTAGE TESTS**  
 BuOrd Dwg 980419  
 Resistance Tests

Terminals	RESISTANCE*		
	Normal	Minimum	Maximum
1	124K	117K	131K
2	124K	117K	131K
3	705K	670K	740K
4	24K	22.8K	25.2K
6	1M	900K	1.1M
11	Infinite	---	---
12	Infinite	---	---
13	Infinite	---	---
14	344K	327K	361K
15	730K	660K	790K
16	28.3K	26.9K	29.7K
17	INFINITE	---	---
18	9.1K	8.6K	9.6K
19	1K	0.95K	1.05K
21	100K	90K	110K
22	47K	44.5K	49.5K
29	0	0	0
30	24K	22.8K	25.2K
31	0	0	0
32	52K	49K	55K
33	0	0	0
35	94K	89K	100K
36	60	54	66
41	Infinite	---	---
42	514K	463K	565K
43	24K	22.8K	25.2K
44	Infinite	---	---
45	0	0	0
47	0.	0	0
48	Infinite	---	---
55	100K	90K	110K
56	2.64M	2.5M	2.8M
57	1K	0.95K	1.05K
58	100K	90K	110K
59	100K	90K	110K
60	730K	700K	760K
62	770K	740K	1M
63	770K	740K	1M
64	770K	740K	1M
11 to 52	0.75K	0.71K	0.79K
12 to 13	190	170	210
12 to 53	39K	58K	66K
12 to 54	1.8K	1.7K	1.9K

\*All controls completely turned clockwise.

Table 52 (Cont'd)

## UNIT 3304 - RESISTANCE AND VOLTAGE TESTS

BuOrd Dwg 980419

## DC Voltage Test

Terminals	Volts	Terminals	Volts
17	0	42	+240
18	+2.8	16	+47
14	+165	2	+250
3	+19	1	+250
4	+48		

Voltage tolerance  $\pm 10$  per cent. Measurements made with input grid grounded to chassis.

Table 53  
UNIT 3304 - PARTS LIST

SYMBOL	DRAWING NO	PIECE NO	NOMENCLATURE	VALUE	RATING	TOL	NO REQ
T3301	LD NO 137397 (DWG NO) 595753		TRANSFORMER				1
X3303		113	SOCKET, ELECTRON TUBE, 7 PIN JAN TYPE TS102PJ				2
X3302	12-Z-7510						
X3301	12-Z-7510	114	SOCKET, ELECTRON TUBE, 9 PIN JAN TYPE TS103PCJ				1
V3303	16-T-56203	60	ELECTRON TUBE, 6AV6 RECEIVING MINIATURE DBL D. HI MU TRI				1
V3302			ELECTRON TUBE, 6B2WA MINIATURE				1
V3301	12-Z-13005	574	ELECTRON TUBE 5751 DBL. TRI. VOLTAGE AMPLIFIER 9 PIN				1
P3301	12-Z-7113	6340	CONNECTOR, PLUG, 18 LUG 1 COAX CONTACT MTG STUDS 2.688 *C/C				1
J3304	12-Z-7113	3001	CONNECTOR, RECPT. BR. NI PL RD NYLON INSUL. WITH MTG NUT				1
J3303	12-Z-7113	3003	CONNECTOR, RECPT. BR. NI PL BN NYLON INSUL. WITH MTG NUT				1
J3302	12-Z-7113	3004	CONNECTOR, RECPT. BR. NI PL GN NYLON INSUL. WITH MTG NUT				1
J3301	12-Z-7113	3002	CONNECTOR, RECPT. BR. NI PL BK NYLON INSUL. WITH MTG NUT				1
R3327							
R3326	12-Z-13110	9273	RESISTOR (ADJ.)	100 K OHMS	2 WATT	+10%	3
R3325							
R3324							
R3323	625225	3	RESISTOR, 5/8 LG X 1/4 DIA.	2.2 MEG OHM	1/2 WATT	+1%	6
R3322							
R3321							
R3320							
R3319							
R3318	12-Z-13111	226	RESISTOR, FIXED COMPOSITION, .406 LG X .175 DIA.	1.8 K OHMS	1/2 WATT	+5%	1
R3317	12-Z-13111	258	RESISTOR, FIXED COMPOSITION, .406 LG X .175 DIA.	39 K OHMS	1/2 WATT	+5%	1
R3316	12-Z-13111	741	RESISTOR, FIXED COMPOSITION, .750 LG X .370 DIA.	1.5 K OHMS	2 WATT	+10%	2
R3315							
R3314	12-Z-13111	260	RESISTOR, FIXED COMPOSITION, .406 LG X .275 DIA.	47 K OHMS	1/2 WATT	+5%	2
R3313							
R3312	12-Z-13111	362	RESISTOR, FIXED COMPOSITION, .406 LG X .175 DIA.	1.0 MEG OHM	1/2 WATT	+10%	1
R3311	12-Z-13111	220	RESISTOR, FIXED COMPOSITION, .406 LG X .175 DIA.	1.0 K OHMS	1/2 WATT	+5%	1
R3310	12-Z-13111	261	RESISTOR, FIXED COMPOSITION, .406 LG X .175 DIA.	51 K OHMS	1/2 WATT	+5%	1
R3309	12-Z-13111	243	RESISTOR, FIXED COMPOSITION, .406 LG X .175 DIA.	9.1 K OHMS	1/2 WATT	+5%	1
R3308	12-Z-13111	483	RESISTOR, FIXED COMPOSITION, .750 LG X .280 DIA.	24 K OHMS	1 WATT	+5%	1
R3307	12-Z-13111	358	RESISTOR, FIXED COMPOSITION, .406 LG X .175 DIA.	470 K OHMS	1/2 WATT	+10%	1
R3306	12-Z-13111	318	RESISTOR, FIXED COMPOSITION, .406 LG X .175 DIA.	680 K OHMS	1/2 WATT	+5%	1
R3305	12-Z-13111	235	RESISTOR, FIXED COMPOSITION, .406 LG X .175 DIA.	4.3 K OHMS	1/2 WATT	+5%	1
R3304	12-Z-13111	529	RESISTOR, FIXED COMPOSITION, .750 LG X .280 DIA.	100 K OHMS	1 WATT	+5%	1
R3303	12-Z-13111	362	RESISTOR, FIXED COMPOSITION, .406 LG X .175 DIA.	1.0 MEG OHM	1/2 WATT	+10%	1
R3302	12-Z-13111	357	RESISTOR, FIXED COMPOSITION, .406 LG X .175 DIA.	390 K OHMS	1/2 WATT	+10%	1
R3301	12-Z-13111	306	RESISTOR, FIXED COMPOSITION, .406 LG X .175 DIA.	220 K OHMS	1/2 WATT	+5%	1
C3308	12-Z-13100	9333	CAPACITOR, FIXED PAPER, 1 5/8 LG X .562 DIA.	.68 MFD	100 WVDC	+10%	1
C3307	12-Z-13100	9259	CAPACITOR, FIXED PAPER, 3/4 LG X .235 DIA.	.01 MFD	100 WVDC	+10%	1
C3306	12-Z-13100	9394	CAPACITOR, FIXED PAPER, 1 1/8 LG X .400 DIA.	0.1 MFD	200 WVDC	+20%	1
C3305	12-Z-13100	9449	CAPACITOR, FIXED PAPER, 7/8 LG X .400 DIA.	.051 MFD	200 WVDC	+5%	1
C3304	16-C-31903	1089	CAPACITOR, FIXED MICA, 53/64 X 53/64 X 11/32	2200 MMFD	500 WVDC	+5%	1
C3303	12-Z-13100	9551	CAPACITOR, FIXED PAPER, 7/8 LG X .312 DIA.	.022 MFD	300 WVDC	+10%	1
C3302	16-C-32720	7533	CAPACITOR, FIXED MICA, 53/64 X 53/64 X 11/32	5100 MMFD	500 WVDC	+5%	1
C3301	986504	5	CAPACITOR	1.0 MFD	400 WVDC	+10%	1

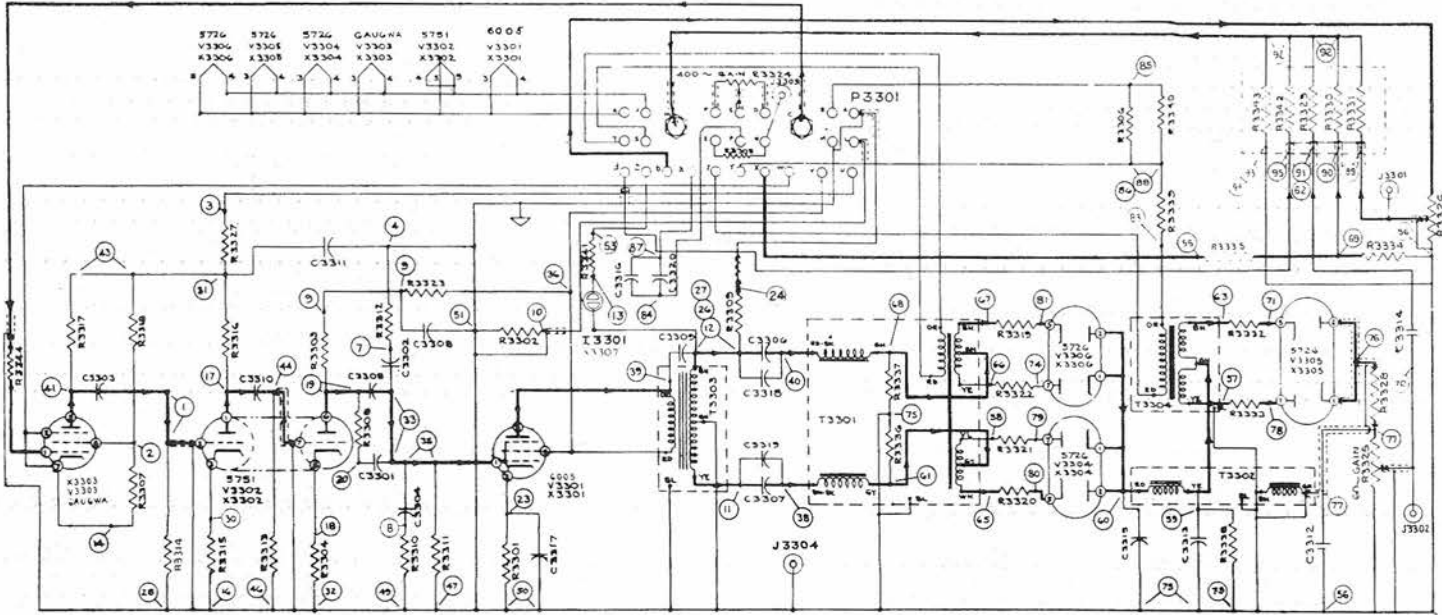

**FEEDBACK TABLE**

NORMAL OPERATION	"X" COMPENSATION	DOUBLE "X" COMPENSATION

**GEN CONNECTION TABLE**

FICO GENERATOR	HOLLMAN GENERATOR

- FRAME RECEPTACLE WIRE CONNECTIONS**
- 1. CONNECTIONS TO FEEDBACK POT. SEE FEEDBACK TABLE AT LEFT.
  - 2. CONNECTIONS TO RATE GENERATOR SEE GEN. CONNECTION TABLE AT LEFT.
  - C INPUT SIGNAL (400 CYCLE)
  - H OUTPUT SIGNAL 60-70 SERVO AMPLIFIER
  - 2) INPUT, FILAMENT SUPPLY (6.3V., 2.0 AMP. D.C. POT. GND)
  - M INPUT, COMMON RETURN
  - 3) INPUT, 12 VOLTS 400 CYCLE A.C. REFERENCE 0.07
  - U INPUT B1 +250 VOLTS REGULATED D.C. .004 AMPS
  - V INPUT B2 +250 VOLTS REGULATED D.C. .033 AMPS
  - X INPUT, (FEEDBACK FROM MOTOR WINDING)
  - Y R1 INPUT, REFERENCE 115 VOLTS 60-CYCLE A.C. .063 AMPS.
  - Z R2 OUTPUT TEST INDICATOR FOR SERVO CONTROL
  - A INPUT SERVO AMPLIFIER TEST SIGNAL

- NOTES:**
- 1. ○ - TERMINAL POINTS ON TERMINAL BOARD.
  - 2. ⊕ - CHASSIS CONNECTION.
  - 3. TEST IN ACCORDANCE WITH BUORD SK 276-27
  - 4. SIGNAL FLOW INDICATED BY HEAVY LINES.
  - 5. \* - VALUE TO BE DETERMINED AT TEST.

STRAPS SHOWN ABOVE AND RESISTOR (3300; 1/2 WATT WIRE-BOUND) ARE TO BE MOUNTED ON FEMALE CONNECTOR (J3306). POTENTIOMETERS, 25k AND 330Ω, ARE EXTERNALLY MOUNTED.

Figure 79. Servo Control, Velocity-Lag, 400-cycles, Schematic Diagram (Unit 3301)

Table 54  
UNIT 3301 - RESISTANCE AND VOLTAGE TESTS

BuOrd Dwg 980602

## Resistance Tests

Terminal	Normal	Minimum	Maximum
M	0	0	0
1 to 4	100K	95K	105K
2 to 43	100K	90K	110K
3 to 43	10K	8K	12K
7	100K	90K	110K
8	5.6K	5.0K	6.2K
9	Infinite	---	---
9 to 19	100K	90K	110K
9 to 36	10K	8K	12K
10	200	180	220
11	85	76.5	93.5
12	85	76.5	93.5
14	Infinite	---	---
14 to 43	122	109.8K	132.2K
16	0	0	0
17 to 43	220K	198K	222K
18	510	485	535
19 to 20	5.6M	5.1M	6.1M
23	620	590	650
24	39K	38.5K	39.5K
26	85	76.5	93.5
27	85	76.5	93.5
28	0	0	0
30	510	485	535
33	820K	740K	900K
35	820K	740K	900K
36	Infinite	---	---
38	1.8K	1.7K	1.9K
40	1.8K	1.7K	1.9K
44	100K	95K	105K
46	0	0	0
47	0	0	0
49	0	0	0
50	0	0	0
51	0	0	0
55	52K	54.6K	49.4K
56	0	0	0
57	15.5K	14.7K	16.3K
58	1.6K	1.5K	1.7K
59	15K	14.3K	15.8K
60	15.8K	15K	16.6K
61	1.5K	1.43K	1.58K
63	15.5K	14.7K	16.3K
65	1.6K	1.5K	1.7K
66	1.6K	1.5K	1.7K

Table 54 (Cont'd)

## UNIT 3301 - RESISTANCE AND VOLTAGE TESTS

BuOrd Dwg 980602

## Resistance Tests

Terminal	Normal	Minimum	Maximum
67	1.6K	1.5K	1.7K
68	1.5K	1.43K	1.58K
69	1K	0.95K	1.05K
71	33.5K	31.8K	35.2K
73	0	0	0
74	5.5K	5.2K	5.8K
75	0	0	0
76	19.1K	17.2K	21K
77	1.1K	900	1.3K
78	33.5K	31.8K	35.2K
79	5.5K	5.2K	5.8K
80	5.5K	5.2K	5.8K
81	5.5K	5.2K	5.8K
85 to 83	11.8K	11K	12.5K
85	Infinite	---	---
85 to 88	750	675	825
85 to 86	750	675	825
95 to 92	2.2M	---	---
91 to 92	2.2M	---	---
92	505K	---	---
83 to Z	200	160	240
F to D	25K	20K	30K
R to N	27K	25.6K	28.4K
C to I	100K	80K	120K

Stabilizer and 60-cycle gain control completely turned counterclockwise.

## DC Voltage Tests

Terminal	Volts	Terminal	Volts
1	0	28	0
2	+36	30	+0.3
8	0	31	+210
9	+240	32	0
10	0	33	0
14	+0.8	35	0
16	0	41	+158
17	+91	43	+210
18	+0.6	44	0
19	+123	46	0
20	+55	47	0
23	+16	49	0
24	0	51	0
26	0		0

Voltage tolerance  $\pm 20$  per cent. Measurements made with input grid grounded to chassis.

Table 55  
UNIT 3301 - PARTS LIST

SYMBOL	DESCRIPTION	VALUE	RATING	TOL	DWG NO	PG NO	REQ
C3315	CAPACITOR	.047 MFD	100 WVDC	±10%	12-Z-13100	9267	1
C3314	CAPACITOR	.01 MFD	300 WVDC	±10%	625196	133	1
C3313	CAPACITOR	.047 MFD	100 WVDC	±10%	12-Z-13100	9267	1
C3312	CAPACITOR	0.1 MFD	300 WVDC	±20%	12-Z-13100	9541	1
C3311	CAPACITOR	.022 MFD	300 WVDC	±20%	12-Z-13100	9537	1
C3310	CAPACITOR	.47 MFD	300 WVDC	±20%	12-Z-13100	9545	1
C3309	CAPACITOR	.047 MFD	300 WVDC	±20%	12-Z-13100	9539	1
C3308	CAPACITOR	.022 MFD	300 WVDC	±20%	12-Z-13100	9537	1
C3307	CAPACITOR		100 WVDC		12-Z-13100	*	2
C3306	CAPACITOR						
C3305	CAPACITOR	.022 MFD	300 WVDC	±20%	12-Z-13100	9537	1
C3304	CAPACITOR	.0068 MFD	300 WVDC	±10%	625196	129	1
C3303	CAPACITOR	0.1 MFD	300 WVDC	±20%	12-Z-13100	9541	2
C3302	CAPACITOR	.047 MFD	300 WVDC	±20%	12-Z-13100	9539	1
X3307	SOCKET				1000447		1
X3302	SOCKET				12-Z-7510	114	1
X3306							
X3305							
X3304	SOCKET				12-Z-7510	113	5
X3303							
X3301							
V3306							
V3305	TUBE (726)						3
V3304							
V3303	TUBE (6AUGWA)						1
V3302	TUBE (5751)				12-Z-13005	574	1
V3301	TUBE (6005)						1
J3304	TIP JACK				12-Z-7113	3002	1
J3303	TIP JACK				12-Z-7113	3005	1
J3302	TIP JACK				12-Z-7113	3001	1
J3301	TIP JACK				12-Z-7113	3003	1
T3301	LAMP (NE 51)				N17-L-6806	130	1
T3304	TRANSFORMER(595753)				SK 137367		1
T3303	TRANSFORMER(595671)				SK 137345		1
T3302	TRANSFORMER(595669)				SK 137354		1
T3301	TRANSFORMER(595982)				SK 272904		1
P3301	CONNECTOR				12-Z-7113	6393	1
R3344	RESISTOR	0.1 MEG	1/2 WATT	±10%	12-Z-13111	350	1
R3343	RESISTOR	1.1 MEG	1/2 WATT	±1%	625225	57	1
R3342	RESISTOR	2.2 MEG	1/2 WATT	±1%	625225	3	1
R3341	RESISTOR	10 K	1/2 WATT	±5%	12-Z-13111	244	1
R3340	RESISTOR	1.5 K	2 WATT	±10%	12-Z-13111	741	1
R3339	RESISTOR	11 K	2 WATT	±5%	12-Z-13111	707	1
R3338	RESISTOR	15 K	1 WATT	±5%	12-Z-13111	478	1
R3337	RESISTOR	1.5 K	1 WATT	±5%	12-Z-13111	454	2
R3336	RESISTOR						
R3335	RESISTOR	51 K	1/2 WATT	±5%	12-Z-13111	261	1
R3334	RESISTOR	1 K	1/2 WATT	±5%	12-Z-13111	220	1
R3333	RESISTOR	18 K	1/2 WATT	±1%	625225		1
R3332	RESISTOR		1/2 WATT		12-Z-13111	*	1
R3331	RESISTOR	2.2 MEG	1/2 WATT	±1%	625225	3	3
R3330	RESISTOR						
R3328	RESISTOR	48 K	1/2 WATT	±10%	12-Z-13111	286	1
R3327	RESISTOR	10 K	1 WATT	±10%	12-Z-13111	517	1
R3326	ADJ. RESISTOR	0.1 MEG	2 WATT	±20%	626052	68	2
R3325	RESISTOR						
R3324	ADJ. RESISTOR	25 K	2 WATT	±20%	626052	176	1
R3323	RESISTOR	10 K	1 WATT	±10%	12-Z-13111	517	1
R3322	RESISTOR	3.9 K	1/2 WATT	±1%	625225	8	4
R3321	RESISTOR						
R3320	RESISTOR						
R3319	RESISTOR						
R3318	RESISTOR	100 K	1 WATT	±10%	12-Z-13111	585	1
R3317	RESISTOR	0.15 MEG	1/2 WATT	±5%	12-Z-13111	302	1
R3316	RESISTOR	0.22 MEG	1/2 WATT	±10%	12-Z-13111	354	1
R3315	RESISTOR	510 Ω	1/2 WATT	±5%	12-Z-13111	213	1
R3314	RESISTOR	0.1 MEG	1/2 WATT	±5%	12-Z-13111	298	2
R3313	RESISTOR						
R3312	RESISTOR	0.1 MEG	1/2 WATT	±10%	12-Z-13111	350	1
R3311	RESISTOR	0.82 MEG	1/2 WATT	±10%	12-Z-13111	361	1
R3310	RESISTOR	5.6 K	1/2 WATT	±10%	12-Z-13111	280	1
R3309	RESISTOR	39 K	1/2 WATT	±1%	625225	19	1
R3308	RESISTOR	5.6 MEG	1/2 WATT	±10%	12-Z-13111	371	1
R3307	RESISTOR	22 K	1/2 WATT	±10%	12-Z-13111	287	1
R3306	RESISTOR	1.5 K	2 WATT	±10%	12-Z-13111	741	1
R3305	RESISTOR	27 K	1/2 WATT	±5%	12-Z-13111	254	1
R3304	RESISTOR	510 Ω	1/2 WATT	±5%	12-Z-13111	213	1
R3303	RESISTOR	0.1 MEG	1/2 WATT	±10%	12-Z-13111	350	1
R3302	RESISTOR	200 Ω	1/2 WATT	±1%	625225	43	1
R3301	RESISTOR	620 Ω	1 WATT	±5%	12-Z-13111	445	1
C3320	CAPACITOR	.47 MFD	300 WVDC	±10%	12-Z-13100	9567	1
C3319	CAPACITOR		100 WVDC		12-Z-13100	*	2
C3318	CAPACITOR						
C3317	CAPACITOR	.0051 MFD	500 WVDC	±2%	16-C-32715	6053	1
C3316	CAPACITOR	.47 MFD	300 WVDC	±10%	12-Z-13100	9567	1



Table 56

## UNIT 3302 - RESISTANCE AND VOLTAGE TESTS

BuOrd Dwg 1371797

## Resistance Tests

Rotate all controls completely counterclockwise.

Terminals	Normal	Minimum	Maximum
1	690K	621K	759K
2	75	71	79
3	185K	167K	203K
4	207K	186K	228K
5,6	0	---	---
7	150K	135K	165K
8	No connection	---	---
9	0	---	---
10,11,12	No connection	---	---
13	Infinite	---	---
14	0	---	---
15	185K	167K	203K
16	470K	446K	494K
17	1.2K	1.1K	1.3K
18	690K	621K	759K
19	53.2K	50.2K	56.2K
20	510	485	535
21	3.9K	3.7K	4.1K
22	100K	95K	105K
23,24,25, 26,27	No connection	---	---
28	1.07M	.97M	1.17M
29,30	85.6K	77.6K	94.6K
31	470K	446K	494K
32	52.3K	47.3K	57.3K
33	1.0K	0.9K	1.1K
34	No connection	---	---
35	820K	740K	900K
36	No connection	---	---
37	1.2K	1.1K	1.3K
38,39	No connection	---	---
40	Infinite	---	---
41	71.5K	64.5K	78.5K
42	95.6K	85.6K	105.6K
43	401K	361K	441K
44	Infinite	---	---
45	52K	49K	55K
46	Infinite	---	---
47	180K	162K	198K
48,49,50,51	No connection	---	---

Table 56 (Cont'd)

## UNIT 3302 - RESISTANCE AND VOLTAGE TESTS

BuOrd Dwg 1371797

## Resistance Tests

Rotate all controls completely counterclockwise.

Terminals	Normal	Minimum	Maximum
52	Infinite	---	---
53	No connection	---	---
54, 55	No connection	---	---
56	1.7K	1.6K	1.8K
57	No connection	---	---
58	20K	18K	22K
59	492K	467K	517K
60	1K	0.9K	1.1K
61, 62	No connection	---	---
63	15K	14K	16K
64, 65	5.4K	4.9K	5.9K
66	2.75M	2.70M	2.80M
67, 68	No connection	---	---
69	1.8K	1.6K	2.0K
70	1.7K	1.6K	1.8K
71	Infinite	---	---
72	80	72	88
73, 74, 75	No connection	---	---
76	33K	31K	35K
77	5.4K	4.9K	5.9K
78	5.4K	4.9K	5.9K
79, 80	15K	14K	16K
81, 82	No connection	---	---
83	80	72	88
84	Infinite	---	---
85	5.1K	4.8K	5.4K
86	1.8K	1.6K	2.0K
87	No connection	---	---
88, 89	15K	13.5K	16.5K
90	33K	31K	35K
91, 92	1.7K	1.6K	1.8K
93, 94, 95, 96	No connection	---	---
97	0	---	---
98	53.1K	49.2K	57K
99	No connection	---	---
100	20K	19.8K	20.2K
101	0	---	---

Table 58 (Cont'd)  
 UNIT 3302 - RESISTANCE AND VOLTAGE TESTS

BuOrd Dwg 1371797

## Resistance Tests

Terminals	Normal	Minimum	Maximum
102	No connection	---	---
103	15.4K	14.7K	16.2K
104,105	1.7K	1.6K	1.8K
106,107	0	---	---
108,109	No connection	---	---
110	750	712	788
111	492K	443K	541K
112	22K	21K	23K
113	492K	467K	517K
114,115	150K	142K	158K
116	22K	21K	23K
117	53.1K	49.2K	57K
118	24K	22K	26K
119	22K	21K	23K
120	22K	21K	23K
121	172K	163K	181K
122	242K	218K	266K
123	41K	37K	45K
124	No connection	---	---
125	44K	42K	46K
126	0	---	---
127	172K	163K	181K
128	150K	142K	158K
129	0	---	---
130	173K	156K	190
131	22K	21K	23K
132	44K	42K	46K
133	24K	23K	25K
134,135	150K	142K	158K
136,137,138, 139,140, 141,142	Infinite	---	---
143	0	---	---
144,145	2.75M	2.70M	2.80M
146	1.0K	0.90K	1.1K
147,148	0	---	---
149	0.55M	0.54M	0.56M
N to R (Plug 3301)	27K	25.5K	28.5K
D to F (Plug 3301)	25K	22.5K	27.5K

Table 56 (Cont'd)

## UNIT 3302 - RESISTANCE AND VOLTAGE TESTS

BuOrd Dwg 1371797

DC Voltage Tests

Terminals	Voltage $\pm 10\%$	Terminal	Voltage $\pm 10\%$
1,2	0	60	0
3	165	61,62	No connection
4	0.85	63,64,65,66	0
5,6,7	0	67,68	No connection
8	No connection	69,70,71,72	0
9	0	73,74,75	No connection
10,11,12	No connection	76,77,78	0
13,14	0	79,80	0
15	31.5	81,82	No connection
16	0	83,84,85,86	0
17	1.7	87	No connection
18	0	88,89,90	0
19	250	91,92	0
20	1.5	93,94,95,96	No connection
21,22	0	97	0
23,24,25, 26,27	No connection	98	242
28	70	99	No connection
29,30	215	100,101	0
31	0	102	No connection
32	225	103,104,105	0
33	0	106,107	0
34	No connection	108,109	No connection
35	122	110	2.6
36	No connection	111	5.8
37	20	112	73
38,39	No connection	113	72
40	0	114,115,116	0
41	103	117	250
42	250	118	80
43	80	119,120	73
44,45,46	0	121,122	0
47	138	123	127
48,49,50,51	No connection	124	No connection
52	0	125	73
53,54,55	No connection	126,127,128	0
56	0	129,130	0
57	No connection	131,132	73
58	0	133	82
59	72	134-149	0

Table 57  
UNIT 3302 - PARTS LIST

SYMBOL	DRAWING NO.	PC NO.	NOMENCLATURE	VALUE	RATING	TOL.	NO. REQ.
X331	12-2-1489	17	LAMP HOLDER				1
X339	12-2-7510	114	SOCKET				1
X339							1
X339							1
X337							1
X336	12-2-7510	113	SOCKET				7
X335							1
X334							1
X333							1
X332	12-2-7510	114	SOCKET				1
X331	12-2-7510	113	SOCKET				1
V3310	12-2-13005	652	TUBE 5814A				1
V3309	16-T-56203	53	TUBE 6A58A				1
V3308							1
V3307							1
V3306	16-T-75726		TUBE 5726				5
V3305							1
V3304							1
V3303	12-2-13005	620	TUBE 6005				1
V3302	12-2-13005	574	TUBE 5751				1
V3301	16-T-56203	53	TUBE 6A58A				1
T3305	SK 137254		TRANSFORMER 592669				1
T3304	SK 137267		TRANSFORMER 592753				1
T3302	SK 272904		TRANSFORMER 592982				1
T3301	SK 137245		TRANSFORMER 592871				1
P3301	12-2-7112	6393	CONNECTOR				1
C3304	12-2-7112	3902	CONNECTOR				1
C3303	*	3903	CONNECTOR				1
C3302	*	3901	CONNECTOR				1
C3301	*	3905	CONNECTOR				1
L3301	17-1-6896	310	LAMP				1
R3371	12-2-13110	272	RESISTOR ADJUSTABLE	.1 MEG	2 WATT	+10%	1
R3370	12-2-13111	260	RESISTOR	4.7 K	1/2 WATT	+5%	1
R3369	12-2-13111	282	RESISTOR	56K	1/2 WATT	+5%	1
R3368	12-2-13111	277	RESISTOR	750 OHMS	1/2 WATT	+5%	1
R3367	12-2-13111	291	RESISTOR	.17 MEG	1/2 WATT	+10%	1
R3366	12-2-13111	252	RESISTOR	22K	1/2 WATT	+5%	1
R3365	12-2-13111	254	RESISTOR	.22 MEG	1/2 WATT	+10%	1
R3364	12-2-13111	251	RESISTOR	4.70 MEG	1/2 WATT	+10%	1
R3363	12-2-13111	279	RESISTOR	2.2K	1/2 WATT	+10%	1
R3362	12-2-13111	252	RESISTOR	22K	1/2 WATT	+5%	1
R3361	12-2-13111	302	RESISTOR	.15 MEG	1/2 WATT	+5%	1
R3360	12-2-13111	228	RESISTOR	1.2K	1/2 WATT	+5%	1
R3359	12-2-13111	252	RESISTOR	22K	1/2 WATT	+5%	1
R3358	12-2-13111	314	RESISTOR	0.15 MEG	1/2 WATT	+5%	1
R3357							1
R3356	12-2-13110	7302	RESISTOR	27K	1/2 WATT	+5%	4
R3355							1
R3354							1
R3353	12-2-13111	*	RESISTOR	0-510 OHMS	1/2 WATT	+5%	1
R3352	12-2-13111	752	RESISTOR	12K	2 WATT	+10%	1
R3350	12-2-13110	7420	RESISTOR	7420	1/2 WATT	+1%	4
R3349							1
R3347	12-2-13110	7417	RESISTOR	1.1 MEG	1/2 WATT	+1%	1
R3346	12-2-13111	741	RESISTOR	1.5K	2 WATT	+10%	1
R3345	12-2-13111	707	RESISTOR	11K	2 WATT	+5%	1
R3344	12-2-13111	741	RESISTOR	1.5K	2 WATT	+10%	2
R3343	620592	176	RESISTOR ADJUSTABLE	25K	2 WATT	+10%	1

SYMBOL	DRAWING NO.	PC NO.	NOMENCLATURE	VALUE	RATING	TOL.	NO. REQ.
R3342	12-2-13111	254	RESISTOR	27K	1/2 WATT	+5%	1
R3341	12-2-13111	220	RESISTOR	1K	1/2 WATT	+5%	1
R3340	12-2-13111	286	RESISTOR	18K	1/2 WATT	+10%	1
R3339	12-2-13110	9273	RESISTOR ADJUSTABLE	.1 MEG	2 WATT	+10%	1
R3338	12-2-13111	261	RESISTOR	51K	1/2 WATT	+5%	1
R3337	12-2-13110	7300	RESISTOR	18K	1/2 WATT	+1%	2
R3335	12-2-13111	*	RESISTOR	0-510 OHMS	1/2 WATT	+5%	1
R3334	12-2-13111	478	RESISTOR	15K	1 WATT	+5%	1
R3333							1
R3332	12-2-13110	7365	RESISTOR	2.2K	1/2 WATT	+1%	4
R3331							1
R3328	12-2-13111	454	RESISTOR	1.5K	1 WATT	+5%	1
R3327	12-2-13111	237	RESISTOR	5.1K	1/2 WATT	+5%	1
R3326	12-2-13110	7381	RESISTOR	20K	1/2 WATT	+1%	1
R3325	12-2-13111	283	RESISTOR	10K	1/2 WATT	+5%	1
R3324	12-2-13111	1170	RESISTOR	750 OHMS	1/2 WATT	+5%	1
R3323	12-2-13111	452	RESISTOR	1.2 K	1 WATT	+5%	1
R3322	12-2-13111	517	RESISTOR	10 K	1 WATT	+10%	1
R3321	12-2-13111	354	RESISTOR	.22 MEG	1/2 WATT	+10%	1
R3320	12-2-13111	261	RESISTOR	.82 MEG	1/2 WATT	+10%	1
R3319	12-2-13111	309	RESISTOR	.30 MEG	1/2 WATT	+5%	1
R3318	12-2-13111	264	RESISTOR	.15 MEG	1/2 WATT	+10%	1
R3317	12-2-13111	237	RESISTOR	5.1 K	1/2 WATT	+5%	1
R3316	12-2-13111	351	RESISTOR	.12 MEG	1/2 WATT	+10%	1
R3315	12-2-13111	350	RESISTOR	.1 MEG	1/2 WATT	+10%	1
R3314	12-2-13111	213	RESISTOR	510 OHMS	1/2 WATT	+5%	1
R3313	12-2-13111	354	RESISTOR	.22 MEG	1/2 WATT	+10%	1
R3312	12-2-13111	350	RESISTOR	.1 MEG	1/2 WATT	+10%	1
R3311	12-2-13111	314	RESISTOR	.47 MEG	1/2 WATT	+5%	1
R3310	12-2-13111	203	RESISTOR	10 K	1/2 WATT	+10%	1
R3309	12-2-13111	350	RESISTOR	.1 MEG	1/2 WATT	+10%	1
R3308	12-2-13111	256	RESISTOR	.33 MEG	1/2 WATT	+10%	1
R3307	12-2-13111	222	RESISTOR	1.2 K	1/2 WATT	+5%	1
R3306	12-2-13111	254	RESISTOR	.22 MEG	1/2 WATT	+10%	1
R3305	12-2-13111	302	RESISTOR	.15 MEG	1/2 WATT	+5%	1
R3304	12-2-13111	314	RESISTOR	.47 MEG	1/2 WATT	+5%	1
R3303	12-2-13111	595	RESISTOR	.10 MEG	1 WATT	+10%	1
R3302	12-2-13111	207	RESISTOR	2.2 K	1/2 WATT	+10%	1
R3301	12-2-13111	350	RESISTOR	.10 MEG	1/2 WATT	+10%	1
C3329	12-2-13100	9541	CAPACITOR	.1 MFD	300 WVDC	+20%	1
C3328	12-2-13100	9335	CAPACITOR	1.0 MFD	100 WVDC	+10%	2
C3327							1
C3325	12-2-13100	9432	CAPACITOR	.47 MFD	200 WVDC	+10%	2
C3324	12-2-13100	9501	CAPACITOR	.0015 MFD	300 WVDC	+10%	1
C3323	12-2-13100	9499	CAPACITOR	.001 MFD	300 WVDC	+10%	1
C3321	12-2-13100	9567	CAPACITOR	.47 MFD	300 WVDC	+10%	2
C3320	12-2-13100	9547	CAPACITOR	.01 MFD	300 WVDC	+10%	1
C3319	12-2-13100	9541	CAPACITOR	.1 MFD	300 WVDC	+20%	1
C3318	12-2-13100	9267	CAPACITOR	.047 MFD	100 WVDC	+10%	2
C3317	12-2-13100	9503	CAPACITOR	.0022 MFD	300 WVDC	+10%	1
C3316	12-2-13100	9503	CAPACITOR	.0022 MFD	300 WVDC	+10%	1
C3315	12-2-13100	*	CAPACITOR	100 WVDC	+10%	1	
C3314	12-2-13100	*	CAPACITOR	100 WVDC	+10%	1	
C3313	12-2-13100	*	CAPACITOR	100 WVDC	+10%	1	
C3312	12-2-13100	*	CAPACITOR	100 WVDC	+10%	1	
C3311	12-2-13100	9499	CAPACITOR	.001 MFD	300 WVDC	+10%	1
C3310	12-2-13100	9571	CAPACITOR	.011 MFD	300 WVDC	+5%	1
C3309							1
C3308	12-2-13100	9267	CAPACITOR	.047 MFD	300 WVDC	+10%	2
C3307	12-2-13100	9539	CAPACITOR	.047 MFD	300 WVDC	+20%	1
C3306	12-2-13100	9537	CAPACITOR	.022 MFD	300 WVDC	+20%	1
C3305	12-2-13100	9539	CAPACITOR	.047 MFD	300 WVDC	+20%	1
C3304	12-2-13100	9503	CAPACITOR	.0022	300 WVDC	+10%	1
C3303	12-2-13100	9539	CAPACITOR	.047 MFD	300 WVDC	+20%	2
C3302	12-2-13100	9541	CAPACITOR	.1 MFD	300 WVDC	+20%	1

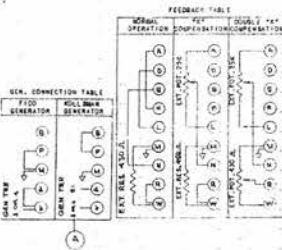

FRAME RECEPTACLE WIRE CONNECTIONS

- A D E F L N H M B
- CONNECTIONS TO FEEDBACK POT. SEE FEEDBACK TABLE AT LEFT
- B CONNECTIONS TO BATE GENERATOR SEE GEN. CONNECTION TABLE AT LEFT
- H INPUT SIGNAL (400 CYCLE)
- C OUTPUT SIGNAL 60~120 SERVO AMPLIFIER
- J INPUT, FILAMENT SUPPLY (6.3V., 60 ~ 40 AMP.)
- U INPUT, COMMON RETURN
- Z INPUT, 12 VOLTS 400 CYCLE A.C. REFERENCE

- U INPUT B1 +250 VOLTS REGULATED D.C., .004 AMPS
- V INPUT B2 +250 VOLTS REGULATED D.C., .002 AMPS
- X INPUT, (FEEDBACK FROM MOTOR BINDING)
- Y R<sub>1</sub> INPUT, REFERENCE 115 VOLTS 60 CYCLE A.C. 0 AMP.
- Z OUTPUT TEST INDICATOR FOR SERVO CONTROL
- W INPUT SERVO AMPLIFIER TEST SIGNAL (CONNECT TO COMMON RETURN ON FRAME RECEPTACLE IF NOT USED)

- NOTES:
- 1. ○ = TERMINAL POINTS ON TERMINAL BOARD
  - 2. ⊕ = CHASSIS CONNECTION
  - 3. TEST IN ACCORDANCE WITH BUORD 5K 282619
  - 4. ⊕ = SHIELDED WIRE
  - 5. ALL SHIELDED WRES GROUND AT ONE END UNLESS OTHERWISE SHOWN.
  - 6. HEAVY LINE INDICATES SIGNAL FLOW.

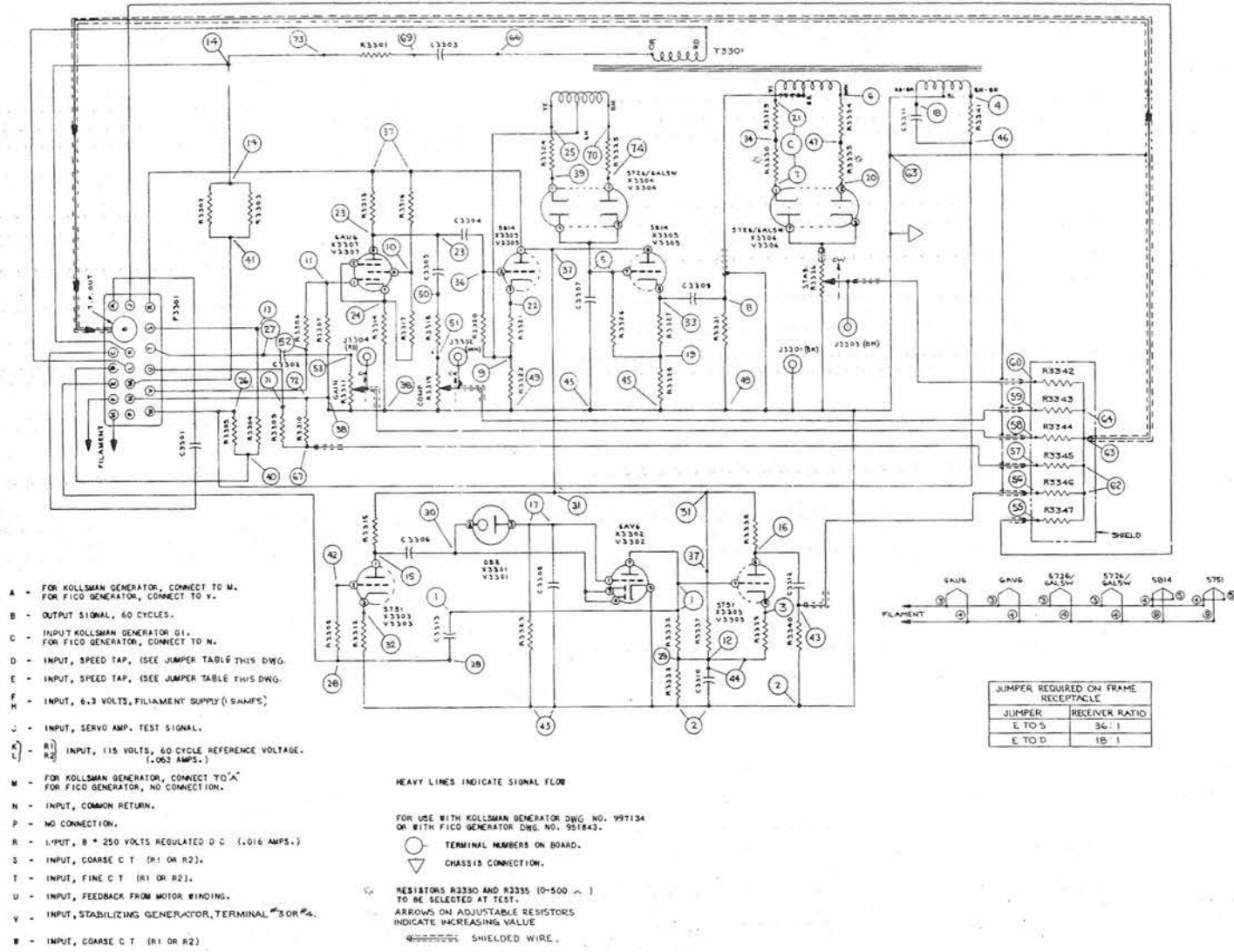

Figure 81. Servo Control, Double-Speed, Schematic Diagram (Unit 3305)

Table 58  
UNIT 3305 - RESISTANCE AND VOLTAGE TESTS

BuOrd Dwg 980422

## Resistance Tests

Terminals	Normal	Minimum	Maximum
1	704K	670K	738K
2	0	0	0
3	28.3K	26.9K	29.7K
4	30 ohms	27 ohms	33 ohms
5	492K	444K	540K
6	150K	145K	155K
7	172K	167K	177K
8	150K	145K	155K
9	22K	21K	23K
10	42K	41K	43K
11	22K	21K	23K
12	21K	20K	22K
13	141K	134K	148K
14	Infinite	---	---
15	276K	262K	290K
16	446K	401K	491K
17	1M	0.95M	1.05M
18	30 ohms	27 ohms	33 ohms
19	22K	21K	23K
20	172K	167K	177K
21	150K	145K	155K
22	24.2K	22.8K	25.2K
23	176K	161K	191K
24	750 ohms	713 ohms	787 ohms
25	22K	21K	23K
26	47K	44.6K	49.4K
27	Infinite	---	---
28	---	---	---
29	21K	20K	22K
30	Infinite	Infinite	Infinite
31	56K	53K	59K
32	9.1K	8.6K	9.6K
33	24.2K	22.8K	25.2K
34	172K	167K	177K
36	492K	444K	540K
37	56K	53K	59K
38	0	0	0
39	44K	41.8K	46.2K
40	94K	89.3K	98.7K
41	Infinite	---	---
42	Infinite	---	---
43	.74M	.67M	.81M
44	21K	20K	22K
45	0	0	0

Table 58 (Cont'd)  
UNIT 3305 - RESISTANCE AND VOLTAGE TESTS

BuOrd Dwg 980422  
Resistance Tests

Terminals	Normal	Minimum	Maximum
46	47K	44.6K	49.4K
47	172K	167K	177K
48	Infinite	Infinite	Infinite
49	0	0	0
50	2.5M	2.2M	2.8M
51	1M	0.8M	1.2M
52	242K	230K	254K
53	100K	90K	110K
55	2.66M	2.62M	2.70M
56	0.74M	0.67M	0.81M
57	1K	0.95K	1.05K
58	0	0	0
59	0	0	0
60	0	0	0
62	0.47M	0.45M	0.49M
63	0	0	0
64	0.47M	0.45M	0.49M
66	Infinite	---	---
67	1K	0.95K	1.05K
68	Infinite	---	---
69	Infinite	---	---
70	22K	21K	23K
71	52K	49K	55K
72	0	0	0
73	Infinite	---	---
74	44K	41.8K	46.2K

Turn all potentiometers fully counterclockwise.

DC Voltage Tests

Terminals	Volts	Terminals	Volts
1	+18	22	+82
3	+50	23	+105
5	+74	24	+3.1
6	0	25	+74
7	0	31	+235
9	+74	32	+2.6
10	+120	33	+82
11	0	36	+50
15	+180	43	0
16	+235	44	+50
17	0	51	+18
19	+74	70	+74

Turn all potentiometers fully counterclockwise. Readings may vary  $\pm 10$  per cent about values given.

Table 59  
UNIT 3305 - PARTS LIST

SYMBOL	DRAWING NO	PC NO	NOMENCLATURE	VALUE	RATING	TOL	NO REQ
T3301	SK137557 (595753)		TRANSFORMER				1
P3301	12-2-7113	6340	CONNECTOR, PLUG				1
J3304	12-2-7113	3001	CONNECTOR, RECEPTACLE				1
J3303	12-2-7113	3003	CONNECTOR, RECEPTACLE				1
J3302	12-2-7113	3000	CONNECTOR, RECEPTACLE				1
J3301	12-2-7113	3002	CONNECTOR, RECEPTACLE				1
Y3307	16-T-56203	50	ELECT. TUBE, 6AU6				1
Y3306	16-T-75726		ELECT. TUBE, 5726/6AL5W				1
Y3305	16-T-75814		ELECT. TUBE, 5814				1
Y3304	16-T-75726		ELECT. TUBE, 5726/6AL5W				1
Y3303	12-2-13005	574	ELECT. TUBE, 5751 DBL. TRI.				1
Y3302	16-T-56203	60	ELECT. TUBE, 6AY6				1
Y3301	16-T-52001	5	ELECT. TUBE, 0B2				1
X3307	12-2-7510	113	SOCKET, ELECT. TUBE, 7 PIN				1
X3306	12-2-7510	113	SOCKET, ELECT. TUBE, 7 PIN				1
X3305	12-2-7510	114	SOCKET, ELECT. TUBE, 9 PIN				1
X3304	12-2-7510	113	SOCKET, ELECT. TUBE, 7 PIN				1
X3303	12-2-7510	114	SOCKET, ELECT. TUBE, 9 PIN				1
X3302	12-2-7510	113	SOCKET, ELECT. TUBE, 7 PIN				1
X3301	12-2-7510	113	SOCKET, ELECT. TUBE, 7 PIN				1
R3347							
R3346							
R3345							
R3344	625225	3	RESISTOR	2.2 M	1/2 WATT	±10%	6
R3343							
R3342							
R3341	12-2-13111	260	RESISTOR, FIX. COMP.	47 K	1/2 WATT	±5%	1
R3340	12-2-13111	362	RESISTOR, FIX. COMP.	1 M	1/2 WATT	±10%	1
R3339	12-2-13111	235	RESISTOR, FIX. COMP.	4.3 K	1/2 WATT	±5%	1
R3338	12-2-13111	357	RESISTOR, FIX. COMP.	390 K	1/2 WATT	±10%	1
R3337	12-2-13111	529	RESISTOR, FIX. COMP.	100 K	1 WATT	±5%	1
R3336	12-2-13110	92.74	RESISTOR, ADJ. W.W.	1 M	2 WATT	±20%	1
R3335	625463	*	RESISTOR, FIX. COMP.	0-500 Ω	1/2 WATT	±5%	1
R3334	62522.5	10	RESISTOR,	22 K	WATT	±1%	1
R3333	12-2-13111	483	RESISTOR, FIX. COMP.	24 K	1 WATT	±5%	1
R3332	12-2-13111	318	RESISTOR, FIX. COMP.	680 K	1/2 WATT	±5%	1
R3331	12-2-13111	302	RESISTOR, FIX. COMP.	150 K	1 WATT	±5%	1
R3330	625463	*	RESISTOR, FIX. COMP.	0-500 Ω	WATT	±5%	1
R3329	62522.5	10	RESISTOR,	22 K	WATT	±1%	1
R3328	12-2-13111	252	RESISTOR, FIX. COMP.	22 K	WATT	±5%	1
R3327	12-2-13111	228	RESISTOR, FIX. COMP.	2.2 K	WATT	±5%	1
R3326	12-2-13111	358	RESISTOR, FIX. COMP.	470 K	WATT	±10%	1
R3325							
R3324	62522.5	10	RESISTOR,	22 K	WATT	±1%	2
R3323	12-2-13111	322	RESISTOR, FIX. COMP.	1 M	WATT	±5%	1
R3322	12-2-13111	252	RESISTOR, FIX. COMP.	22 K	WATT	±5%	1
R3321	12-2-13111	228	RESISTOR, FIX. COMP.	2.2 K	WATT	±5%	1
R3320	12-2-13111	358	RESISTOR, FIX. COMP.	470 K	WATT	±10%	1
R3319	12-2-13110	92.74	RESISTOR, ADJ. W.W.	1 M	2 WATT	±20%	1
R3318	12-2-13111	326	RESISTOR, FIX. COMP.	1.5 M	1/2 WATT	±5%	1
R3317	12-2-13111	292	RESISTOR, FIX. COMP.	56 K	WATT	±5%	1
R3316	12-2-13111	260	RESISTOR, FIX. COMP.	47 K	WATT	±5%	1
R3315	12-2-13111	306	RESISTOR, FIX. COMP.	220 K	WATT	±5%	1
R3314	12-2-13111	217	RESISTOR, FIX. COMP.	750 Ω	WATT	±5%	1
R3313	12-2-13111	351	RESISTOR, FIX. COMP.	120 K	WATT	±10%	1
R3312	12-2-13111	243	RESISTOR, FIX. COMP.	9.1 K	WATT	±5%	1
R3311	12-2-13110	92.73	RESISTOR, ADJ. W.W.	100 K	2 WATT	±0%	1
R3310	12-2-13111	220	RESISTOR, FIX. COMP.	1 K	1/2 WATT	±5%	1
R3309	12-2-13111	261	RESISTOR, FIX. COMP.	51 K	WATT	±5%	1
R3308	12-2-13111	358	RESISTOR, FIX. COMP.	470 K	WATT	±10%	1
R3307	12-2-13111	252	RESISTOR, FIX. COMP.	22 K	WATT	±5%	1
R3306	12-2-13111	306	RESISTOR, FIX. COMP.	220 K	WATT	±5%	1
R3305							
R3304	12-2-13111	260	RESISTOR, FIX. COMP.	47 K	WATT	±5%	2
R3303							
R3302	12-2-13111	741	RESISTOR, FIX. COMP.	1.5 K	2 WATT	±10%	2
R3301	12-2-13111	752	RESISTOR, FIX. COMP.	12 K	2 WATT	±10%	1
C3313	1C-C-31903	1089	CAPACITOR, FIXED MECA	2200MFD	500VDC	±5%	1
C3312	12-2-13100	9551	CAPACITOR, FIXED PAPER	.022MFD	300VDC	±10%	1
C3311	12-2-13100	9267	CAPACITOR, FIXED PAPER	.047MFD	100VDC	±10%	1
C3310	12-2-13100	9449	CAPACITOR, FIXED PAPER	.051MFD	200VDC	±5%	1
C3309	12-2-13100	9329	CAPACITOR, FIXED PAPER	.33 MFD	100VDC	±10%	1
C3308	12-2-13100	9394	CAPACITOR, FIXED PAPER	.1MFD	200VDC	±20%	1
C3307	12-2-13100	9329	CAPACITOR, FIXED PAPER	.33 MFD	100VDC	±10%	1
C3306	16-C-32720	7533	CAPACITOR, FIXED MICA	9000MFD	500VDC	±5%	1
C3305	12-2-13100	9539	CAPACITOR, FIXED PAPER	.047MFD	300VDC	±20%	1
C3304	12-2-13100	9559	CAPACITOR, FIXED PAPER	.1MFD	300VDC	±10%	1
C3303	12-2-13100	9476	CAPACITOR, FIXED PAPER	.1MFD	200VDC	±10%	1
C3302	12-2-13100	9259	CAPACITOR, FIXED PAPER	.01MFD	100VDC	±10%	1
C3301	12-2-13101	307	CAPACITOR, FIXED PAPER	.1MFD	400VDC	±2%	1

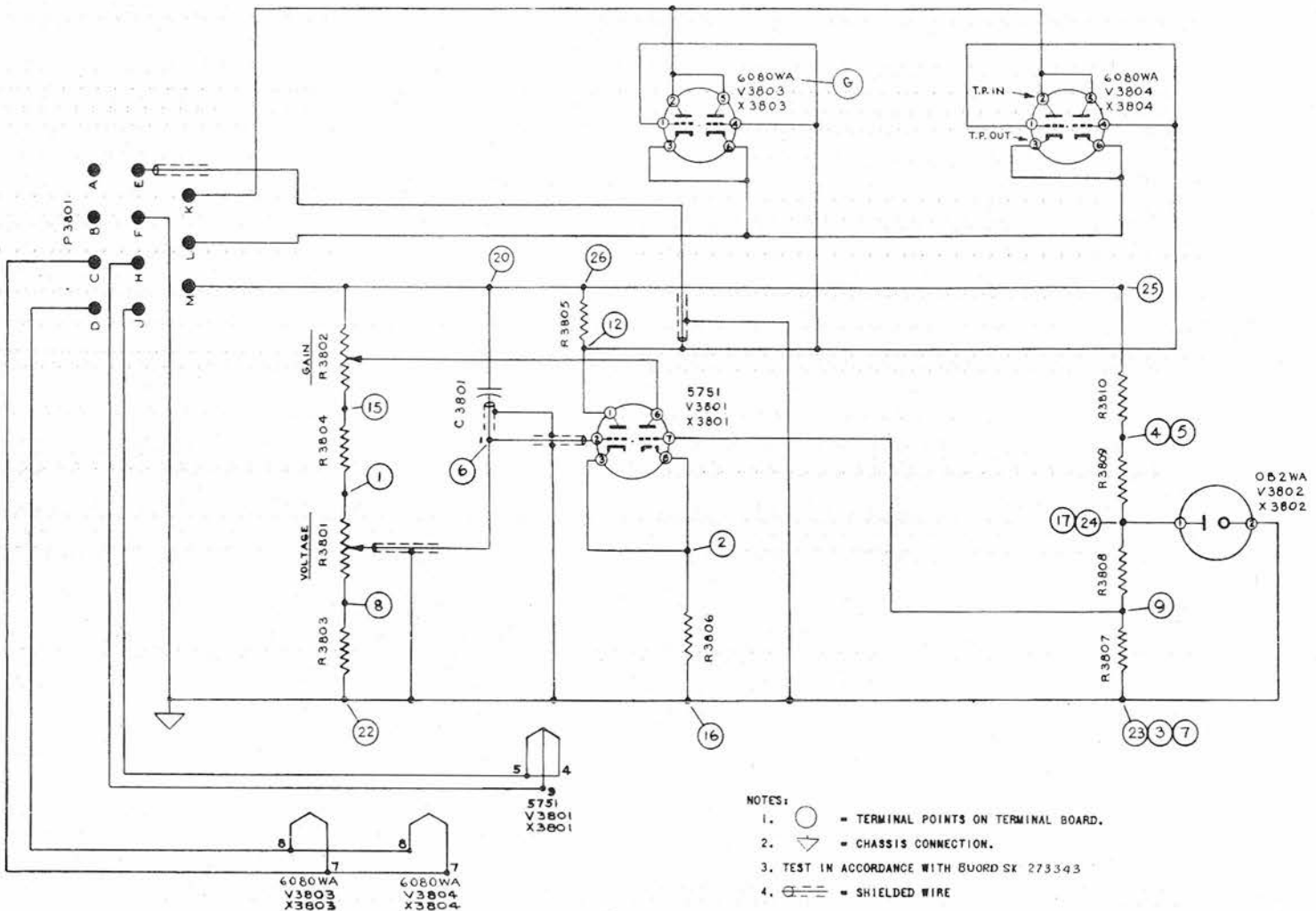

Figure 82. +250-v DC Power Supply, Schematic Diagram (Unit 3803)

Table 60  
UNIT 3803 - RESISTANCE VOLTAGE TESTS

BuOrd Dwg 951989  
Resistance Tests

Terminals	Normal	Minimum	Maximum
1	9.4K	8.89K	9.83K
2	51K	48.45K	53.55K
3	0	0	0
4	34.8K	32.37K	36.95K
5	34.8K	32.37K	36.95K
7	0	0	0
8	7.14K	6.78K	7.5K
9	32.89K	31.13K	34.65K
12	132.07K	119.82K	144.30K
15	17.45K	16.55K	18.34K
16	0	0	0
17	36.67K	34.34K	38.99K
20	32.07K	29.82K	34.30K
22	0	0	0
23	0	0	0
24	36.67K	34.34K	38.99K
25	32.07K	29.82K	34.30K
26	32.07K	29.82K	34.30K

DC Voltage Tests

Terminals	Volts	Terminals	Volts
1	+57	9	+52
2	+53	12	+232
4	+183	15	+113
6	+52	17	+110
8	+40		

Voltage tolerance 5 per cent.

Table 61  
UNIT 3803 - PARTS LIST

SYMBOL	DRAWING NO	PC NO	NOMENCLATURE	VALUE	RATING	TOL	NP REQ
X3804 X3803	12-Z-7510	117	SOCKET; ELECTRON TUBE, 8 PIN, JAN TS101P02				2
X3802	12-Z-7510	113	SOCKET; ELECTRON TUBE, 7 PIN, JAN TYPE TS102P01				1
X3801	12-Z-7510	114	SOCKET; ELECTRON TUBE, 9 PIN, JAN TYPE TS103P01				1
V3804 V3803	16-T-76080	85	TUBE; ELECTRON; 6080WA TWIN TRIODE 8 PIN				2
V3802	16-T-52001	8	TUBE; ELECTRON; 082WA MINIATURE, 7 PIN				1
V3801	12-Z-13005	574	TUBE; ELECTRON; 5751 MINIATURE TRIODE, 9 PIN				1
P3801	12-Z-7113	6301	CONNECTOR; PLUG, 11 LUG, PNL TYPE, MTG. STUDS 1.562 C/C				1
R3810 R3809	12-Z-13111	702	RESISTOR; FIXED COMPOSITION .405 DIA. X 1.41 LG.	6.8 K	2 WATT	±5%	2
R3808	12-Z-13111	261	RESISTOR; FIXED COMPOSITION .175 DIA. X .406 LG.	51 K	1/2 WATT	±5%	1
R3807	12-Z-13111	260	RESISTOR; FIXED COMPOSITION .175 DIA. X .406 LG.	47 K	1/2 WATT	±5%	1
R3806	12-Z-13111	261	RESISTOR; FIXED COMPOSITION .175 DIA. X .406 LG.	51 K	1/2 WATT	±5%	1
R3805	12-Z-13111	298	RESISTOR; FIXED COMPOSITION .175 DIA. X .406 LG.	100 K	1/2 WATT	±5%	1
R3804	12-Z-13111	244	RESISTOR; FIXED COMPOSITION .175 DIA. X .406 LG.	10 K	1/2 WATT	±5%	1
R3803	12-Z-13111	241	RESISTOR; FIXED COMPOSITION .175 DIA. X .406 LG.	7.5 K	1/2 WATT	±5%	1
R3802	16-R-87749	4560	RESISTOR; VARIABLE COMPOSITION 1-1/16 DIA. X 9/16 D.	25 K	2 WATT	±10%	1
R3801	12-Z-13110	9031	RESISTOR; VARIABLE COMPOSITION 1-1/16 DIA. X 9/16 D.	2.5 K	2 WATT	±10%	1
C3801	16-C-32720	7533	CAPACITOR; FIXED MICA, BIELEC. 53/64 X 53/64 X 11/32	2100 MMFD	500 WVDC	±5%	1

FRAME RECEPTACLE WIRING CONNECTIONS

- A. NO CONNECTION
- B. NO CONNECTION
- C) 6.3-VOLT FILAMENT, 60 CYCLE AC { AT 2.5 AMPS INPUT FOR DWG. 951989-1
- D) { AT 5.0 AMPS INPUT FOR DWG. 951989-2 (DC POTENTIAL + 250V.)
- E. GRID CONTROL (FOR USE WITH EXTERNAL CURRENT BOOSTER, 15 6A37G TUBES MAX.)
- F. COMMON RETURN
- H) 6.3-VOLT FILAMENT, 60-CYCLE AC, AT 0.35 AMPS INPUT (DC POTENTIAL - GND)
- K. +350-VOLT REGULATED DC INPUT { .25 AMPS MAX. FOR DWG. 951989-1
- { .50 AMPS MAX. FOR DWG. 951989-2
- \* L. +250-VOLT DC OUTPUT { AT 0.225 AMPS MAX. FOR DWG. 951989-1
- { AT 0.475 AMPS MAX. FOR DWG. 951989-2
- \* M. +250-VOLT REGULATOR \* L AND M TIED TOGETHER AT DISTRIBUTION BUSS



Table 62

## UNIT 3804 - RESISTANCE AND VOLTAGE TESTS

BuOrd Dwg 979772

## Resistance Tests

Turn voltage potentiometer fully counterclockwise.

Terminals	Normal	Minimum	Maximum
2	100K	95K	105K
3	4.12K	3.92K	4.32K
4,6	25.6K	23.3K	27.5K
8	100K	95K	105K
9	4.12K	3.92K	4.32K
10	25.6K	23.3K	27.5K
16	0		
17	23.7K	21.5K	25.9K
18	76.6K	71.7K	81.1K
22	151K	143K	159K
23	0		
24	23.7K	21.5K	25.9K
27	0		
A,B,M,N	Infinite	---	---
P	25.6K	23.3K	27.5K
1 to 2 on Relay K3801	3600	3500	3700
H to F on P3801	Infinite	---	---

## DC Voltage Tests

Measure voltages with VTVM

Terminals	Voltage $\pm 20\%$	Terminals	Voltage $\pm 20\%$
2	-16	16	0
3	-18.5	17,18	-75
4	-105 ( $\pm 1$ volt)	22	-16
6	-75	23	0
8	-16	24	-75
9	-18.5	27	0
10	-105 ( $\pm 1$ volt)	L	67
		R	55

With the supply operating under normal conditions, a resistance check between pins H and F must read zero, indicating that the relay contacts are closed.

If the line voltage is decreased until the supply output falls to -90 volts, a resistance check between pins H and F will show infinite resistance, indicating that the relay contacts are open.

Table 63  
UNIT 3804 - PARTS LIST

SYMBOL	DRAWING NO	PC NO	NOMENCLATURE	VALUE	RATING	TOL	NO REQ
X3806	12-Z-7510	117	SOCKET, ELECTRON TUBE, 8 PIN JAN TYPE TS101P02				1
X3805	12-Z-7510	117	SOCKET, ELECTRON TUBE, 8 PIN JAN TYPE TS101P02				1
X3804	12-Z-7510	114	SOCKET, ELECTRON TUBE, 9 PIN JAN TYPE TS103P01				1
X3803	12-Z-7510	113	SOCKET, ELECTRON TUBE, 7 PIN JAN TYPE TS102P01				1
X3802	12-Z-7510	113	SOCKET, ELECTRON TUBE, 7 PIN JAN TYPE TS102P01				1
X3801	12-Z-7510	113	SOCKET, ELECTRON TUBE, 7 PIN JAN TYPE TS102P01				1
V3806	16-T-53030		ELECTRON TUBE, 0A3 DIODE VOLTAGE REGULATOR 6 PIN				1
V3805	16-T-56202		ELECTRON TUBE, 6080WA RECEIV. TWIN TRIODE VOLTAGE REG., 9 PIN				1
V3804	12-Z-13005	574	ELECTRON TUBE, 5751 DBL-TRI VOLTAGE AMPLIFIER, 9 PIN				1
V3803	16-T-75651		ELECTRON TUBE, 5651WA VOLTAGE REGULATOR (MINIA.VR-75) 7 PIN				1
V3802	16-T-56840	50	ELECTRON TUBE, 6X4W MINIA.TYPE DUO DI VAC. RECTIFIER 7 PIN				1
V3801	16-T-56840	50	ELECTRON TUBE, 6X4W MINIA.TYPE DUO DI VAC. RECTIFIER 7 PIN				1
P3801	12-Z-7113	6307	CONNECTOR, PLUG, 14 LUG CONTACT MOUNTING STUDS 1.938" C/C				1
K3801	1149374		RELAY, ARMATURE; SPST, NO; 3600 OHM COIL; HS. STEEL CASE	9 MA	30 R.C.V.	+ 10%	1
R3809 R3808	16-R-87749	4560	RESISTOR, VARIABLE, COMP. 25000 OHMS, + 10%, 2W, LIN. PAPER.	25 K	2 WATT	+ 10%	2
R3806	12-Z-13111	261	RESISTOR, FIXED COMPOSITION .406 LG X .175 DIA.	51 K	1/2 WATT	+ 5%	1
R3805	12-Z-13111	248	RESISTOR, FIXED COMPOSITION .406 LG X .175 DIA.	15 K	1/2 WATT	+ 5%	1
R3804	12-Z-13111	289	RESISTOR, FIXED COMPOSITION .406 LG X .175 DIA.	33 K	1/2 WATT	+ 10%	1
R3803	12-Z-13111	235	RESISTOR, FIXED COMPOSITION .406 LG X .175 DIA.	4.3 K	1/2 WATT	+ 5%	1
R3802	12-Z-13111	298	RESISTOR, FIXED COMPOSITION .406 LG X .175 DIA.	100 K	1/2 WATT	+ 5%	1
R3801	12-Z-13111	261	RESISTOR, FIXED COMPOSITION .406 LG X .175 DIA.	51 K	1/2 WATT	+ 5%	1
C3802	16-C-49981	9967	CAPACITOR, FIXED, PAPER, DIELEC. JAN TYPE CPT0E1PF 405 V	4 MFD.	600 WVDC	+ 20% - 10%	1
C3801	16-C-31085	3689	CAPACITOR, FIXED MICA DIELECT. 53/64 X 53/64 X 9/32	.001 MFD	500 WVDC	+ 5%	1

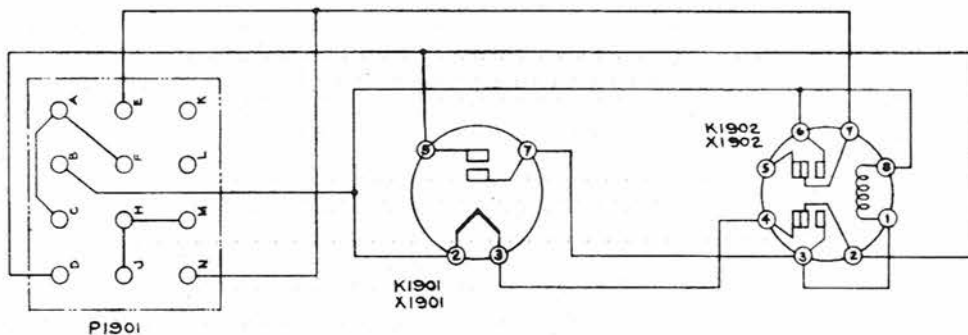

DRAWING NUMBERS IN TABLE ARE FOR REFERENCE ONLY

SYMBOL	DRAWING NO	PC NO	NOMENCLATURE	VALUE	RATING	TOL	NO REQ
X1902 X1901	12-Z-7510	117	SOCKET, ELECTRON TUBE; JAN TYPE TS1Q1P02				2
P1901	12-Z-7113	6303	CONNECTOR PLUG; PHL. TYPE; 12 LUGS NO COAX; 1 5/16" L. Ø. x 1 1/8" HD.				1
K1902	12-Z-13001	9277	RELAY	15 AMP	115 VOLTS		1
K1901	12-Z-13001	9109	RELAY, THERMAL 6AMP, 117V HEATER V. -30±5 SEC. OPERATING	6 AMP	250 VOLTS		1

- A } INPUT
- B } 115-VOLT-60 CYCLE SUPPLY.
- C } INTERLOCK \*
- D } -106 VOLT POWER SUPPLY RELAY.
- E } OUTPUT TO  
PRI. LEAD OF PLATE TRANSFORMER FOR +350 VOLT POWER SUPPLY (SEE NOTE.)
- F } STAND BY SWITCH. \*
- J } SAFETY INTERLOCK (FROM +350-VOLT POWER SUPPLY.)
- K } NO CONNECTION.
- L } NO CONNECTION.
- M } SINGLE PHASING RELAY (COIL CONNECTION.)
- N }

\*WHEN NOT USED, CONNECT JUMPER ACROSS TERMINALS.

NOTE: RELAY CONTACT RATING IS 15-AMP MAX., NON-INDUCTIVE

TEST IN ACCORDANCE WITH BUORD SK 273365

Figure 84. Time Delay Control, Schematic Diagram (Unit 1903)

Table 64

## UNIT 1903 (TIME DELAY CONTROL)

BuOrd Dwg 979577

## Resistance Tests

Remove the two relays from their sockets.

Between Terminals	Resistance
A and E	INF
A and B	INF
B and E	INF
Replace relay K1902 only, and continue tests on socket X1901.	
1 and 8	400 $\pm$ 10%
3 and 4	INF
5 and 6	INF

Observe the physical condition of the relay mechanism housed in K1901. The contacts of the relay should be separated and its finished surfaces clean.

## TIME DELAY TEST

Reinsert the two relays. With a test jumper, short together terminals C and D, and with another jumper, terminals H and F. Obtain a 115-volt 60-cycle power source, and connect it across terminals A and B. Connect the clip leads of an analyzer across terminals C and N on the plug connector. Energize the unit, simultaneously noting the exact time the power is applied. After 30 seconds, the measured voltage on the analyzer should read 115 volts.

De-energize the unit. Remove the clip leads from A and E, and connect them across terminals C and N. Energize the unit again, and complete the test as directed for terminals A and E above.

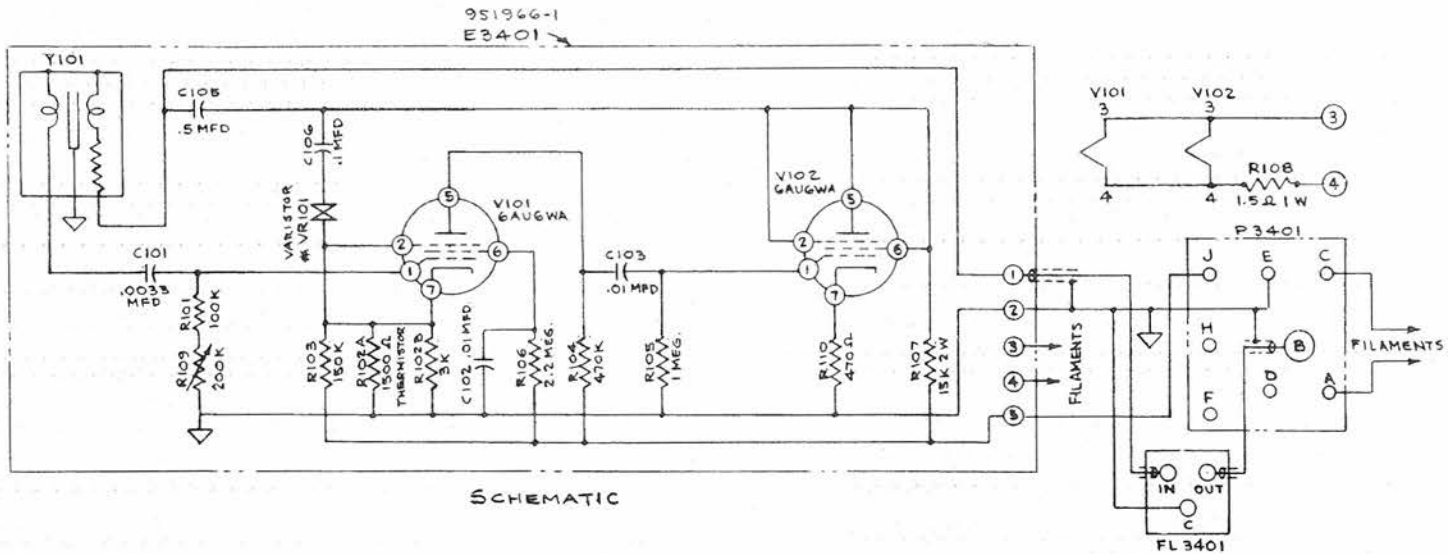

DRAWING NUMBERS IN THIS TABLE ARE FOR REFERENCE ONLY

SYMBOL	DRAWING NO	PC NO	NOMENCLATURE	VALUE	RATING	TOL	QUAN
P3401	12-7-7113	6300	PLUG CONNECTOR				1
FL3401	52-876		FILTER				1
E3401	951966		FREQUENCY STANDARD				1

NOTES:

1. ○ TERMINAL LETTERS ON BOARD AND SOCKET
2. ▽ COMMON RETURN
3. TEST IN ACCORDANCE WITH BUORD SK 285702

RECEPTICAL WIRING CONNECTIONS

- A) INPUT-HEATER FILAMENT 6.3 VOLTS
- C) 60 CYCLES 0.6 AMPS
- B - OUTPUT
- D - NO CONNECTION
- E - INPUT COMMON RETURN
- F - NO CONNECTION
- H - NO CONNECTION
- J - INPUT B+ 250 VOLTS, REGULATED  
D C , .010 AMPS

Figure 85. Tuning Fork Oscillator, 400-cycles, Schematic Diagram  
(Unit 3401)

Table 65

## UNIT 3401 (400-CYCLE TUNING FORK OSCILLATOR)

BuOrd Dwg 1372162

## Resistance Tests

Terminal	Normal	Minimum	Maximum
5 to V101-5	470K	423K	517K
5 to V101-6	2.2M	2.0M	2.4M
V102-1	1M	0.9M	1.1M
5 to V102-6	15K	13.5K	16.5K
V102-7	470	423	517
Across R101	100K	90K	110K

## DC Voltage Tests

Terminal	Volts $\pm 10\%$	Terminal	Volts $\pm 10\%$
V102-2	250	V101-5	225
V102-5	250	V101-6	175
V102-6	250		

detent position. A positive detent action at the correct position automatically will align the potentiometer shaft to its original setting. Then, retighten the locking screw on the control shaft.

### Test Equipment

Accurate test equipment and technical ability are equally important in trouble shooting electronic equipment. In the trouble-shooting tests that follow, two basic test instruments are used: the analyzer volt-ohm meter and the AC VTVM (vacuum-tube voltmeter). Refer to the operation manual for each instrument to be certain that its operation is understood thoroughly.

**Analyzer.** The Weston Analyzer, Model #779, was used for establishing all volt-ohm meter data given in the tables of point-to-point voltages and resistances. However, any reliable volt-ohm meter of 20,000 ohms per volt sensitivity, capable of measuring AC and DC to 1000 volts, will be satisfactory.

**AC VTVM.** The Hewlett Packard VTVM, Model #400-C, was used for establishing all tabulated test data requiring the use of an AC vacuum-tube voltmeter. Any reliable VTVM capable of measuring AC voltages from 0.001 to 300 volts rms will be acceptable.

**WARNING:** The maximum voltage that exists in Computer Mk 48 Mod 1 is +455 volts DC. Contact with voltages of such magnitude can be fatal. Maintenance personnel, therefore, are urged to be always alert when checking energized equipment and to adhere strictly to the rules and regulations pertinent to work on high voltage electrical equipment.

### Unit 3804—Relay Operation Check

This power supply contains a single-pole single-throw relay housed in a steel case. With an analyzer connected between terminals 1 and 2, measure the DC resistance of the armature coil. Its resistance should be about 3600 ohms.

With power off, a resistance check between pins H and F must show infinite resistance, indicating that the relay contacts are open.

With the supply operating under normal conditions, a similar resistance check between pins H and F must read zero, indicating that the relay contacts are closed.

If the line voltage is decreased until the supply output falls to -90 volts, a resistance check between pins H and F will show infinite resistance, indicating that the relay contacts are open.

### TRANSFORMERS AND CHOKES

A list of the transformers and chokes used in this computer are arranged in table 66 according to their BuOrd drawing numbers. Positive identification of a transformer or choke can be made only by referring to its BuOrd number. Units that may be readily interchanged will have identical BuOrd numbers.

The resistance tests of table 67 and the voltage tests of table 68 are used in testing the transformers and chokes. When conducting these tests, use a 20,000 ohms per volt analyzer for both resistance and voltage measurements. For critical measurements, however, use an AC VTVM.

When testing a transformer, conduct the voltage tests while the transformer is working under typical load conditions. Take each measurement in the step-by-step manner shown in the tests. If the transformer is defective, the resistance tests

**Table 66**  
**TRANSFORMERS AND CHOKES REFERENCE INDEX**

BuOrd Dwg	Transformer Unit No	Transformer Designation	Located in Element	BuOrd Test Sketch	Function
595596	1001	T3301	3001, 3011	137433	Step-down
595669	1009	T3305	3301, 3302	137441	Filter
595671	1006	T3303	3301, 3302	137438	400-c control
595753	1008	T3304	3301, 3302, 3304, 3305	137440	60-c sensing
595982	1007	T3301	3301, 3302	137486	400-c sensing
596426	1056	T3401	3401	276623	Filter
596439	1019	T3001	3402	276601	400-c output
979774	1002	T4103	3804 and section 4100	276951	Plate, fil
979835	1003		3804	276952	Filter
980516	1017	T4304	Section 4300	276983	60-c ref
997471	1018	T4303	Section 4300	276985	400-c ref
1225461	1004	T4104	Section 4100	2856009	400-c ref
1225521	1057	T4001	Section 4000	285620	Step-down
1371778	1051	T4101,4102 4301,4302	Sections 4100,4300	285605	Fil

Table 67

## TRANSFORMERS AND CHOKES RESISTANCE MEASUREMENTS

Unit	Winding	Terminals	Resistance $\pm 10\%$
1001	Pri	0 and RED	273
	Sec	BRN and YEL	17.5
	Tertiary	GRN and VIOLET	20.2
1002	Pri	1 and 2	10
	Sec (1)	3 and 5	0.03
	Sec (2)	6 and 8	200
1003	-	1 and 2	140
1004	Pri	1 and 2	0.04
	Sec	3 and 4	0.04
1006	Pri	0 and RED	625
	Sec	BRN and YEL	176
1007	Pri	0 and RED	11
	Sec (1)	WH and VIOLET	270
	Sec (2)	YEL and BRN	270
1008	Pri	0 and RED	190
	Sec (1)	RED, ELK dot and BRN, ELK dot	60
	Sec (2)	BRN and YEL	810
	Sec (3)	VIOLET and WH	155
1009	-	RED and YEL	800
	-	BRN and GRN	1100

**Table 67 (Cont'd)**  
**TRANSFORMERS AND CHOKES RESISTANCE MEASUREMENTS**

Unit	Winding	Terminals	Resistance ±10%
1017	Pri	1 and 2	35
	Sec (1)	3 and 4	22
	Sec (2)	4 and 5	210
	Sec (3)	5 and 6	0.55
	Sec	3 and 6	232
1018	Pri	1 and 2	0.215
	Sec (1)	3 and 4	10.5
	Sec (2)	4 and 5	0.5
	Sec	3 and 5	11
1019	Pri	1 and 3	152
	Sec	4 and 5	0.15
	Sec c-tap	1 and 2	76
1051	Pri	1 and 2	0.8
	Sec (1)	3 and 5	0.005
	Sec (2)	6 and 8	0.005
1056	-	RED and 0	1100

**Table 68**  
**TRANSFORMERS AND CHOKES VOLTAGE MEASUREMENTS**

Unit	Winding	Terminals	Voltage	Tolerance
1001	Pri	0 and RED	60	±10%
	Sec	BRN and YEL	12	±10%
	Tertiary	GRN and VIOLET	5	±10%
1002	Pri	1 and 2	115	
	Sec (1)	3 and 5	6.5	± 0.2 v
	Sec (2)	6 and 8	460	± 10 v
1004	Pri	1 and 2	12	
	Sec	3 and 4	12	± 0.1 v
1006	Pri	0 and RED	120	
	Sec	BRN and YEL	60	± 10%
1007	Pri	0 and RED	12	
	Sec (1)	WH and VIOLET	60	± 10%
	Sec (2)	YEL and BRN	60	± 10%
1008	Pri	0 and RED	30	
	Sec (1)	RED, BLK dot and BRN, BLK dot	5	± 10%
	Sec (2)	BRN and YEL	60	± 10%
	Sec (3)	WH and VIOLET	10	± 10%
1017	Pri	1 and 2	115	
	Sec (1)	3 and 4	25	± 2 v
	Sec (2)	4 and 5	224.5	± 5 v
	Sec (3)	5 and 6	5	± 0.05 v

Table 68 (Cont'd)  
**TRANSFORMERS AND CHOKES VOLTAGE MEASUREMENTS**

Unit	Winding	Terminals	Voltage	Tolerance
1018	Pri	1 and 2	12	
	Sec (1)	3 and 4	92.5	$\pm 1$ v
	Sec (2)	4 and 5	2.5	$\pm .05$ v
1019	Pri	1 and 3	380	$\pm 10\%$
	Sec	4 and 5	12	$\pm 10\%$
1051	Pri	1 and 2	115	$\pm 10\%$
	Sec (1)	3 and 5	6.65	$\pm 10\%$
	Sec (2)	6 and 8	6.65	$\pm 10\%$
1057	Pri	1 and 2	12	---
	Sec	3 and 4	0.12	---

can be used to locate the faulty winding. Replace a defective transformer with a good one of identical drawing number. After the new transformer has been installed, test it for satisfactory operation.

**WARNING:** High voltages are used in these transformers. Death or injury can result if personnel fail to observe the safety precautions pertinent to work on high voltage equipment.

### SERVO CONTROL POTENTIOMETER SETTINGS

Table 69 lists the optimum potentiometer settings for the various servo controls. The settings are made with the servo control removed from the computer. Some settings are made by turning the potentiometer shaft to the end of its clockwise or counterclockwise travel. Other settings are made by turning the potentiometer shaft to an intermediate resistance point, the value of which is expressed as a percentage of the total potentiometer-resistance available. With percentage settings, an ohmmeter is used to measure the total resistance of the potentiometer. Then, by calculation, the specified percentage value is converted into an equivalent resistance value, and the potentiometer shaft locked in at that setting. The potentiometer setting procedure can be summarized as follows:

1. Remove the servo control from the computer.
2. Turn each servo control potentiometer in the direction specified in the table.
3. For percentage setting, measure the resistance between the pertinent test jack and the common-return jack.
4. Set the potentiometer according to the percentage values shown in the

columns. For some potentiometers, rotation of their shafts from maximum counterclockwise to maximum clockwise causes the resistance reading to rise from zero to a maximum reading. Therefore, the correct setting is simply the specified percentage of this maximum value. For other potentiometers, however, rotation of their shafts from minimum to maximum travel will cause the readings to rise from zero to a maximum value (near the midpoint of travel) and then back to a zero reading. With these potentiometers, the correct percentage setting is indicated by a percentage of the maximum reading from the low end of the potentiometer.

For a setting that requires a potentiometer to be set at a maximum reading, the setting is listed as "MAX RES."

For a servo control designated "K COMP," no potentiometer setting is required. This is because the feedback is controlled automatically by an external potentiometer, the internal potentiometer not being used. All other feedback potentiometer settings are at maximum clockwise. All compensation potentiometer settings are at maximum counterclockwise.

### RESOLVER TRIMMING PROCEDURE

When a resolver is being installed as a replacement, the trim components used for the old resolver usually will not be correct for the new one, and must therefore be checked and replaced as necessary. The purpose of the trimming procedures that follow is to duplicate the trim-circuitry requirements needed for optimum accuracy of the computer. Six different procedures are required to cover all of the resolvers in the instrument. The trimming procedures fall into two main sections: four procedures for trimming resolvers paralleled in groups of two, and two procedures for those paralleled in groups of four. The resolvers treated in each procedure are listed in the main title for the procedure.

Table 69

## SERVO CONTROL POTENTIOMETER SETTINGS

Servo Control			Potentiometer Test Jack Settings (Percent)				
Type	Function	Element No ZB	Feedback (Orange)	Gain (Red)	Stab (Brown)	Err Red (Green)	Comp (White)
Computing Velocity- Lag Unit 3301	Ph	4103	MAX CW	MAX RES	60%	--	--
	Es	4107	K COMP	MAX RES	15%	--	--
	OR	4108	K COMP	MAX RES	30%	--	--
	Et	4109	K COMP	MAX RES	20%	--	--
	Xp	4300	K COMP	MAX RES	32%	--	--
	Yp	4301	K COMP	MAX RES	32%	--	--
	OB	4316	K COMP	35% LOW	68%	--	--
	jB	4104	MAX CW	77% LOW	6.2%	--	--
Computing High- Fidelity Unit 3302	L'	4110	MAX CW	46% LOW	17%	--	--
	Zh	4311	MAX CW	65% LOW	33%	--	--
	(jOB'r' -jB'r')	4314	MAX CW	66% LOW	57%	--	--
	jOB'r'	4315	MAX CW	65% LOW	54%	--	--
Double- Speed Velo- city Lag Unit 3304	R	4102	--	17%	55%	Not Used	--
	Co	4105	--	21%	50%	Not Used	--
Double- Speed High- Fidelity Unit 3305	B'r'	4106	--	35%	48%	--	MAX CCW
	OL'	4112	--	5.6%	20%	--	MAX CCW
	OZh	4313	--	6.5%	23%	--	MAX CCW

Determine first which resolver numbers are concerned and then select the correct trim procedure.

#### Trimming Procedures for Resolvers Paralleled in Groups of Two

The diagram of figure 86 shows the method of paralleling two resolvers on the output of one amplifier (BuOrd Dwg 1371930, Unit 3012). Notice that one resolver provides the feedback to the summing network. This resolver is called the feedback resolver. The second resolver, which is connected in parallel with the feedback resolver, is called the shunt resolver.

The general procedure for trimming resolvers paralleled in groups of two is the same for all loops, and may be summarized as follows: Remove the network boxes loading down the resolver outputs (except for ZN4304). Connect a 1:1 network box (BuOrd Dwg 952085-1) between the feedback resolver output and the signal source, as shown in figure 86. Disconnect the original trim and connect the two decade boxes to the terminal block as shown in figures 87 and 88. The resolver being trimmed is made to put out a -1-volt signal by placing the special test probe of the test unit on the remaining resolver winding and then by turning the resolver rotor until the test unit reads exactly zero. As the resolver is being turned, the null from the 1:1 network box as read on the VTVM should decrease. If the reading increases, the resolver is being turned in the wrong direction, that is, toward plus 90 degrees. Follow the procedure just given with the shunt resolver. If the angle of rotation of the resolver is limited, open the gear mesh.

As shown in figure 86, several different sets of trims are used with each pair of resolvers. Capacitors that are marked "C" in figure 86 are placed on the outputs of both resolvers and on the feedback windings. These capacitors are for trimming

the lead capacitance only and should not be disturbed. The other trim components are marked Cs, Rs, Cf, and Rt. These last four components always must be rechecked or reset whenever a resolver of a pair is changed.

The decade boxes needed for trimming these resolvers, as well as their electrical connections, are shown in figures 87 and 88. Notice that the 100-ohm resistor shown in figure 87 is a special temperature compensated resistor. If decade resistance boxes of the required ranges are not available, use potentiometers connected between the same terminals instead. If no decade capacitance box is available, use fixed capacitors one by one until the correct trim is obtained.

Use the following initial settings for trimming:

Rf equals 2000 ohms      Rs equals 40 ohms  
Cf equals 0.002 mfd      Cs equals 0.4 mfd

Trim Rf and Cf first by observing the null from the network box connected to the output of the feedback resolver. Vary the decades Rf and Cf until a minimum value is read on the VTVM. Now connect the 1:1 box between the output of the shunt resolver and the signal source. Without changing Rf or Cf, vary Rs and Cs until the best null is obtained. Connect the 1:1 box to the output of the feedback resolver again. If the null has changed, readjust Rf and Cf until the best null is obtained again. Proceed back and forth between the resolvers until it is found that a null has not changed. Usually two or three cycles will be sufficient to obtain optimum nulls.

Finally, substitute fixed components for the decades, and recheck the nulls. If the null changes by more than 300 microvolts, select other components that will bring the reading in closer. There is sufficient space on each terminal board for two series resistors and two parallel capacitors.

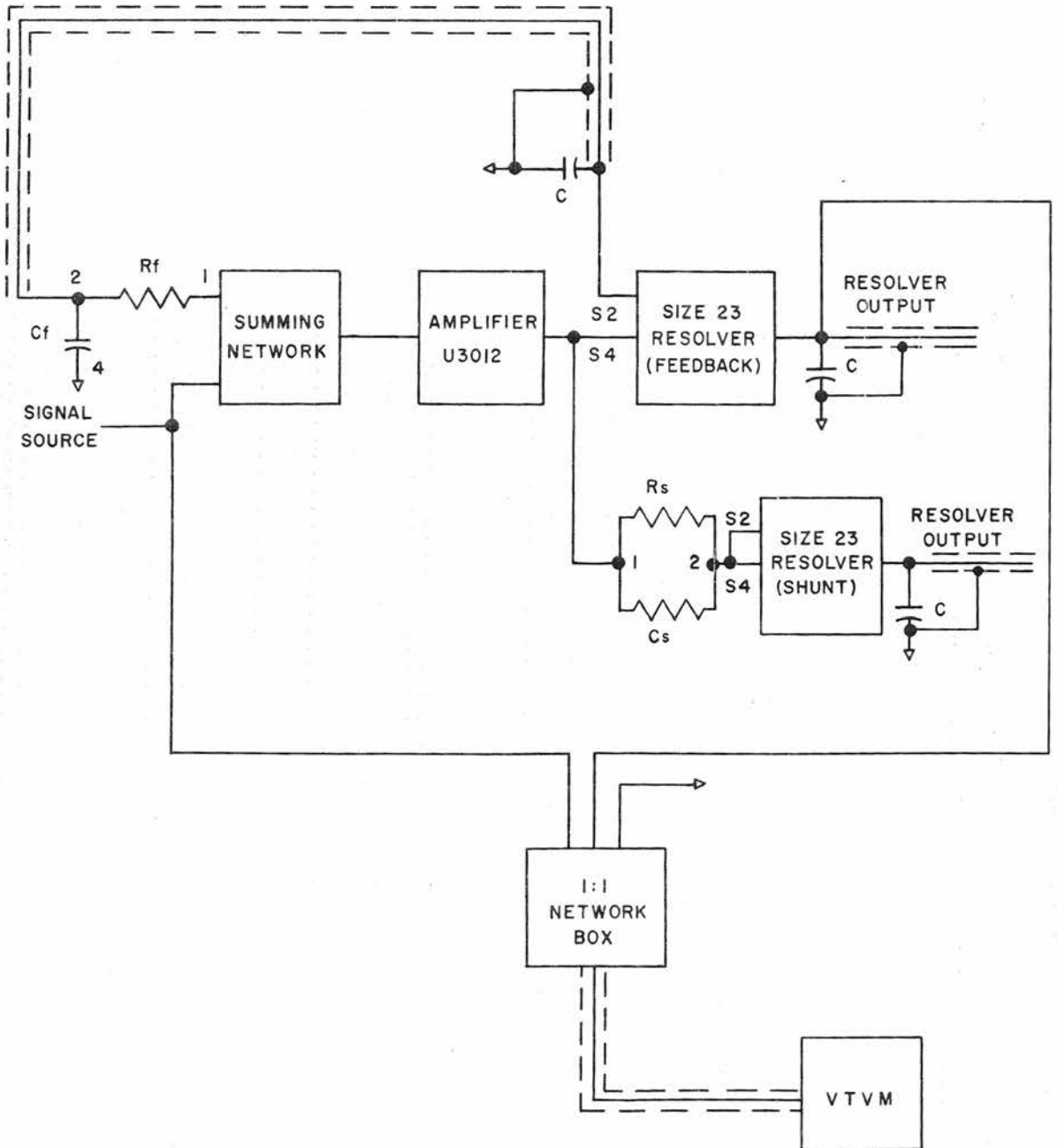

Figure 86. Schematic of Null Measuring System for Resolver Trimming

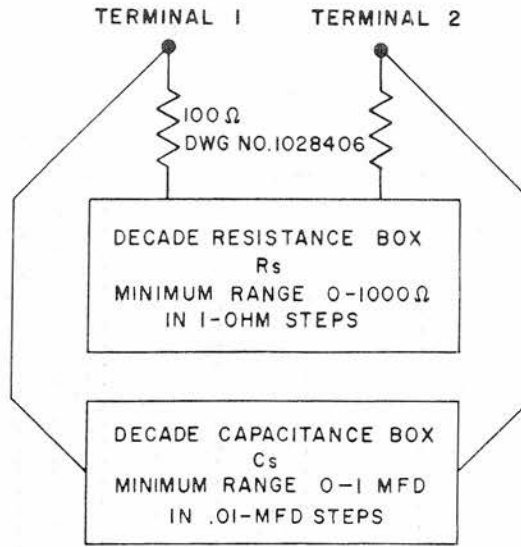
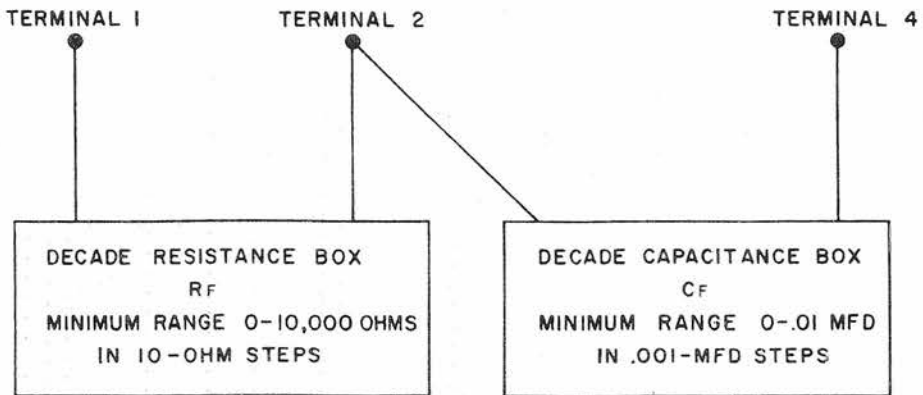

Figure 87. Method of Connecting  $R_s$  and  $C_s$

Figure 88. Method of Connecting  $R_f$  and  $C_f$

## Specific Trim Procedures

## A. Trim of Resolvers on Output of Amplifier ZA4331 B (Resolvers B4096 and B4099)

1. Feedback resolver is B4096. Shunt resolver is B4099.
2. Remove network box ZN4141. Do not remove network box ZN4304.
3. Connect Rf and Cf to terminal block E4336. Connect Rs and Cs to terminal block E4065.
4. Connect the 1:1 box between terminals E4022-11 and B4096-R4. Connect the special test probe on R1 of resolver B4096. Set test switch at 7E and turn the resolver to +90 degrees.
5. Vary Rf and Cf until a best null is obtained on the VTVM.
6. Disconnect the 1:1 box from B4096-R4 and connect it to E4031-3. Connect the special test probe to R1 on B4099. Turn the rotor of B4099 to +90 degrees.
7. Vary Rs and Cs until the best null is read.
8. Reconnect the 1:1 box to B4096-R4. If necessary, readjust Rf and Cf. Continue this way until both nulls are optimum.
9. Connect a 1/2 watt, 5 per cent carbon resistor, of the nearest value below Rf between terminals E4336-1 and E4336-3, and connect the Rf decade between E4336-3 and E4336-2. Connect a fixed value mica capacitor of the nearest value below Cf between E4336-2 and E4336-4. Leave the Cf decade connected between these two terminals. In one of the spaces avail-

able on E4065, place a 1 per cent wirewound 100-ohm temperature compensated resistor (Dwg 1028406) in series with a regular 1 per cent wirewound resistor. The value of the latter resistor will be the difference between the Rs decade reading and 100 ohms. Next, connect the Rs decade in series with the two resistors first mentioned. Place a tubular paper capacitor, 100-watt VDC of the nearest value below Cs (maximum value 0.47 mfd), between terminals E4065-1 and E4065-2. Reset the decades so that the original nulls are again obtained. The decade settings show the amount of additional resistance and capacitance required for each trim. Insert the additional fixed trims, and check the nulls. For these resolvers, a change in null of 500 microvolts is acceptable.

## B. Trim of Resolver on Output of amplifier ZA4331 A (Resolvers B4085 and B4092)

1. Feedback resolver is B4085. Shunt resolver is B4092.
2. Remove network boxes ZN4327 and ZN4310.
3. Remove amplifier ZA 4333 and jump the following terminals on B4092 to ground: S1 and S3
4. Remove network box ZN4331, and replace with network box ZN4333 (BuOrd dwg 952085-44).
5. Hand servo B4083 to the limit stop.
6. Connect Rf and Cf to terminal board E4335. Connect Rs and Cs to terminal board E4064.

7. Connect the 1:1 box between B4083-R2 and E4051-6. Set the special test probe on R1 of B4085 and computer test selector switch at 7E and proceed as in steps A4 and A5.
  8. Disconnect the 1:1 box from terminal board E4051-6 and connect it to E4033-5. Set the computer test selector switch on 7B and proceed as in steps A6 and A7.
  9. Complete trimmings as described in steps A8 and A9.
- C. Trim of Resolvers on Output of Amplifier ZA4329A (Resolvers B4093 and B4088).
1. Feedback resolver is B4093. Shunt resolver is B4088.
  2. Remove network boxes ZN4314 and ZN4315.
  3. Put MODE SELECTOR switch in MB position.
  4. Disconnect terminal B4083-R1 and jump it to ground.
  5. Set TEST SELECTOR switch on 5C. Hand servo B4084 until the test unit reads approximately +6 volts.
  6. Connect Rf to Cf to terminal board E4333 and Rs and Cs to E4062.
  7. Connect the special test probe to R1 or B4093. Set the test selector switch at 7E. Connect the 1:1 box between terminal boards E4306-11 and E4033-12, and proceed as in steps A4 and A5.
  8. Disconnect the 1:1 box from terminal board E4033-12, and connect to terminal E4034-2. Connect special test probe to terminal R1 or B4088. Proceed as in steps A6 and A7.
9. Complete trimming as described in steps A8 and A9.
- D. Trim of Resolvers on Output of Amplifier ZA4329-B (Resolvers B4086 and B4090)
1. Feedback resolver is B4086. Shunt resolver is B4090.
  2. Remove network boxes ZN4314 and ZN4315.
  3. Remove network box ZN4330 and replace by network box ZN4329 (BuOrd dwg 951731-87).
  4. Disconnect terminal B4083-R1 and jump it to ground.
  5. Set the TEST SELECTOR switch on 5D. Hand servo B4084 until the test unit reads -6 volts.
  6. Connect Rf and Cf to E4334 and Rs and Cs to E4063.
  7. Connect 1:1 box between E4306-4 and E4034-3. Connect the special test probe to R3 of B4086. Set TEST SELECTOR switch to 7E position. Proceed as in steps A4 and A5.
  8. Disconnect the 1:1 box from terminal E4034-3, and connect to terminal E4033-8. Connect the special test probe to R3 or B4090. Proceed as in steps A6 and A7.
  9. Complete trimming as described in steps A8 and A9.

#### Trimming Procedures for Resolvers Paralleled in Groups of Four

Resolvers paralleled in groups of four must be trimmed to keep the capacitance-to-ground effects for certain cables at a specific value. The procedures that follow

are used to duplicate the original specified capacitance-to-ground values and differ from those used in trimming resolvers paralleled in groups of two in that most of the steps consist of only resistance and capacitance measurements. Take the measurements in the step-by-step method listed for the particular resolver and select fixed components to duplicate the required trim. The resolvers that are covered in each of the two procedures are given in the main title of the procedure.

#### Specific Trim Procedures:

##### E. Trim of Resolvers on Output of Amplifier ZA4325 (Resolvers B4098, B4097, B4083, and B4084).

1. Measure the capacitance to ground of the following cables. In each measurement, the cable must be disconnected at both ends.

- a. From terminal E of network box ZN4325.
- b. From terminal S2 of resolver B4083.
- c. From terminal S4 of resolver B4098.
- d. From terminal R4 of resolver B4097.
- e. From terminal R1 and from terminal "R2" of resolver B4083.
- f. From terminal R1 and from terminal "R3" of resolver B4084.
- g. From terminal R2 of resolver B4084.

2. For the cable measured in step E. a., add capacitance such that the sum of the measured and

added capacitance is 1000 mmf  $\pm 2.5$  per cent.

3. For each cable measured in steps E. b., E. c., E. d., E. e. and E. g., add capacitance so that the sum of the measured and added capacitance is 2000 mmf  $\pm 5$  per cent.

4. For each cable measured in step E. f., add capacitance such that the sum of the measured and added capacitance is 4000 mmf  $\pm 5$  per cent.

5. Insert 2000 mmf to ground at each of the following points:

- a. R1 of resolver B4098.
- b. R1 of resolver B4097.

##### F. Trim of Resolvers on Output of Amplifier ZA4327 (Resolver B4087, B4091, B4089, and B4094).

1. Measure the capacitance to ground of the following cables. In each measurement, the cable must be disconnected at both ends.

- a. From terminal E of network box ZN4327.
- b. From terminal S2 of resolver B4091.
- c. From terminal R3 of resolver B4087.
- d. From terminal R1 and from terminal R3 of resolver B4089.
- e. From terminal R3 of resolver B4094.
- f. From terminal R1 of resolver B4091.

2. For the cable measured in step F. a., add capacitance such that the

sum of the measured and added capacitance is 1000 mmf  $\pm 2.5$  per cent.

3. For each cable measured in steps F. b. , F. c. , F. e. and F. f. , add capacitance such that the sum of the measured and added capacitance is 2000 mmf  $\pm 5$  per cent.
4. For each cable measured in step E. d. , add capacitance such that the sum of the measured and added

capacitance is 4000 mmf  $\pm 5$  per cent

5. Insert 2000 mmf to ground at each of the following points:
  - a. R4 of resolver B4087.
  - b. R2 of resolver B4091.
  - c. R2 of resolver B4089.
  - d. R2 of resolver B4094.

### Section 5.5—Adjustment, Assembly, and Disassembly

This section consists of the complete adjustment procedure with illustrations that show the location of adjustment points, and reference information on assembly and disassembly. Diagrams showing the mechanisms and adjustments schematically (figure 47 through 59) are included in section 5.3. For adjustment of servo control potentiometers, refer to section 5.4.

#### ADJUSTMENT PROCEDURE

The complete adjustment procedure is given in table 70. The adjustments are tabulated in groups according to function and in logical order. This order should be followed whenever the entire instrument or any portion of it is being adjusted. The "A" numbers in the first column of the table serve to identify the adjustment and do not necessarily indicate its order in the procedure. In cases where the adjustment takes the form of a clamp securing a gear or coupling to a shaft, the identifying "A" number appears on the clamp. However, in the case of certain dials, synchros, and resolvers, the adjustments, which are made by loosening the securing screws or nuts, have no identification indicated in the instrument. Adjustment points for

which the procedure consists of the word "tighten" are included to facilitate assembly of the instrument and thus are classified as assembly clamps.

Where the procedure is used for readjustment of a single adjustment point or a small number of points, study the pertinent functional schematic to determine all other points that could be affected by the readjustment. Then, check these points in accordance with the corresponding procedures in table 70.

#### Checking an Adjustment

The procedure given in the last column of table 70 serves as an individual performance test for any adjustment. If the results of trouble analysis, as described in section 5.3, indicate that an adjustment may be inaccurate, perform the procedure for that adjustment before actually disturbing it to prove whether readjustment should be attempted. During any readjustment procedure, inability to fulfill the adjustment performance requirements given in the table and any other abnormal indications should be investigated. Refer to Common Mechanical and Electrical Faults, section 5.3.

### Adjustment Practice

A critical adjustment of a clamp can be accomplished more easily if the clamp is slip-tightened or partially tightened so that the adjustment can be slipped with light pressure, yet will remain sufficiently tight to prevent unwanted movement of the part during a check. Then, after the clamp adjustment is found to be correct, a slight additional turn of the clamp screw will lock the clamp without disturbing the adjustment.

Frequently, gearing which is not directly accessible to the hand must be repositioned to perform an adjustment. This may be done by gently pushing the line with a soft metal gear-pusher. Never use a screwdriver. With certain adjustments the gearing must be wedged tightly to complete the adjustment. Wedges made from linen bakelite are recommended. Wooden wedges are not recommended because

fallen chips of wood could interfere with the proper operation of a mechanism. All wedges used in these adjustments should be inserted by hand between a side of a gear and a fixed hanger or plate. They should never be hammered into place. Never wedge counters or differentials because these two mechanisms are both susceptible to damage from this type of treatment.

### ASSEMBLY AND DISASSEMBLY

The pictures used to illustrate component and adjustment locations, figures 89 through 96, can be used as a general guide in maintenance operations involving assembly and disassembly of Computer Mk 48 Mod 1. If the operation to be performed requires more complete information, than a complete set of assembly drawings should be available before proceeding. Appendix A lists the BuOrd numbers of these drawings.

Table 70

### ADJUSTMENT PROCEDURE

The test unit, unit 4400, BuOrd dwg 1371829, is used to check and adjust Computer Mk 48 Mod 1, and must be adjusted prior to any adjusting of the computer proper. The test unit is energized from the computer through power cable 888783.

With Computer Mk 48 Mod 1 energized, and the test-unit TEST SELECTOR switch at OFF, proceed as follows:

Adj No	Function	Connection	Procedure
A1		Assembly	Tighten
A2		Assembly	Tighten
None		Coarse to fine dial	Set zero of coarse and fine dials together at index.

Table 70 (Cont'd)

## ADJUSTMENT PROCEDURE

Adj No	Function	Connection	Procedure
A4	Test	Dials to stop H44L1	See limit at $\pm 12.05$ on dials.
None		Lost motion take-up spring	Wind up spring to remove backlash in gearing.
A3		Dials to pot R4401	<p>With dials at zero, set pot to mid-point of mechanical travel. Then, with the test-unit TEST SELECTOR switch at OFF and test unit energized, refine setting so that dials read 0.000.</p> <p>With switch at +12 position, dial should read +12.00. With switch at -12 position, dial should read -12.00.</p>

The following assembly clamps must be tightened before proceeding with adjustments of Computer Mk 48 Mod 1.

Assembly Clamp	Fig No	Location
A1	93	Pinions on servo motor shafts B100, B101, B4002, B4003, B4004, B4005, B4006, B4007, B4008, B4009, B4010, B4011, B4012, B4013, B4014, B4015, and B4016.
A2	93	Pinions on induction generator shafts G100, G101, G4002, G4003, G4004, G4005, G4006, G4007, G4008, G4009, G4010, G4011, G4012, G4013, G4014, G4015, and G4016.
A3	89	Spur gears on 1/50 hp motor B4017.

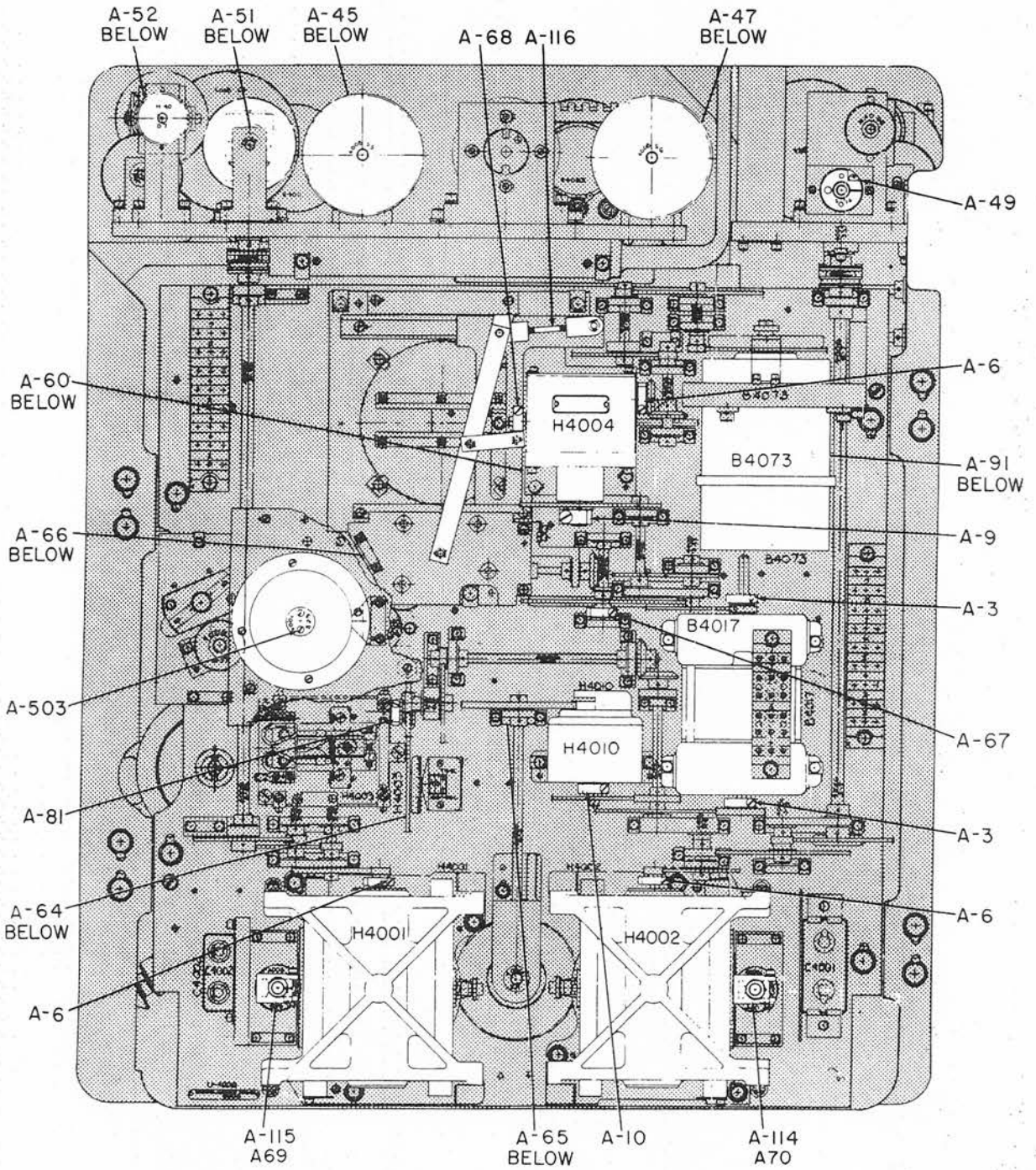

Figure 89. Front Mechanical Section Under Cover No. 5

Table 70 (Cont'd)

## ADJUSTMENT PROCEDURE

Assembly Clamp	Fig No	Location		
A5	93	Spur gears on pot shafts R100, R101, R4001, R4002, R4003, R4004, R4005, R4006, R4007, R4008, R4010, R4011, R4014, R4018, R4020, and R4022.		
A6	89	Bevel or spur gears on integrator roller shafts H4001, H4002, and H4004.		
A7	95	Bevel gears on counter shafts So, Es, Hs, and Ht. Spur gears on counter shafts SF, Hs, Ht, and Time.		
A9	89	Spur gear on integrator disk shaft H4004.		
A10	89	Spur gear on clutch shaft H4010.		

Adj No	Fig No	Function	Connection	Procedure
None	--	Co	1HCT B4052 to shafts 1302S2 and 1302S3	Remove synchro from mesh with shafts 1302S2 and 1302S3. Wind take-up spring sufficiently to remove lost motion. Replace synchro.
A63	91	Co	Fine 1HCT B4052 to coarse 1HCT B4053	Set fine and coarse synchros together on electrical zero.
A64	89	Co	Co dials to 1HCTs B4052 and B4053	With Co receivers on electrical zero, set fine and coarse dials on zero.
*A503	89	Co	Fine and coarse dials	
A65	89	Co	Receiver to component solver U0620	With Co receiver on electrical zero, set vector gear to produce no movement of dXo rack.
A55	95	So	So counter to stop H40L18	Set stop to read zero and 55 knots on counter.

\* Number not indicated in instrument.

Table 70 (Cont'd)

## ADJUSTMENT PROCEDURE

Adj No	Fig No	Function	Connection	Procedure
A57	94	So	So receiver (B4070) to counter	With So receiver at electrical zero, set So counter to read zero.
A58	90	So	So receiver (B4070) to component solver U0620	With So receiver and counter on zero, set speed cam to produce no movement of dXo and dYo racks for 360° rotation of vector gear.
A81	89	Time	Regulator H4003 to time motor B4017	Adjust friction to drive regulator mechanism in normal direction. Check that friction slips if time line is turned backwards.
A69 A115	89	dYo	Integrator carriage H4001 to component solver U0620	With time motor running and So on zero, set integrator carriage to produce no movement of roller, Yo.
A70 A114	89	dXo	Integrator carriage H4002 to component solver U0620.	With time motor running and So on zero, set integrator carriage to produce no movement of roller, Xo.
A49 A50	89 95	Xo Xa	Holding friction	Set friction to hold Xo and Xa inputs to H40D8. With Xa handle disengaged, Xo signal should not back out through A50. With Xa handle engaged, Xa signal should not back out A49.
A47	95	Xt	Holding friction	Set friction to hold Xt setting.

CONFIDENTIAL

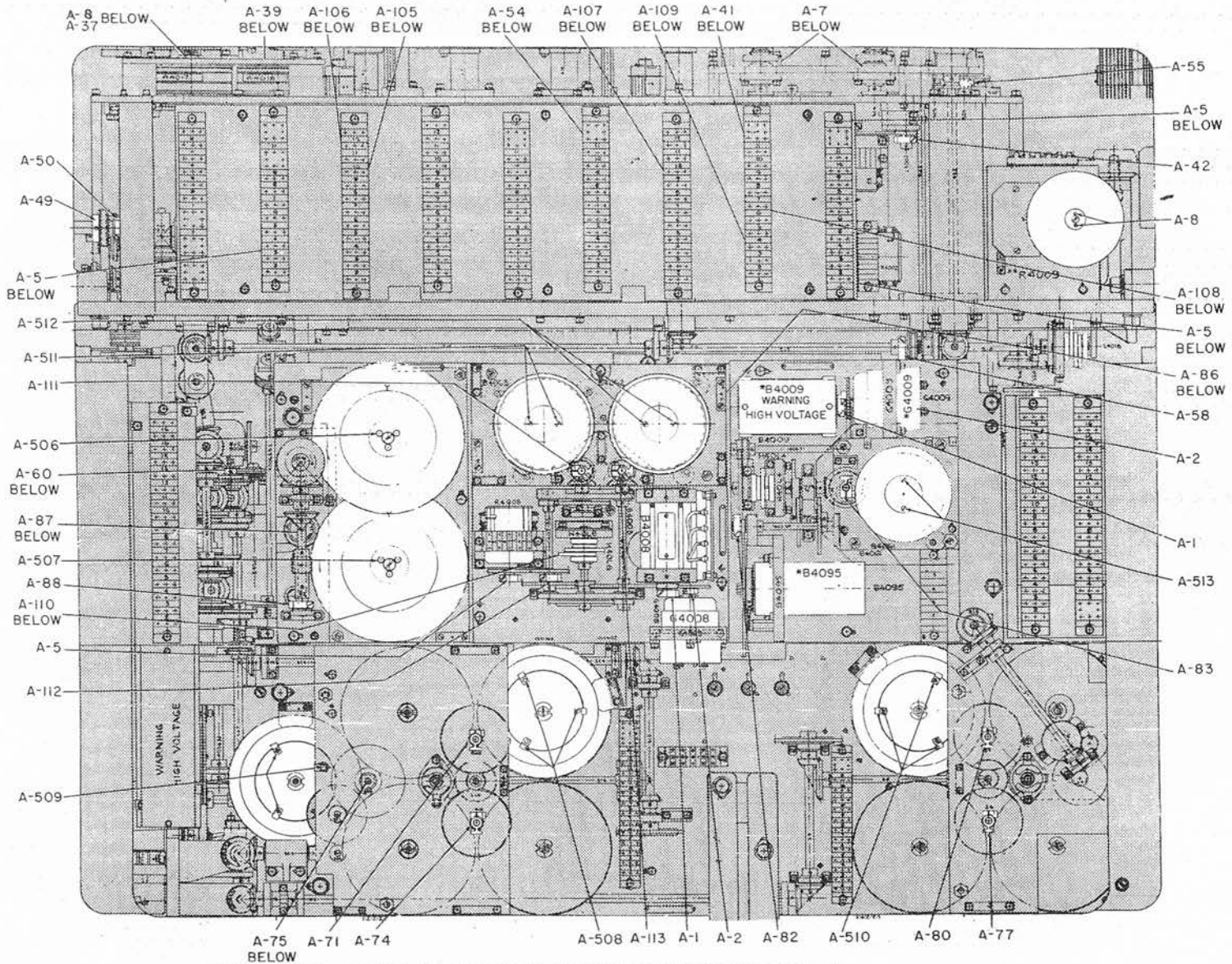

Figure 90. Right Mechanical Section Under Cover No. 6

CONFIDENTIAL

Table 70 (Cont'd)

## ADJUSTMENT PROCEDURE

Adj No	Fig No	Function	Connection	Procedure
A51	89	Yo	Holding friction	Set friction to hold Yo and Ya inputs to H40D7. With Ya handle disengaged, Yo signals should not back out A52. With Ya handle engaged, Ya signal should not back out A51.
A52	95	Ya		
A45	95	Yt	Holding friction	Set friction to hold Yt setting.
A46	95	Yt	R4004 to R4013	With both R4004 and R4013 sliptight, rotate Yt handle clockwise until both pots hit their stops. Tighten clamps. Check with mode-and-plot switch (S4006) at SHORE BOMB TGT and TSS(SIGNAL TEST SELECTOR switches) at 3D for R4004, and 3E for R4013, so that R4013 reads 0 when R4004 reads 0.
A48	95	Xt	R4003 to R4012	With both R4003 and R4012 sliptight, rotate Xt handle clockwise until both pots hit their stops. Tighten clamps. Check with mode-and-plot switch (S4006) at SHORE BOMB TGT and TSS at 2G for R4003, and 3A for R4012, so that R4012 reads 0 when R4003 reads 0.
None	--	Xa	Pot R4010 and Xa handcrank	With mode-and-plot switch (S4006) at SHORE BOMB SHIP and TSS at either 2F or 2G, extreme CW rotation of Xa handle will produce reading of +12 v CCW rotation, reading = -12 v.

Table 70 (Cont'd)  
ADJUSTMENT PROCEDURE

Adj No	Fig No	Function	Connection	Procedure						
None	--	Ya	Pot R4011 and Ya handcrank	With mode-and-pot switch (S4006) at SHORE BOMB SHIP and TSS at either 3D or 3C, extreme CW rotation of Ya handle will produce reading of +12 v. CCW rotation, reading = -12 v.						
*A501	95	Yj	Yj dial to limit stop H40L9	See limit stop to act a $\pm 1017.5$ on dials. At same time set the detent to operate at 25-yd intervals on dial.						
A8	90	Yj	Yj dial to detent on shaft 4004S29							
A37	90	Yj	Pot R4017 to Yj dial	With $\pm 12$ v across pot, pot outputs to read as follows: <table style="margin-left: auto; margin-right: auto;"> <tr> <td style="text-align: left;">Dial Reading</td> <td style="text-align: left;">TSS at 3B</td> </tr> <tr> <td>+1000 yds</td> <td>-10.97 volts</td> </tr> <tr> <td>-1000 yds</td> <td>+10.97 volts</td> </tr> </table>	Dial Reading	TSS at 3B	+1000 yds	-10.97 volts	-1000 yds	+10.97 volts
Dial Reading	TSS at 3B									
+1000 yds	-10.97 volts									
-1000 yds	+10.97 volts									
*A502	95	Xj	Xj dial to limit stop H40L3	Set limit stop to act at $\pm 1017.5$ on dials. At the same time, set the detent to operate at 25-yd intervals on dial.						
A8	90	Xj	Xj dial to detent on shaft 4004S32							
A39	90	Xj	Pot R4016 to Xj dial	With $\pm 12$ v across pot, pot outputs to read as follows: <table style="margin-left: auto; margin-right: auto;"> <tr> <td style="text-align: left;">Dial Reading</td> <td style="text-align: left;">TSS at 2E</td> </tr> <tr> <td>+1000 yds</td> <td>-10.97 volts</td> </tr> <tr> <td>-1000 yds</td> <td>+10.97 volts</td> </tr> </table>	Dial Reading	TSS at 2E	+1000 yds	-10.97 volts	-1000 yds	+10.97 volts
Dial Reading	TSS at 2E									
+1000 yds	-10.97 volts									
-1000 yds	+10.97 volts									
A7	90	Ht	Ht(feet) counter stop H40L6	Set stop limits to 0 and 5000 feet on counter.						
A7	90	Ht	Ht(feet) counter to Ht(meter) counter	Ht(meter) counter to read 0 meters for 0 feet on Ht(feet) counter, and 1524 meters at 5000 feet.						

\* Number not indicated in instrument

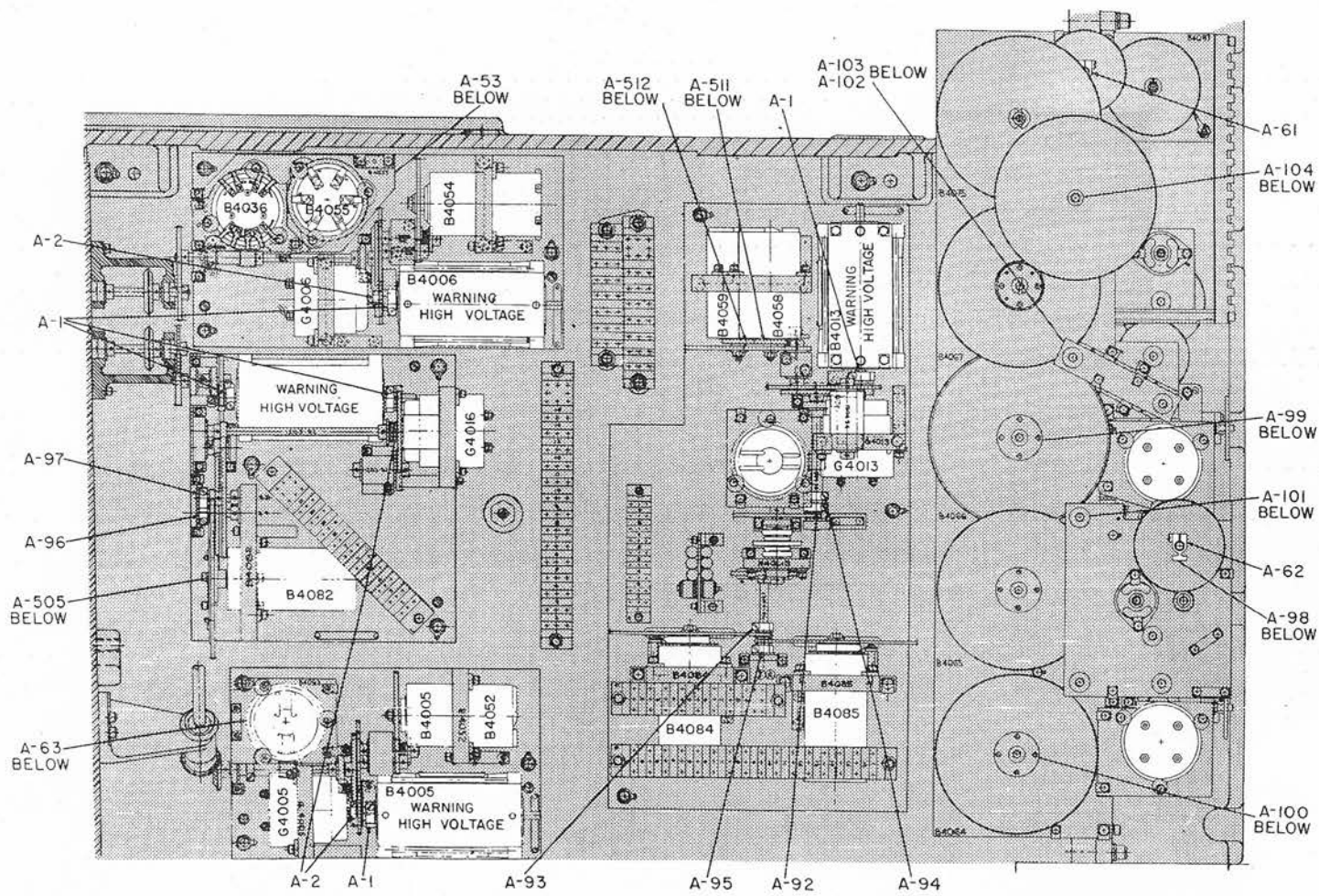

Figure 91. Mechanical Section Left Wall as Viewed from Right Side

Table 70 (Cont'd)

## ADJUSTMENT PROCEDURE

Adj No	Fig No	Function	Connection	Procedure
A41	90	Ht	R4006 to stop and counter	With +12 v across pot and TSS at 4A, dials at 0, and stop at lower limit (extreme CCW rotation of Ht handle), test reading = 0. Turn Ht handle CW to dial reading of 3000 feet. Test reading 7.074 v.
A7	95	Hs	Hs(feet) counter to stop H40L5	Set stop limits to 0 and 5000 feet on counter.
A7	95	Hs	Hs(feet) counter to Hs(meter) counter	Hs(meter) counter to read 0 for 0 feet on Hs(feet) counter, and 1524 meters at 5000 feet.
A42	90	Hs	R4005 to stop and counter	With +12 v across pot and TSS at 1D, dials at 0 and stop at lower limit (extreme CCW rotation of Hs handle), test reading = 0. Turn Hs handle CW to dial reading of 3000 feet. Test reading = 7.074 v.
A35	95	SF	Holding friction	Set friction to hold scale factor setting.
A7	90	SF	Stop H40L20 to counter	With clamp A7 loose, depress SF push button and rotate SF handcrank CW to upper limit of stop. Set counter to read 100,000:1, and tighten A7. Rotate SF CCW to lower limit of stop, check reading of 10,000:1 on counter.

Table 70 (Cont'd)  
ADJUSTMENT PROCEDURE

Adj No	Fig No	Function	Connection	Procedure								
A34	95	SF	Pot R4001 to stop H40L20 and counter	With +12 v across pot, TSS at 4G, and counter at 100,000:1, set pot to test reading of 12,000 v; rotate SF handcrank CCW to counter reading of 10,000:1. Check test reading of 1.200 v.								
A36	94	SF	Pots R4019 and R4020 to counter	With SF counter at 100,000:1, resistance between slider and terminal 2 of pots should be at a minimum. Check to see that resistance increases as SF decreases.								
A12	93	Xp (E-W)	Counter to stop	Set stop to act from 32.8 (lower) to 0 (upper limit) on counter.								
A15	93	Xp (N-S)	Counter to stop H40L2	Set stop to read from 0 to 32.8 on counter.								
A11	93	Xp (E-W)	Plotter to Xp counter and stop H40L1	Run plotter light to end of screws at lower right-hand corner. Back off one turn on each screw. Counter should be at zero. H40L2 at lower limit; H40L1 at upper limit. Check that at upper left-hand corner stops act at 32.8, and before end of each lead screw.								
A14	93	Xp (E-W)	Plotter to Xp counter and stop H40L2									
A13	93	Xp	Pot R100 to counter	With SF counter at 100,000:1, TSS at 4E for R100 and for R101, set as follows:								
A16	93	Xp	Pot R101 to counter	<table style="margin-left: auto; margin-right: auto;"> <tr> <td><math>\frac{Yp}{0}</math></td> <td><math>\frac{Xp}{32.8}</math></td> <td><math>\frac{4E}{.30}</math></td> <td><math>\frac{4F}{30}</math></td> </tr> <tr> <td>32.8</td> <td>0</td> <td>11.39 v</td> <td>11.39 v</td> </tr> </table>	$\frac{Yp}{0}$	$\frac{Xp}{32.8}$	$\frac{4E}{.30}$	$\frac{4F}{30}$	32.8	0	11.39 v	11.39 v
$\frac{Yp}{0}$	$\frac{Xp}{32.8}$	$\frac{4E}{.30}$	$\frac{4F}{30}$									
32.8	0	11.39 v	11.39 v									

Table 70 (Cont'd)  
ADJUSTMENT PROCEDURE

Adj No	Fig No	Function	Connection	Procedure
None		R	1HCT B4050 to shafts 4004S4 and 4004S5	Remove synchro from mesh with shafts 4004S4 and 4004S5. Wind take-up spring sufficiently to remove lost motion. Replace synchro.
A107	90	R	Fine 1HCT B4050 to coarse 1HCT B4051	Set fine and coarse synchros together on electrical zero.
A105	90	R	R dials to 1HCTs B4050 and B4051	With R receivers on electrical zero, set range dials to read 10,000 yds.
*A504	95	R	Fine and coarse dials	
A106	90	R	Receiver to stop H40L19	Set stop to act at 500 yds, and 50,000 yds on dial.
A108	90	R	Pot R4002 to receiver, stop, and dial	With TSS at 1A and receiver at 10,000 yds, set pot to test reading of +2.350, increasing. Check test reading: R = 50,000, Reading = +11.750 R = 1000, Reading = +0.235
A109	90	R	Pot R4014 to R dials	With R = 50,000 yds, resistance between slider and terminal 1 of pot should be at a minimum. Check to see that resistance increases as R decreases.
A86	92	Es	Counter to stop H40L7	Set stop to act at 2000 min and 3800 min.

\* Number not indicated in instrument.

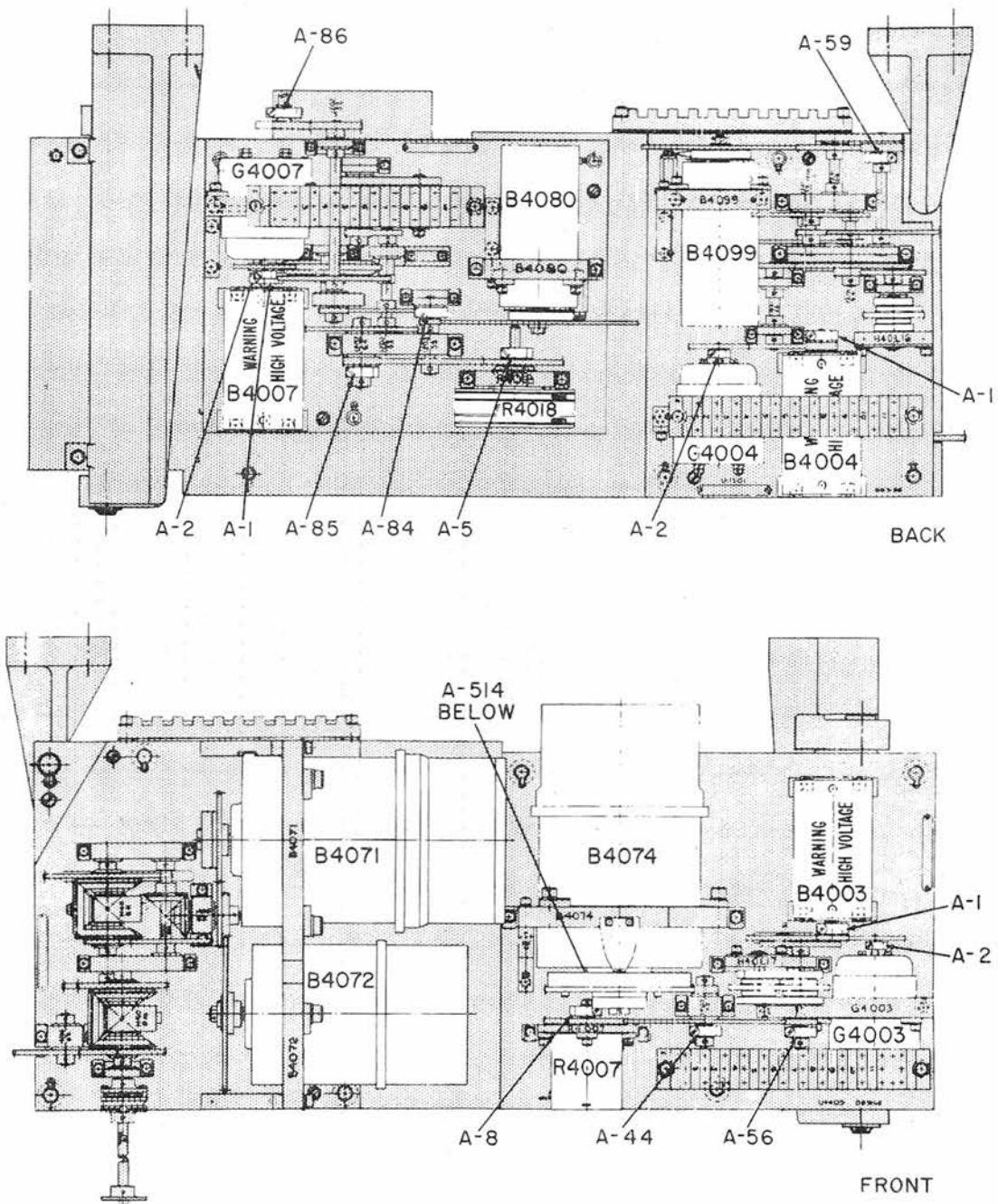

Figure 92. Front and Back Sides of Hinged Plate

Table 70 (Cont'd)

## ADJUSTMENT PROCEDURE

Adj No	Fig No	Function	Connection	Procedure
A84	92	Es	Resolver B4080 to stop H40L7	With A84 loose and A85 tight, turn shaft 1202S5 CW (viewed from A84 end) until limit stop hits. Turn gear on resolver shaft until take-up spring is wound solid. Back off 1/2 turn and tighten clamp A84.
**A85	92	Es	Resolver B4080 to counter	With Es on 2000 min, TSS at 1B position, turn resolver shaft CW (viewed from gear end) to give a test reading of zero for output, decreasing from plus to minus, with TSS at 1C. Es = 2000 min, R = 50,000 yds. Test reading = +11.750. With R = 30,000 yds, Es = 3800 min. Test readings at 1B = -3.525, 1C = 6.105. Check that take-up spring is active throughout resolver travel. Refine with A84 if necessary.
None	--	Rj	Pot R4009 to Rj dial	With Rj switch on; Hs, Ht, OL', OZh, Xa, Ya, Xt and Yt = 0; R = 20,000 yds; set Rj pot R4009 such that OR dial = 19,900 when Rj dial = 100.
None	--	B'r'	1HCT B4054 to shafts 1305S2 and 1305S3	Remove synchro from mesh with shafts 1305S2 and 1305S3. Wind take-up spring sufficiently to remove lost motion. Replace synchro.

\*\* Set A5, page 284 at this point.

Table 70 (Cont'd)

## ADJUSTMENT PROCEDURE

Adj No	Fig No	Function	Connection	Procedure
A90	96	OL'	Resolver B4083 to stop H40L12	Turn shaft 1301S5 CCW (viewed from clamp end) until stop hits. Turn gear on resolver shaft CCW (viewed from gear end) until take-up spring is wound solid. Back off 1/2 turn and tighten A90.
None	--	OL'	Resolver B4083 to OL' receivers	With OL' receivers on electrical zero, TSS at 5B position, rotate resolver rotor CW to a test reading of zero, increasing. With TSS at 5A, check test reading of +12.000 v. Check that take-up spring is active throughout resolver travel. Refine setting with A90, if necessary.
*A512	91	OZh	Fine 1HCT B4059 to shaft 1304S2	Remove 1HCT from mesh with shaft 1304S2. Wind take-up spring sufficiently to remove lost motion. Replace synchro.
A94	91	OZh	Fine 1HCT B4059 to coarse 1HCT B4060	Set fine and coarse synchros together on electrical zero.
*A511	91	OZh	Fine 1HCT B4058 to coarse 1HCT B4060	With switch S4002 on AA position, B4060 on electrical zero as in A94, set B4058 on electrical zero. Turn switch to MB position, and check that B4059 is on electrical zero.

\*Number not indicated in instrument.

Table 70 (Cont'd)

## ADJUSTMENT PROCEDURE

Adj No	Fig No	Function	Connection	Procedure
None	91	B'r'	Fine 1HCT B4054 to coarse 1HCT B4055	Set fine and coarse synchros together at electrical zero.
A53	91	B'r'	Resolver B4096 to shaft 1305S4	With B'r' at 0°, TSS at 1E position, rotate resolver shaft CW to a test reading of zero, decreasing.
*A500	95	B'r'	Fine and coarse dials	Set fine and coarse dials together on zero.
A54	90	B'r'	Receivers to fine and coarse dials	With B'r' receivers on electrical zero, set dials on zero.
None	--	OL'	1HCT B4056 to shafts 1301S2 and 1301S3	Remove 1HCT from mesh with shafts 1301S2 and 1301S3. Wind take-up spring sufficiently to remove lost motion. Replace synchro.
A89	96	OL'	Fine 1HCT B4056 to coarse 1HCT B4057	Set fine and coarse synchros together on electrical zero.
A117	96	OL'	Receiver to stop H40L12	With receiver at electrical zero, set stop at midpoint of travel. When stop is set correctly, shafts 1301S2 and 1301S3 will turn exactly 10 turns in each direction from position where synchros are at electrical zero.

\* Number not indicated in instrument.



Table 70 (Cont'd)

## ADJUSTMENT PROCEDURE

Adj No	Fig No	Function	Connection	Procedure
A92	91	OZh	Receivers to stop H40L13	With receivers on electrical zero, set stop H40L13 at mid-point of its travel. When stop is set correctly, shafts 1304S2 and S3 will turn exactly 10 turns in each direction from position where synchros are at electrical zero.
A93	91	OZh	Resolver B4084 to stop H40L13	Turn shaft 1304S6 CW (viewed from clamp end) until limit stop hits. Rotate gear on each resolver CW (viewed from gear end) until take-up spring is wound solid. Back off 1/2 turn, and tighten clamps.
A95	91	OZh	Resolver B4085 to stop H40L13	
None	--	OZh	Resolver B4084 to receivers	With OZh on electrical zero, TSS at 5E position, rotate resolver CW to a test reading of zero, increasing. Tighten nut, and check at following TSS points: 5C reading = +6.000v 5D reading = -6.000v Check that take-up spring is active throughout resolver travel. Refine settings with A93, if necessary.
None	--	OZh	Resolver B4085 to receiver	With OL' on +20°, OZh on electrical zero, TSS at 6C position, rotate resolver rotor CW to a test reading of zero, increasing. With OZh and OL' on +20°, TSS at 6C, check reading of +2.807. Check that take-up spring is active throughout resolver travel. Refine settings with A95, if necessary.

Table 70 (Cont'd)

## ADJUSTMENT PROCEDURE

Adj No	Fig No	Function	Connection	Procedure
A77	96	jOB'r'	Resolver B4089 to limit stop H40L15	With clamps A76, A77, A79, and A80 tight, rotate shaft 4005S6 CCW (viewed from A77 end) until stop H40L15 hits. Wedge stop. Loosen these 4 clamps and rotate resolvers B4086, B4087, B4088, and B4089 rotor gears CCW until springs are wound up solid. Back off 1/2 turn on each spring and tighten 4 clamps. Remove wedge from stop H40L15.
A80	96	jOB'r'	Resolver B4088 to limit stop H40L15	
A76	96	jOB'r'	Resolver B4087 to limit stop	
A79	96	jOB'r'	Resolver B4086 to limit stop H40L15	
A510	96	jOB'r'	Dial to limit stop H40L15	With step H40L15 at its upper limit, rotate shaft 4005S6 CCW (viewed from A77 end) until stop hits, set dial at 20°, tighten screws. Check that stop acts at 340°.
A71	90	jOB'r' -jB'r'	Resolver B4094 to limit stop H40L14	With clamps A71, A72, A73, and A74 tight, rotate shaft 4005S19 CCW (viewed from A71 end) until stop H40L14 hits. Wedge stop. Loosen these 4 clamps, and rotate resolvers B4090, B4091, B4093, and B4094 rotor gears CCW until springs are wound up solid. Back off 1/2 turn on each spring, and tighten 4 clamps. Remove wedge from stop H40L14.
A74	90	jOB'r' -jB'r'	Resolver B4093 to limit stop H40L14	
A72	96	jOB'r' -jB'r'	Resolver B4091 to limit stop H40L14	
A73	96	jOB'r' -jB'r'	Resolver B4090 to limit stop H40L14	

Table 70 (Cont'd)  
ADJUSTMENT PROCEDURE

Adj No	Fig No	Function	Connection	Procedure
A508	90	jOB'r' -jB'r'	Dial to limit stop H40L14	With stop H40L14 at its upper limit, rotate shaft 4005S19 CCW (viewed from A71 end) until stop hits, set dial at 20°, tighten screws. Check that stop acts at 340°.
A91	89	B'r'	jOB'r' and (jOB'r' -jB'r') dials to B'r' receivers B4054 and B4055	Set jOB'r' dial on zero, and wedge line. With B'r' dials on zero, (jOB'r' - jB'r'), dial should read zero.
A59	92	jB	Resolver B4099 to stop H40L16	Turn shaft 1201S1 CCW (viewed from clamp end) until limit stop hits. Turn resolver gear CCW until spring is wound up solid. Back off 1/2 turn, and tighten A59.
None	--	jB	Resolver B4099 to stop H40L16	With stop H40L16 at midpoint of travel, switch S4002 to AA. With TSS at 2A, rotate resolver rotor CW to a reading of zero, decreasing. Refine with A59, if necessary.
None	--	B	Resolver B4081 to stop H40L16	Check that lost motion spring is active throughout limits of stop H40L16. If necessary to adjust, break mesh between 1201S1 and B4081 stator gear, wind up spring, and remesh.

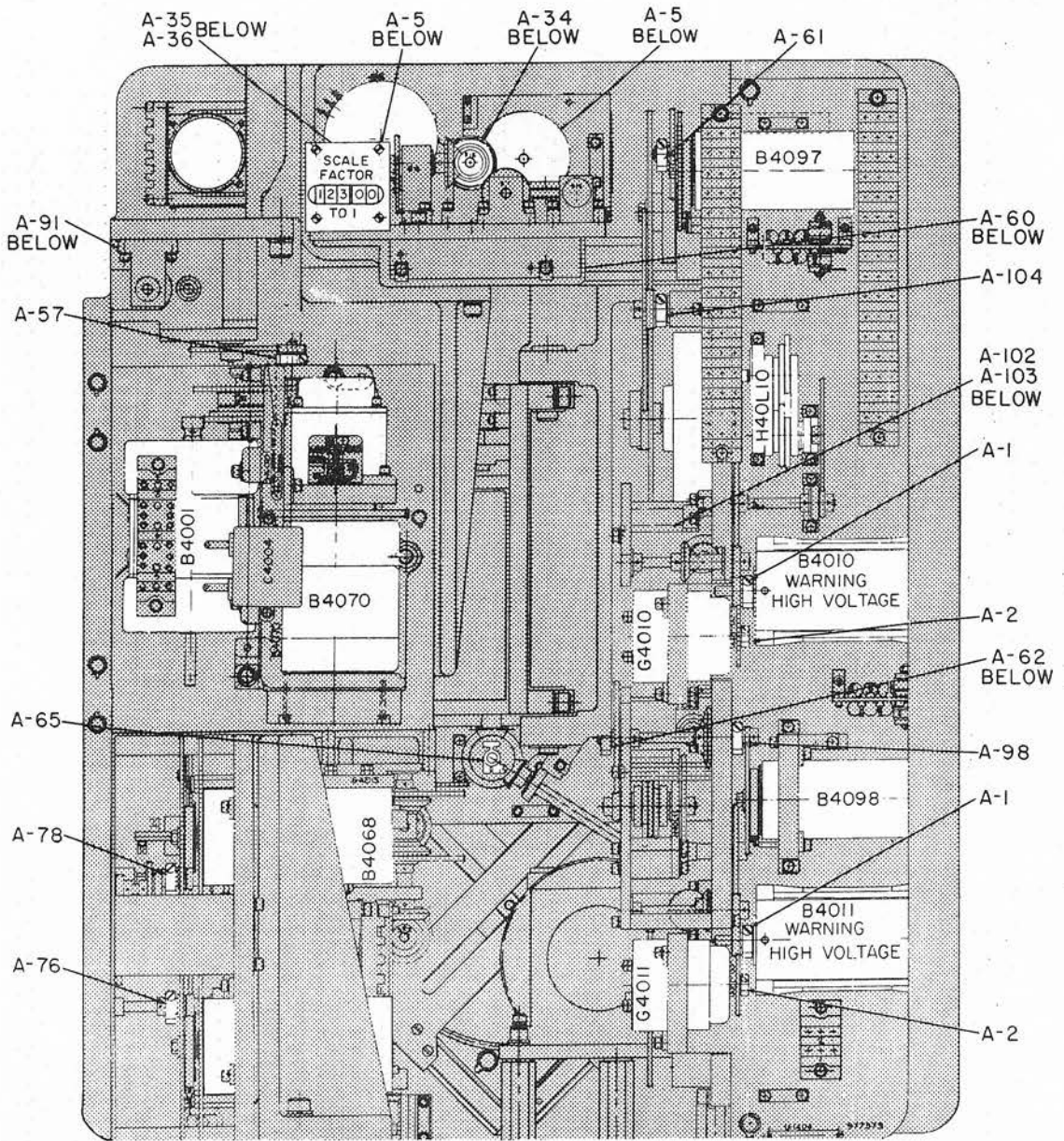

Figure 94. Rear Mechanical Section Under Cover No. 7

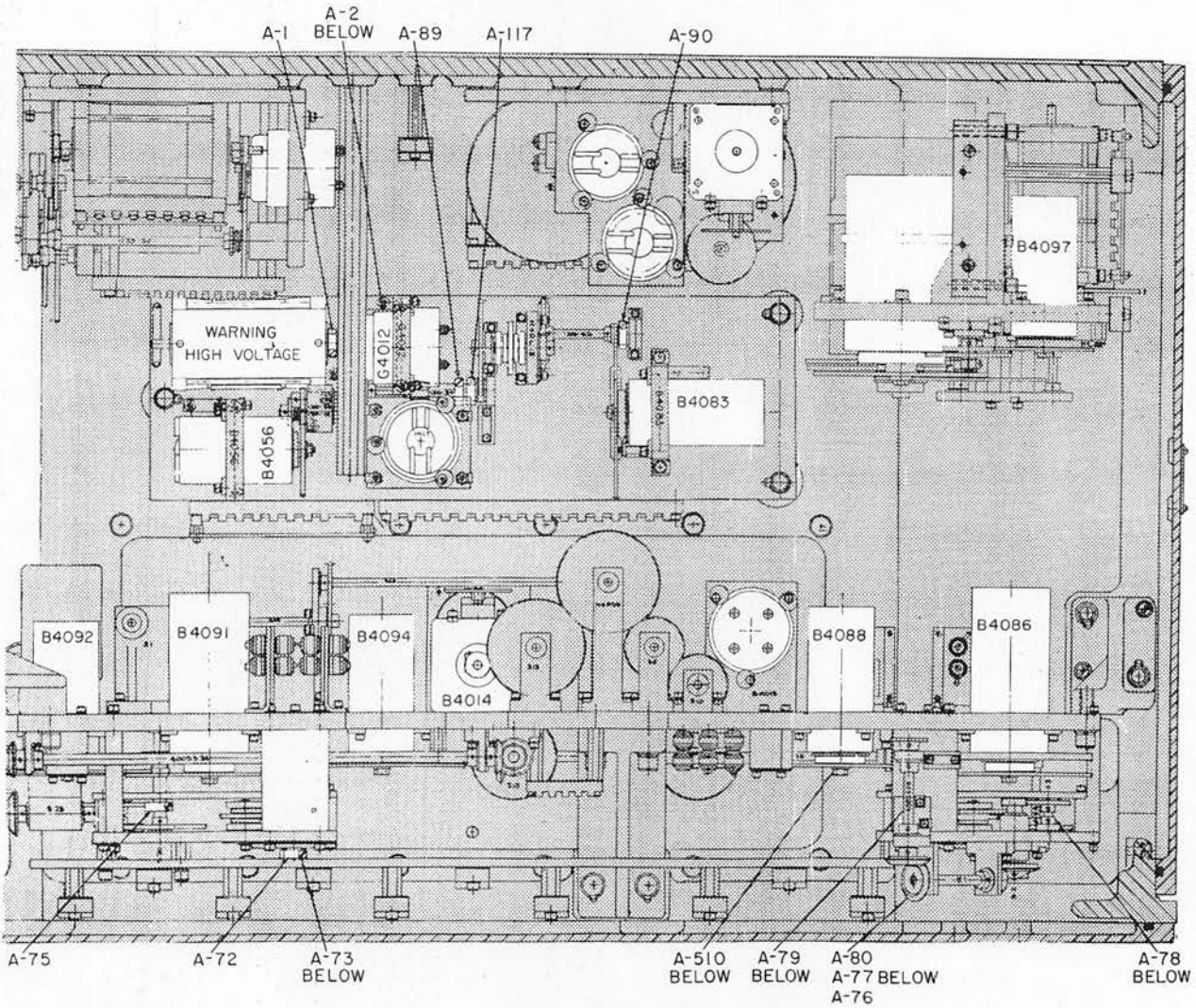

Figure 96. Lower Mechanical Section (Floor Plan)

Table 70 (Cont'd)

## ADJUSTMENT PROCEDURE

Adj No	Fig No	Function	Connection	Procedure
A5	90	Es	Pot R4018 to Es counter and stop H40L7	With pot at lower limit (rotate gear on pot full CW to attain this), set for a minimum resistance between slider (S) and ground (2). With Es = 2900 min, Zh = +25°, switch S4002 on MB position, TSS at 2B, check reading of +2.302.
None	--	jB	Resolver B4099 to servo motor B4004	With stops H40L16, H40L7, and H40L11 at midpoints of their travel, TSS at 2A, switch S4002 at MB, check test reading of zero. With Zh = +25°, Es = 3200 min, S4002 at MB, check reading at 2A = -2.307. Check that shaft 1201S4 will rotate 10 turns in each direction from midpoint of stop H40L16.
A67	89	Br + jB	Component solver U0621 to Br + jB line	With stops H40L14, H40L15, and H40L16 at midpoints of travel, and B'r' = 90°, set vector gear to produce no movement of output rack.
A66	89	So	So receiver to component solver U0621	With So on zero, set speed cam to produce no movement of output rack for 360° rotation of vector gear.
A68	89	$\Delta$ cR	Carriage of integrator H4004 to component solver U0621	With time motor running and U0621 set to zero output (as A66), set integrator to produce no movement of output roller. Check that component solver arm will travel 1.5 inches in either direction without hitting stops.
A116	89	$\Delta$ cR		

Table 70 (Cont'd)

## ADJUSTMENT PROCEDURE

Adj No	Fig No	Function	Connection	Procedure
None	--	$\Delta cR$	Transmitter B4073 to dial and H4004	With integrator H4004 set at zero output (see A68), set transmitter on electrical zero and dial at zero.
*A514	92	Ph	Dial to transmitter B4074	With transmitter on electrical zero, set dial on zero.
A44	92	Ph	Pot R4007 to dial	With transmitter and dial at zero, TSS at 1G, set pot R4007 to reading of zero.
A56	92	Ph	Stop H40L17 to dial	Set stop at $\pm 12$ degrees on dial.
None		R	Pot R4015 to range receiver	With B'r' = zero, R = 10,000 yds, TSS at 1F, check that pot is at zero. With B'r' = $90^\circ$ , R = 10,000 yds, check that reading at 1F is +0.105. If necessary to refine, use phasing clamp on pot R4015. See A109 for pot R4014.

\* Number not indicated in instrument.

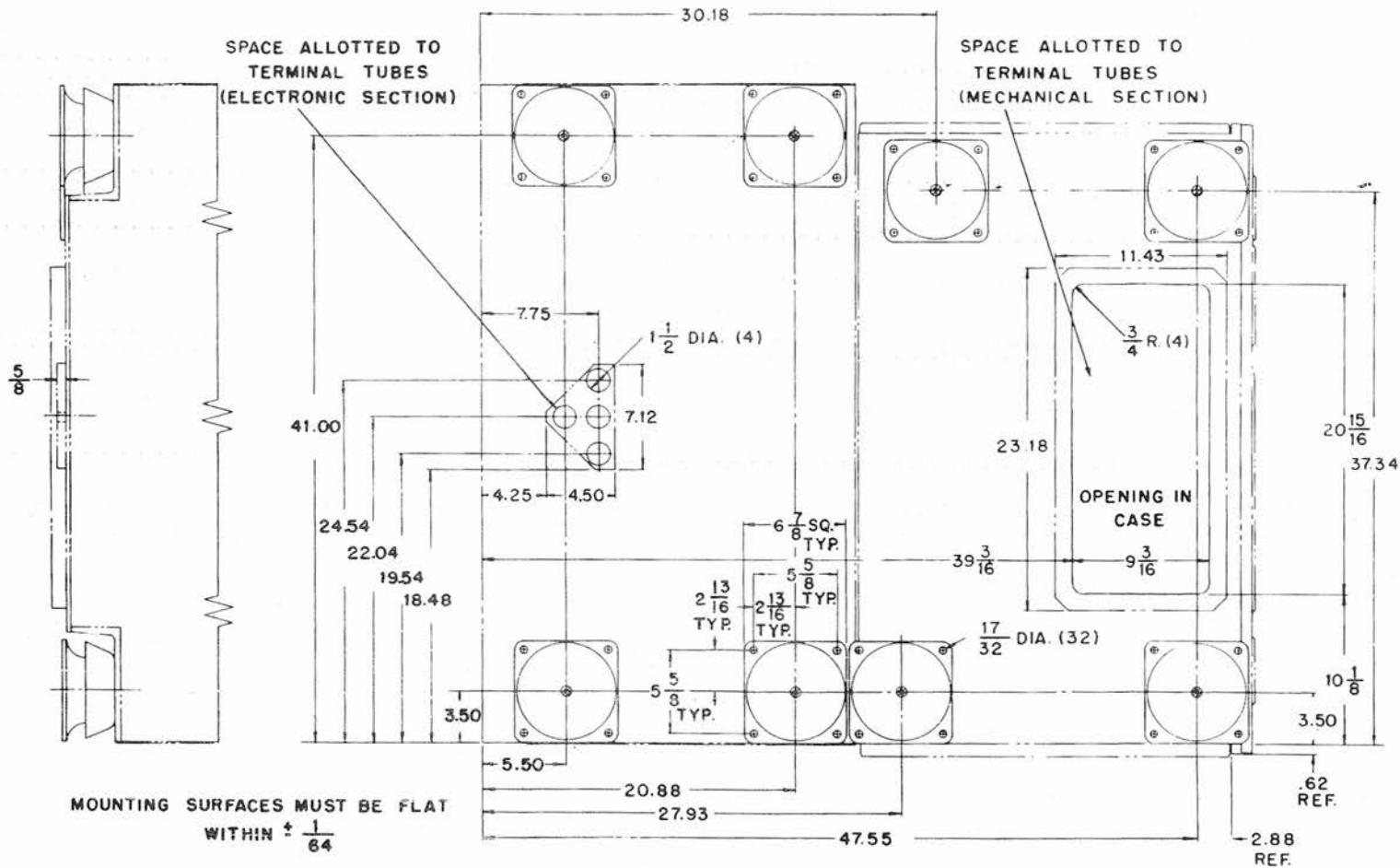

Figure 97. Computer Mk 48 Mod 1, Mounting Diagram

Chapter 6  
INSTALLATION

Figure 97 is a plan and side view of the bottom surface and shock mounts of the computer. As noted there, the surface on which the computer rests must be flat within  $\pm 1/64$  inch. Also shown are the terminal tube openings for the electronic and mechanical sections. Figures 98 and 99 show the interconnections between this computer and other elements of the fire control system.

Figure 100 shows the left side of the computer with both electronics drawers open for servicing. The blower removes hot air from the computer interior.

Table 71 lists operating voltages. The motor-generator set requires 3.5 kva (5.9 kva max) from the ship's 440-volt, 60-cycle, 3-phase supply.

Table 71  
OPERATING VOLTAGES

Voltage	Source	Where Used
6.3 volts, 60 cycles	T4101, T4102, T4103, T4301, and T4302	Filaments
Reference voltage $\pm 12$ volts, 400 cycles	ZY4101	Potentiometers and networks
+250-volts DC	ZC4101, ZC4102, and ZC4103	Servo controls, computing amplifiers, and tuning fork amplifier
+350-volts DC	Motor-Generator Set	Tuning fork amplifier, servo amplifiers, and series regulators (250v)
-105-volts DC	ZC4104	Servo amplifiers, tuning fork amplifier

RECEIVERS

TRANSMITTERS

SWITCHBOARD TO MECHANICAL SECTION CABLE #1  
 TERMINAL TUBE "J"  
 37-CONDUCTOR CABLE (MSCA-37)  
 29-COND. ACTIVE AND 8-COND. SPARE

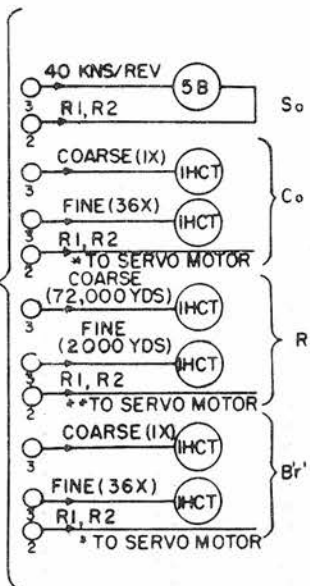

SWITCHBOARD TO MECHANICAL SECTION CABLE #2  
 TERMINAL TUBE "G"  
 24-CONDUCTOR CABLE (MSCA-24)  
 19-COND. ACTIVE AND 5-COND. SPARE

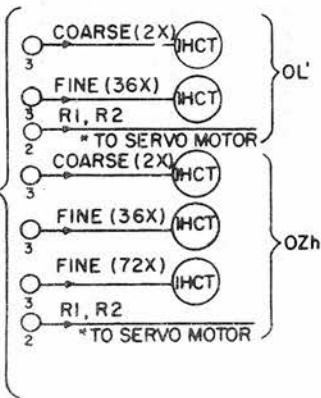

\* PROVIDE 30 WATTS FOR SERVO REQUIREMENTS  
 \*\* PROVIDE 15 WATTS FOR SERVO REQUIREMENTS  
 CABLE SIZES INDICATED ARE RECOMMENDED ONLY

SWITCHBOARD TO MECHANICAL SECTION CABLE #3  
 TERMINAL TUBE "J"  
 37-CONDUCTOR CABLE (MSCA-37)  
 33-COND. ACTIVE AND 4-COND. SPARE

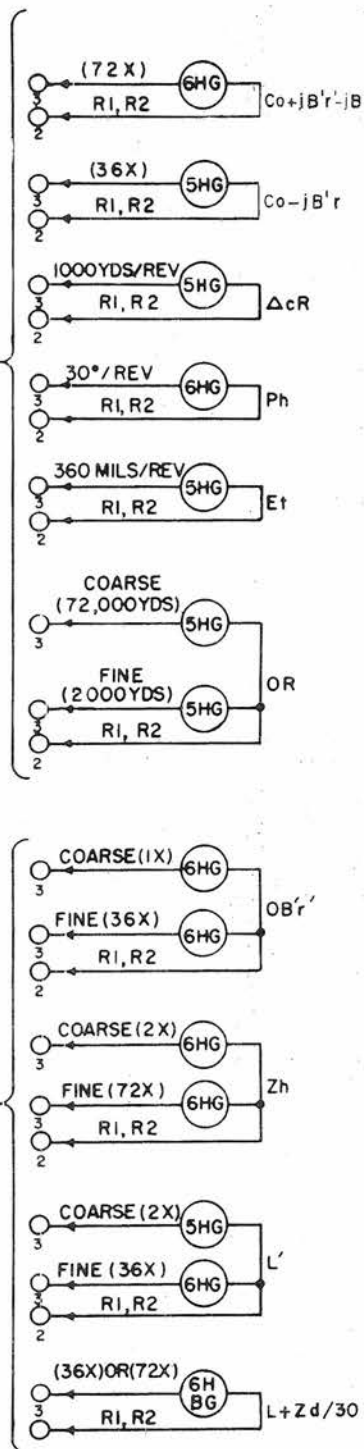

SWITCHBOARD TO MECHANICAL SECTION CABLE #4  
 TERMINAL TUBE "J"  
 37-CONDUCTOR CABLE (MSCA-37)  
 29-COND. ACTIVE AND 8-COND. SPARE

Figure 98. External Synchro Cable Connections

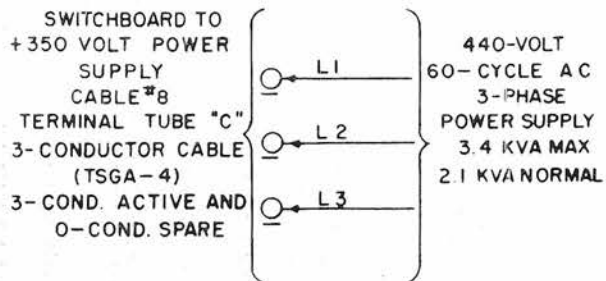
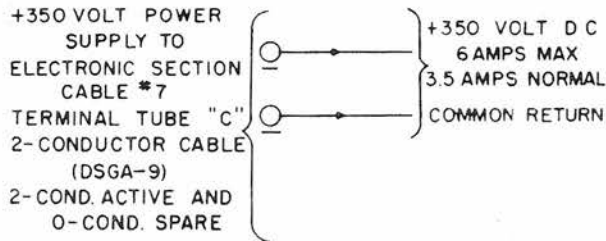
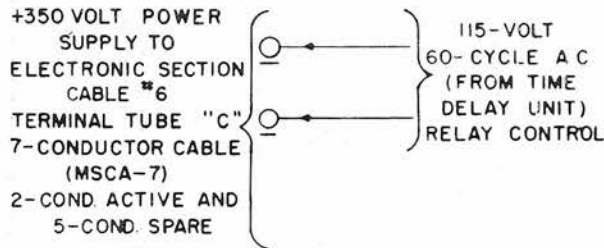
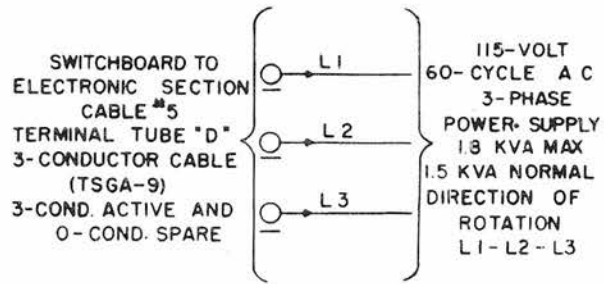

Figure 99. External Power Cable Connections

Table 70 (Cont'd)

## ADJUSTMENT PROCEDURE

Adj No	Fig No	Function	Connection	Procedure
A60	90	B	Resolver B4081 to line	With switch S4002 on AA, Co, B'r', jOB'r', jOB'r' - jB'r' = 0, Es = 2000 min, R = 40,000 yds. With mode switch S4006 on SHORE BOMB SHIP, TSS at 2C position, rotate resolver rotor CCW to a test reading of zero, decreasing. Turn TSS to 2D position, and check test reading of -9.400 v. With same set-up, but with S4006 on DEAD REK'NG-TGT, check that reading of TSS 2C = zero, increasing, and TSS 2D = +9.400.
A96	91	OB	Resolver B4082 to line	With switch S4006 on DEAD REK'NG-SHIP, Xj and Yj = 0, R = 50,000 yds, Es = 2000 min; 2D position on TSS, reading maximum plus voltage, put TSS on 3G position and rotate resolver gear CCW to a test reading of zero, increasing. Check that at TSS 3F, a positive signal, exists. Wind up spring sufficiently to remove lost motion in gearing.
A97	91	OB	Resolver B4082 to line	
*A505	91	OB	Dial to resolver B4082	With set-up A96 and A97 producing OB = zero, set coarse dial and vernier on 0°00'.
*A513	90	Et	Dial to synchro B4061	With transmitter B4061 on electrical zero, set dial to read 2000 minutes.
A83	90	Et	Dial to limit stop H40L4	Set stop to act between 2000 and 3200 minutes on dial.

\* Number not indicated on instrument.

Table 70 (Cont'd)

## ADJUSTMENT PROCEDURE

Adj No	Fig No	Function	Connection	Procedure
A82	90	Et	Resolver B4095 to stop H40L4	With stop at 3200 limit, turn resolver gear CCW until spring is wound tight. Back off 1/2 turn, and tighten clamp.
None	--	Et	Resolver B4095 to servo	With Et = 2000, Ht = zero, Et servo killed, max voltage indicated at TSS position 3F; rotate resolver rotor CCW to a reading of zero at TSS position 4B, and a negative reading at TSS position 4C.
*A511	90	OR	Dial to transmitter B4063	With synchros B4062 and B4063 on electrical zero, set OR dials to read 10,000 yds.
*A512	90	OR	Dial to transmitter B4062	
A111	90	OR	Transmitter B4063 to stop H40L8	Set stop to act between 500 yds and 50,000 yds on dials.
A113	90	OR	Transmitter B4062 to stop H40L8	Set stop to act between 500 yds and 50,000 yds on dials.
A112	90	OR	Pot R4008 to OR dials and stop H40L8	With TSS at 4D point, set pot to following: OR = 2000 yds, Reading = 0.470 Check at: OR = 5000 yds, Reading = 1.174. OR = 50,000 yds. Reading = 11.744.

\* Number not indicated on instrument.

Table 70 (Cont'd)  
ADJUSTMENT PROCEDURE

Adj No	Fig No	Function	Connection	Procedure
A110	90	OR	Pot R4021 and R4022 to stop H40L8	With OR at 50,000 yds, resistance between slider and terminal 1 of pots should be at minimum. Check to see that resistance increases as OR decreases.
A88	90	OB'r'	Synchro B4068 to B4069	Set transmitters together on electrical zero.
*A506	90	OB'r'	Dial to B4068	With synchros at electrical zero, set dials on zero.
*A507	90	OB'r'	Dial to B4069	
A87	90	OB'r'	OB'r' transmitter to line	With jOB'r', (jOB'r' - jB'r') dials on zero, Co, B'r', OB on zero, switch S4002 to AA position. Set OB'r' transmitter on zero.
A78	94	OB'r'	Resolvers B4086 and B4087 to OB'r' dials	With (jOB'r' - jB'r'), jOB'r', and OB'r' dials = 0, tighten clamp.
A75	--	OB'r - Br - jB	Resolver B4092 to line	With B'r', Co, OB, jOB'r' - jB'r', jOB'r' dials = 0, H40L16 wedged at midpoint; OB, jOB'r' - jB'r', jOB'r' servos killed, OL' = 0, OZh = 25°. TSS at 7A, rotate resolver rotor CCW to a test reading of zero, decreasing 7B reads -10.143.
*A509	--	OB'r - Br - jB	Dial to resolver B4092	With same set-up as for A75, set dial at zero.

\* Number not indicated on instrument.

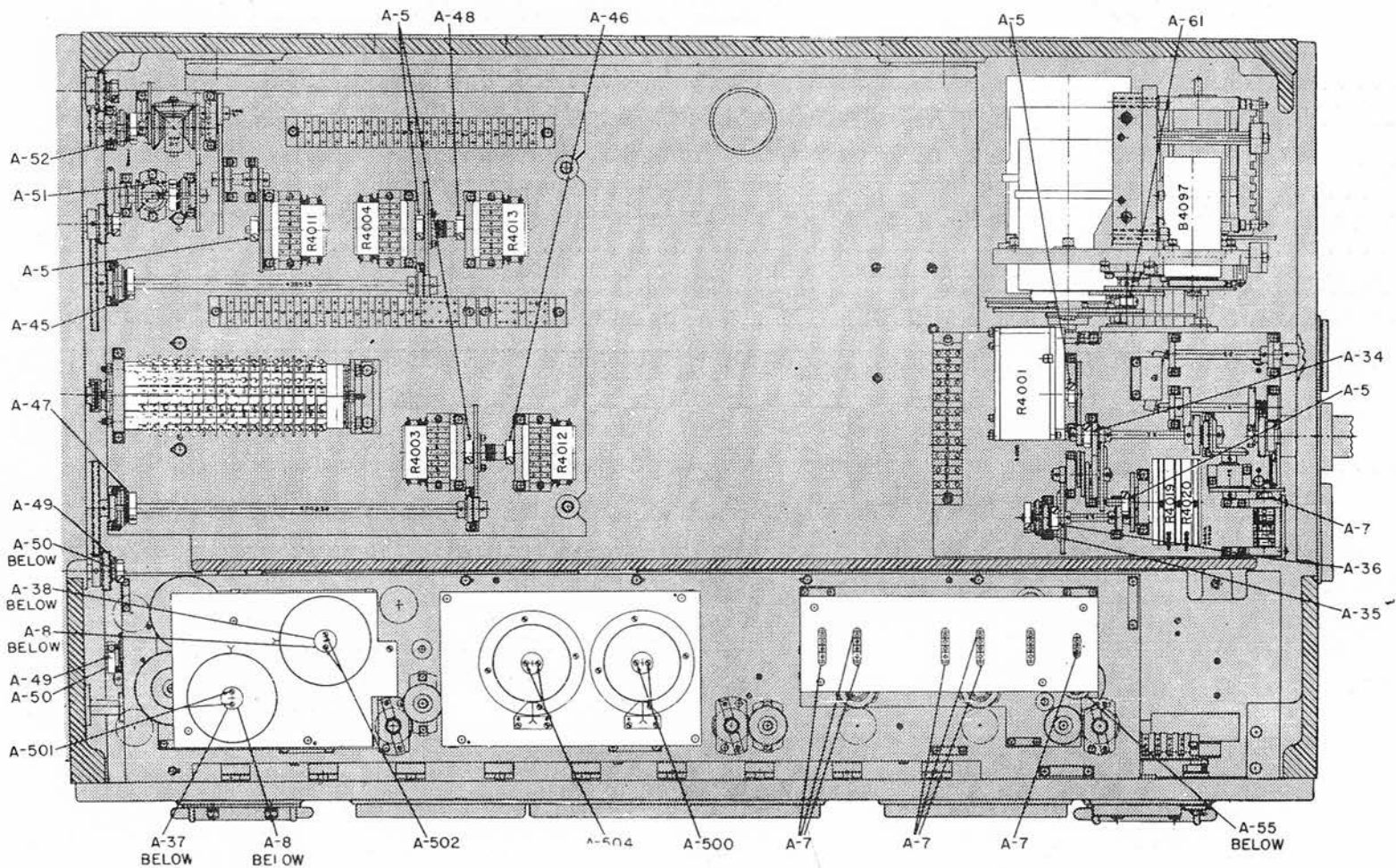

Figure 95. Top Mechanical Section Below Plotter and Cover No. 3

Table 70 (Cont'd)  
ADJUSTMENT PROCEDURE

Adj No	Fig No	Function	Connection	Procedure
None	--	jOB'r'	Resolver B4088 to stop H40L15	With jOB'r', jOB'r' - jB'r', OB'r', OBr - Br - jB dials on zero; jOB'r' and jOB'r' - jB'r' servos killed; S4002 on AA, proceed as follows: OL, OZd = 0°; rotate resolver rotor CCW to a reading of zero, decreasing, at TSS position 6A.
None	--	jOB'r'	Resolver B4059 to stop H40L15	OL, OZd = 25°; rotate resolver rotor CCW to a reading of +8.573 at TSS position 6G. With special probe, check B4089, R2 = 0.
None	--	jOB'r' - jB'r'	Resolver B4094 to stop H40L14	OL, OZd = 25°; rotate resolver rotor CCW to a reading of -8.573 at TSS position 6E. With special probe, check B4094. R2 = 0.
None	--	jOB'r' -jB'r'	Resolver B4093 to stop H40L14	OL, OZd = 0; rotate resolver rotor CCW to a reading of zero, increasing, at TSS position 5G.
None	--	2(OBr - Br - jB) - (jOB'r' - jB'r')	Resolver B4091 to stop H40L14	OL, OZd = 25°; rotate resolver rotor CCW to a reading of +8.573 at TSS position 6D. With special probe, check B4091. R2 = 0.
None	--	2(OBr - Br - jB) - (jOB'r' - jB'r')	Resolver B4090 to stop H40L14	OL = 0°, OZd = 25°; rotate resolver rotor CCW to a reading of zero, decreasing, at TSS position 6B.
None	--	2OB'r' + jOB'r'	Resolver B4086 to stop H40L15	OL = 0°, OZd = 25°; rotate resolver rotor CCW to a reading of zero, decreasing, at TSS position 5F.

Table 70 (Cont'd)

## ADJUSTMENT PROCEDURE

Adj No	Fig No	Function	Connection	Procedure
None	--	20B'r' + jOB'r'	Resolver B4087 to stop H40L15	OL, OZd = 25°; rotate resolver rotor CCW to a reading of -8.573 at TSS position 6F. With special probe, check B4087. R4 = 0.
A62	91	Zh	Assembly	Tighten
A100	91	Zh	Fine 6HG B4064 to limit stop H40L11	With stop H40L11 at midpoint of travel, set B4064 on electrical zero. Check that 160/32 gear on 6HG makes 5 turns in either direction from electrical zero.
A101	91	Zh	Coarse 6HG B4065 to fine 6HG B4064	Set fine and coarse synchros together on electrical zero.
A98	91	Zh	Resolver B4098 to limit stop H40L11	Turn shaft 1404S5 CCW (viewed from A98 end) until stop hits. Turn resolver gear CCW until take-up spring is wound solid. Back off 1/2 turn, and tighten A98.
None	--	Zh	Resolver B4098 to Zh line	With TSS at 7C position, Zh transmitters at electrical zero, rotate resolver rotor CCW to a test reading of zero, increasing. With special probe, check reading of +12.000 at R1 of B4098. With TSS at 7C position, Zh at 20° check reading of +4.104. Refine setting, if necessary.

Table 70 (Cont'd)

## ADJUSTMENT PROCEDURE

Adj No	Fig No	Function	Connection	Procedure
A103	91	L'	Fine 6HG B4067 to limit stop H40L10	With stop H40L10 at midpoint of travel, set B4067 at electrical zero. Check that 48/32 gear on 6HG makes 2.5 turns in either direction from electrical zero.
A104	91	L'	Coarse 5HG B4075 to fine 5HG B4067	Set fine and coarse synchros together on electrical zero.
A61	91	L'	Resolver B4097 to limit stop H40L10	Rotate shaft 1404S13 CW (viewed from A61 end) until stop H40L10 hits. Loosen clamp A61, and rotate shaft 1404S13 CW until take-up spring is wound solid. Back off 1/2 turn, and tighten A61.
None	--	L'	Resolver B4097 to L' line	With TSS at 7D position, L' transmitters on electrical zero, rotate resolver rotor CCW to a test reading of zero, increasing. With special probe, check reading of +12.000 at R1. With TSS at 7D position, L' at +20°, check reading of +4.104. Refine setting, if necessary.
A99	91	L' + Zd/ 30	6HBG B4066 stator to stop H40L11	With limit stops H40L10 and H40L11 at midpoints of their travel, set 6HBG (B4066) at electrical zero.
A102	94	L' + Zd/ 30	6HBG B4066 rotor to stop H40L10	

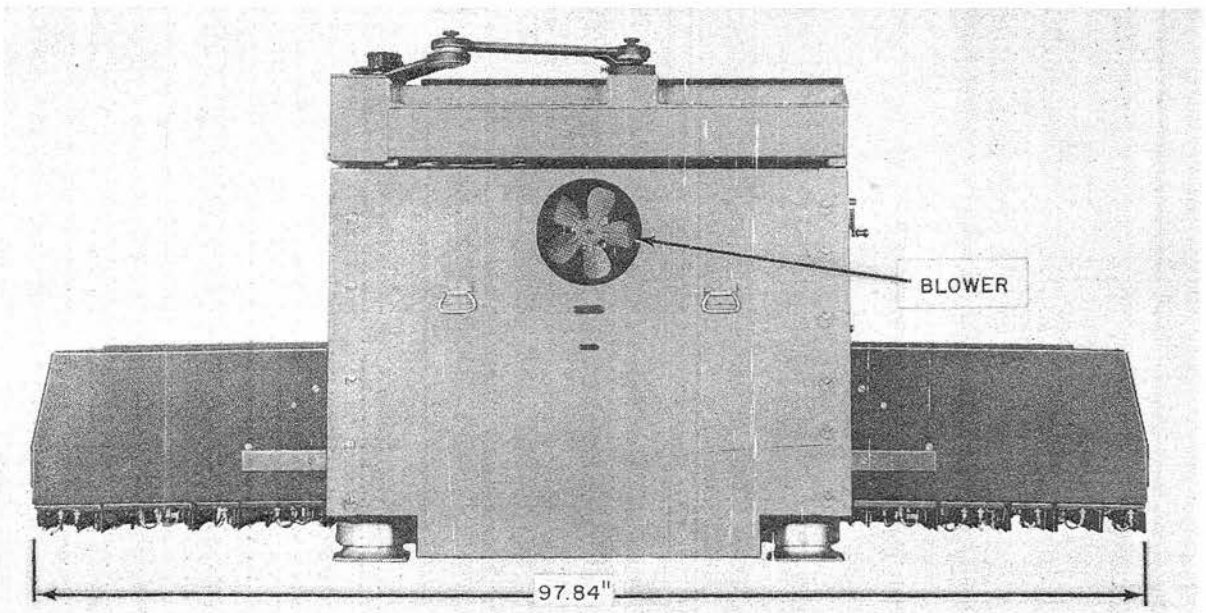

Figure 100. Left Side with Electronic Drawers Extended

As manufactured, the L + Zd/30 transmitter is designed for Mark 37 directors having the Amplidyne drive (36x, 10 degrees per revolution). Change gears for the Arma drive (72x, 5 degrees per revolution) and a change gear chart are attached inside the rear cover (cover No. 7) of the mechanical section. These gears can be mounted on shafts 1404S7, 1404S8, and the transmitter, B4066, as shown on the chart. The position of the entire unit in the computer is shown at the right side of figure 91.

Train control,  $Co + jB'r' - jB$ , is transmitted by a 36x (10 degrees per revolution) synchro transmitter and also by a 72x (5 degrees per revolution) synchro transmitter. The 36x transmitter is for Mark 37 directors with the Amplidyne drive. The 72x transmitter is for Mark 37 directors with the Arma drive and for other equipment with 72x train control receivers. When the computer is installed, each train control transmitter must be connected to the proper receiver. Specific transmission information for the various installations is given in table 72.

Table 72

## TRANSMISSION INFORMATION FOR INSTALLATION

Function	Mk 34	Mk 38	Mk 54	Antenna Mt Mk 23	Mk 37
Level	36x	36x	36x	2 and 36x	
L + Zd/30					Arma 72x Drives 36x Amplidyne Ordalt 2815
Cross Level					2 and 72x
Train Control	72x	72x	72x	72x	Arma 72x Drives 36x Amplidyne
Increments of Range $\Delta cR$	1000 yds/t	1000 yds/t	1000 yds/t	1000 yds/t	1000 yds/t
Unit Parallax (Ph)				12x	12x <sup>1</sup>

1. In the Mk 37 a fixed vertical parallax correction is made for a 10-yard base length.

Table 72 (Cont'd)

## TRANSMISSION INFORMATION FOR INSTALLATION

Function	Mk 34	Mk 38	Mk 54	Antenna Mt Mk 23	Mk 37
Parallax Range	Manual <sup>2</sup> Sight Angle Dial Only	Manual Range Dial	Manual <sup>3</sup> Range Dial		
SHIPS	CL's CA's	BB's	CA's 134, 139, 148	CL 144, 145	DD's, CL's CA's, BB's

2. Also sets vertical parallax. A sight angle vs range conversion table is required.
3. Separate inputs for horizontal and vertical parallax. Parallax range, K/R, is received automatically in normal operation.

Appendix A  
SUPPLEMENTARY DATA

## DIAGRAMS

<u>Title</u>	<u>BuOrd Dwg</u>
Horizontal Section	1371751
Deck-Tilt Section	1371753
Computing Networks	1371765
Deck-Tilt Corrector Networks	1371764
Power Supply	1371754
Neon Test-Control Circuit	1371755
Gearing of Computing Mechanisms	1372018, 1372019
Control Circuit Diagram	1372106
External Cable Connections	1371758
Wiring of Mechanical Sections:	
Unit 4007	1436062
Unit 4007 (Terminal Blocks)	1436063
Unit 4004 and 4006	1436064
Unit 4004	1436065
Unit 4005	1436066
Unit 1401 to 1403	1436067
Unit 1201, 1202, 1405, 1406	1436068
Unit 1203, 1301, 1305	1436069
Unit 1302, 1304, 1404	1436070
Unit 4008, 4009, 1310	1436071

## Appendix A (Cont'd)

<u>Title</u>	<u>BuOrd Dwg</u>
Wiring of Electronic Sections:	
Terminal Blocks Section 4100	1436073
Bottom and Right Side of Case and Jack Plate	1436074
Terminal Blocks Section 4300	1436075
Front Drawer, Front View	1436076
Front Drawer, Rear View	1436077
Networks and Power Supply	1436078
Rear Drawer, Rear View	1436079
Rear Drawer, Front View	1436080
Relay Bracket, Rear Right, Front, and Top Views	1436081
Relay Terminal Blocks Section 4300	1372099
Servo Unit Plotter Drive	1436072
Interconnecting (Computer Section to Electronic Section)	1436060, 1436061

## ASSEMBLY DRAWINGS

<u>Title</u>	<u>BuOrd Dwg</u>	<u>Unit No</u>
Test Unit	1371830	--
Blower Assembly	981044	0905
Mechanical, Main Assembly	1371960 to 1371967	--
Horizontal Bearing Correction Assembly (jB)	1371693, 1371694	1201
Sight Elevation (Es)	980640, 980641	1202
True Target Bearing (OB)	980709, 980710	1203
Plotter Drive	980225	1204
Level Receiver (OL')	980660, 980661	1301

## Appendix A (Cont'd)

<u>Title</u>	<u>BuOrd Dwg</u>	<u>Unit No</u>
Own Ship Course Receiver (Co)	1371624	1302
Cross-Level Receiver (OZh)	1371640, 1371641	1304
Director-Train Receiver (B'r')	1371637, 1371638	1305
Ship's Speed Receiver (So)	981171	1310
Relative Target Bearing Transmitter (OB'r')	981182	1401
Target Range Transmitter (OR)	1371708, 1371709	1402
Target Elevation Transmitter (Et)	981408, 981409	1403
Level and Cross-Level Transmitters (L), (Zh)	1371779-1371785	1404
Parallax Transmitter (Ph)	981040, 981041	1405
Bearing-Aided Tracking Transmitters (Co + jB'r' - jB)	1371748, 1371749	1406
Motor Regulator	195022	1601
Dial Gearing and Range Receiver	1371885	4004
Deck-Tilt Corrector	1371737 to 1371474	4005
Terminal Block Assembly	1371972	4007

## Appendix A (Cont'd)

## LIST OF ELECTRON TUBES

<u>Tube Type</u>	<u>Quantity</u>	<u>Quantity per Electronic Unit</u>
OA2WA	17	3201 (1)
OA3	1	3804 (1)
OB2WA	8	3304 (1), 3305 (1), 3803 (1)
5651WA	1	3804 (1)
5726/6AL5W	52	3301 (3), 3302 (5), 3305 (2)
5751	51	3002 (2), 3012 (2), 3201 (1), 3301 (1), 3302 (1), 3304 (1), 3305 (1), 3402 (1), 3803 (1), 3804 (1)
5814A	21	3002 (2), 3012 (2), 3302 (1), 3305 (1), 3402 (1)
5932	36	3201 (2), 3402 (2)
6005/6AQ5W	16	3001 (1), 3011 (1), 3301 (1), 3302 (1)
6080WA	7	3803 (2), 3804 (1)
6AU6WA	30	3001 (2), 3011 (2), 3301 (1), 3305 (1), 3302 (2), 3401 (2)
6AV6	5	3304 (1), 3305 (1)
6X4W	2	3804 (2)
12AT7WA	17	3201 (1)
	264 Total	

## Appendix A (Cont'd)

## MOTOR-GENERATOR SET DRAWINGS

<u>Title</u>	<u>Bureau of Ships</u>	<u>Standard Navy Stock Number</u>
Rheostat	S6307-3175735	S17-R-7456-1255
Controller	S6307-769124	S17-C-34264-204
Regulator	---	S17-R-57259-972
Motor-Generator	S6104-3244924	S17-M-69593-7415
On-board Repair Parts	S6104-1559380	S17-M-133502-4675
	S6104-1559381	
	S6104-1559382	
	S6104-1559383	
	S6104-1559384	
	S6104-1559385	

## INSTALLATION DRAWINGS

<u>Title</u>	<u>BuOrd Dwg</u>
Navy lead designation assembly	1225505
Navy lead designation assembly	1225506
Navy lead designation assembly	1225507
General arrangement plan view	1371724
General arrangement front view	1371725
General arrangement left side view	1371726
General arrangement right side view	1371727
General arrangement rear view	1371729
General arrangement terminal tubes and mounting dimensions for computer	1371730
External cable connection diagram	1371758
Handle storage shelf assembly	13721001
Wiring diagram mechanical section (Unit 4007)	1436062

## Appendix A (Cont'd)

---

<u>Title</u>	<u>BuOrd Dwg</u>
Wiring diagram mechanical section (Unit 4007) (terminal blocks)	1436063
Terminal blocks section 4100 wiring diagram	1436073
Master drawing motor generator set	S6104-H-3, 244, 924
Master drawing field rheostat, NOrd(z)14048, NOrd(z)14049	S6308-F-3, 175, 735
Master plan controller NOrd(z)14048, NOrd(z)14049	94104-S6307-769, 124
Master drawing voltage regulator, C/D NOrd(z)14048, NOrd(z)14049	S6104-3, 264, 661
Master plan pushbutton NOrd(z)14048, NOrd(z)14049	S6307-F-3, 000, 793

---

## INDEX TO LISTS OF DRAWINGS

COL. NO. 1	2	3	4	5	6	7	8
LISTS OF DRAWINGS NUMBER	"X" INDICATES RELATIVE POSITION IN ASSEMBLY						NOMENCLATURE
L.D.294834	X						COMPUTER MK.48 MOD.1 GENERAL ARRANGEMENTS
L.D.290650		X					PLOTTER, MAIN ASSEMBLY
L.D.290651			X				PLOTTER LIGHT RAIL ASSEMBLY
L.D.290648			X				PLOTTER DRIVE SERVO
# ORD. SK.276506				X			10 WATT SERVO MOTOR 60 CYCLES
ORD. SK.276842				X			POTENTIOMETER (30 TURNS)
L.D.290649				X			GENEVA & LIMIT STOP
L.D.294893				X			COUNTER ASSEMBLY
L.D.294894				X			COUNTER ASSEMBLY
L.D.295104				X			MECHANICAL SECTION CABLE ASSEMBLIES & OUTLINE
L.D.295052					X		CABLE NO.107
L.D.295053					X		CABLE NO.108
L.D.294837		X					MAIN ASSEMBLY, MECHANICAL
L.D.290640			X				SERVO & RESOLVER ASSEMBLY
# L.D.290566				X			SELF COMPENSATING RESOLVER ROTOR UNLIMITED
L.D.295102				X			MECHANICAL SECTION CABLE ASSEMBLIES & OUTLINE
L.D.295049					X		CABLE NO.104
L.D.295050					X		CABLE NO.105
L.D.290647			X				RESOLVER & GEARING ASSEMBLY
# ORD. SK.276506				X			10 WATT SERVO MOTOR 60 CYCLES
# L.D.290566				X			SELF COMPENSATING RESOLVER ROTOR UNLIMITED
L.D.290567				X			VECTOR SOLVER RESOLVER SELF-COMPENSATING
# L.D.290587				X			SELF-COMPENSATING RESOLVER BEARING MOUNTED
# L.D.294930				X			RESOLVER (SPECIALLY TRIMMED)
# L.D.290566					X		SELF-COMPENSATING RESOLVER ROTOR UNLIMITED
L.D.294932				X			RESOLVER (SPECIALLY TRIMMED)
# L.D.290587					X		SELF-COMPENSATING RESOLVER BEARING MOUNTED
L.D.294943				X			RESOLVER (SPECIALLY TRIMMED)
# L.D.290566					X		SELF-COMPENSATING RESOLVER ROTOR UNLIMITED
L.D.295117				X			MECHANICAL SECTION CABLE ASSEMBLIES & OUTLINE
L.D.295079					X		CABLE NO.134
L.D.295080					X		CABLE NO.135
L.D.295081					X		CABLE NO.136
L.D.295082					X		CABLE NO.137
L.D.295083					X		CABLE NO.138
L.D.295084					X		CABLE NO.139
L.D.295085					X		CABLE NO.140
L.D.295086					X		CABLE NO.141

L.D. NO. 294835  
SHEET NO. 2ITEMS MARKED THIS (#) APPEAR MORE THAN ONCE.  
L.D.'S MARKED THIS (\*) NOT TO BE FURNISHED UNLESS ESPECIALLY ORDERED.

INDEX TO LISTS OF DRAWINGS							
COL. NO. 1	2	3	4	5	6	7	8
LISTS OF DRAWINGS NUMBER	"X" INDICATES RELATIVE POSITION IN ASSMBLY						NOMENCLATURE
L.D.,295087					X		CABLE NO.142
L.D.,290652			X				SERVO & TRANSMITTER ASSEMBLY
L.D.,295114				X			MECHANICAL SECTION CABLE ASSEMBLIES & OUTLINE
L.D.,295071					X		CABLE NO.126
L.D.,295072					X		CABLE NO.127
L.D.,295073					X		CABLE NO.128
L.D.,290653			X				SINGLE SPEED RESOLVER ASSEMBLY
ORD, SK,60882				X			1150 H.P. A.C. MOTOR
ORD, SK,63395				X			MAGNETIC DRAG
L.D.,295109				X			MECHANICAL SECTION CABLE ASSEMBLIES & OUTLINE
L.D.,295061					X		CABLE NO.116
L.D.,295062					X		CABLE NO.117
L.D.,290655			X				DOUBLE SPEED RESOLVER ASSEMBLY
# ORD, SK,276506				X			10 WATT SERVO MOTOR
L.D.,295055				X			MECHANICAL SECTION CABLE NO.110
L.D.,290656			X				DOUBLE SPEED RESOLVER ASSEMBLY
# ORD, SK,276506				X			10 WATT SERVO MOTOR 60 CYCLES SELF-COMPENSATING RESOLVER ROTOR UNLIMITED
# L.D.,290566				X			RESOLVER (SPECIALLY TRIMMED)
L.D.,294931				X			RESOLVER ASSEMBLY
L.D.,290641					X		MECHANICAL SECTION CABLE ASSEMBLIES & OUTLINE
L.D.,295107				X			CABLE NO.111
L.D.,295056					X		CABLE NO.112
L.D.,295057					X		CABLE NO.113
L.D.,295058					X		SERVO & RESOLVER ASSEMBLY SELF-COMPENSATING RESOLVER ROTOR UNLIMITED
L.D.,290659			X				MECHANICAL SECTION CABLE ASSEMBLIES & OUTLINE
# L.D.,290566				X			CABLE NO.101
L.D.,295101				X			CABLE NO.102
L.D.,295046					X		CABLE NO.103
L.D.,295047					X		DOUBLE SPEED RESOLVER ASSEMBLY
L.D.,295048					X		10 WATT SERVO MOTOR
L.D.,290660			X				RESOLVER (SPECIALLY TRIMMED)
# ORD, SK,276506				X			SELF-COMPENSATING RESOLVER ROTOR UNLIMITED
# L.D.,294930				X			MECHANICAL SECTION CABLE ASSEMBLIES & OUTLINE
# L.D.,290566					X		CABLE NO.159
L.D.,295105				X			CABLE NO.109
L.D.,295051					X		DOUBLE SPEED RESOLVER ASSEMBLY
L.D.,295054					X		
L.D.,290661			X				

L D NO. 294835

ITEMS MARKED THUS (#) APPEAR MORE THAN ONCE.  
L D'S MARKED THUS (o) NOT TO BE FURNISHED UNLESS ESPECIALLY ORDERED.

# INDEX TO LISTS OF DRAWINGS

INDEX TO LISTS OF DRAWINGS							
COL. NO. 1	2	3	4	5	6	7	8
LISTS OF DRAWINGS NUMBER	"X" INDICATES RELATIVE POSITION IN ASSEMBLY						NOMENCLATURE
# ORD. SK, 276506				X			10 WATT SERVO MOTOR 60 CYCLES
# L.D. 290566				X			SELF-COMPENSATING RESOLVER ROTOR UNLIMITED
L.D. 295108				X			MECHANICAL SECTION CABLE ASSEMBLIES & OUTLINE
L.D. 295059					X		CABLE NO. 114
L.D. 295060					X		CABLE NO. 115
L.D. 290673			X				TRANSMITTER & SERVO ASSEMBLY
# ORD. SK, 276842				X			POTENTIOMETER (30 TURNS)
L.D. 295111				X			MECHANICAL SECTION CABLE ASSEMBLIES & OUTLINE
L.D. 295064					X		CABLE NO. 119
L.D. 295065					X		CABLE NO. 120
L.D. 295066					X		CABLE NO. 121
L.D. 290674			X				TRANSMITTER & SERVO ASSEMBLY
L.D. 290567				X			RESOLVER, VECTOR SOLVER
L.D. 295112				X			MECHANICAL SECTION CABLE ASSEMBLIES & OUTLINE
L.D. 295067					X		CABLE NO. 122
L.D. 295068					X		CABLE NO. 123
L.D. 290675			X				SERVO & RESOLVER ASSEMBLY
# ORD. SK, 276506				X			10 WATT SERVO MOTOR 60 CYCLES
# L.D. 290567				X			VECTOR SOLVER RESOLVER SELF-COMPENSATING
L.D. 295103				X			MECHANICAL SECTION CABLE NO. 106
L.D. 294841			X				TRANSMITTER ASSEMBLY
L.D. 295063				X			ELECTRONIC SECTION CABLE NO. 118
L.D. 294844			X				TRANSMITTER ASSEMBLY
L.D. 295074				X			MECHANICAL SECTION CABLE NO. 129
L.D. 294851			X				GEARING ASSEMBLY
# ORD. SK, 276842				X			POTENTIOMETER ASSEMBLY
# ORD. SK, 295395				X			ROTARY SWITCH ASSEMBLY
L.D. 295091				X			MECHANICAL SECTION CABLE NO. 146
L.D. 294853			X				TRANSMITTER & SERVO ASSEMBLY
# ORD. SK, 276506				X			10 WATT SERVO MOTOR 60 CYCLES
# L.D. 294930				X			RESOLVER (SPECIALLY TRIMMED)
# L.D. 290566					X		SELF-COMPENSATING RESOLVER ROTOR UNLIMITED
L.D. 295113				X			MECHANICAL SECTION CABLE ASSEMBLIES & OUTLINE
L.D. 295069					X		CABLE NO. 124
L.D. 295070					X		CABLE NO. 125
L.D. 294856			X				SCALE FACTOR ASSEMBLY
ORD. SK, 137396				X			POTENTIOMETER (30 TURNS)
L.D. 294845				X			COUNTER ASSEMBLY

L.D. NO. 294835  
SHEET NO. 4

ITEMS MARKED THUS (#) APPEAR MORE THAN ONCE.  
L.D.'S MARKED THUS (\*) NOT TO BE FURNISHED UNLESS ESPECIALLY ORDERED.

## INDEX TO LISTS OF DRAWINGS

COL. NO. 1	2	3	4	5	6	7	8
LISTS OF DRAWINGS NUMBER	"X" INDICATES RELATIVE POSITION IN ASSEMBLY						NOMENCLATURE
L.D.295120				X			MECHANICAL SECTION CABLE ASSEMBLIES & OUTLINE
L.D.295092					X		CABLE NO.147
L.D.295093					X		CABLE NO.148
L.D.294868			X				DIAL GEARING AND RECEIVER
ORD. SK.63393				X			PUSH SWITCH ASSEMBLY
# ORD. SK.276842				X			POTENTIOMETER (9.5 TURNS)
L.D.294890				X			COUNTER ASSEMBLY
L.D.294891				X			COUNTER ASSEMBLY
L.D.294920				X			COUNTER ASSEMBLY
L.D.294957				X			POTENTIOMETER (1 TURN)
L.D.294958				X			COUNTER ASSEMBLY
L.D.295116				X			MECHANICAL SECTION CABLE ASSEMBLIES & OUTLINE
L.D.295075					X		CABLE NO.130
L.D.295076					X		CABLE NO.131
L.D.295077					X		CABLE NO.132
L.D.295078					X		CABLE NO.133
L.D.294887			X				COMPONENT SOLVER INTEGRATOR MOUNTING & GEARING ASSEMBLY
# L.D.290587				X			SELF-COMPENSATING RESOLVER BEARING MOUNTED
L.D.294857				X			1 1/2" COMPONENT SOLVER AND INTEGRATOR MOUNTING
L.D.294859				X			2 1/2" COMPONENT SOLVER
L.D.295118				X			MECHANICAL SECTION CABLE ASSEMBLIES & OUTLINE
L.D.295088					X		CABLE NO.143
L.D.295089					X		CABLE NO.144
L.D.295090					X		CABLE NO.145
L.D.294901			X				CASE & COVERS ASSEMBLY
L.D.294858				X			HANDLE ASSEMBLY
L.D.294874				X			HANDLE ASSEMBLY
L.D.294876				X			HANDLE ASSEMBLY
L.D.294877				X			HANDLE ASSEMBLY
L.D.294878				X			HANDLE ASSEMBLY
L.D.294879				X			HANDLE ASSEMBLY
L.D.294880				X			HANDLE ASSEMBLY
L.D.294881				X			HANDLE ASSEMBLY
L.D.294882				X			HANDLE ASSEMBLY
L.D.294883				X			HANDLE ASSEMBLY
L.D.294884				X			HANDLE ASSEMBLY
L.D.294885				X			HANDLE ASSEMBLY
L.D.295115				X			MECHANICAL SECTION CABLE ASSEMBLY & OUTLINE

L.D. NO. 294835  
SHEET NO. 5ITEMS MARKED THUS (#) APPEAR MORE THAN ONCE.  
L D'S MARKED THUS (\*) NOT TO BE FURNISHED UNLESS ESPECIALLY ORDERED.

DISTRIBUTION:

SNDL Part 1 (No. 67) and Part 2 (No. 25)

Two copies each unless otherwise excepted:

21(CINCPAC and CINCLANT); 24C(COMCRUDESPAC and COMBATCRULANT), 24F; 29A(5 copies), 29B, 29D; J4, J33(Great Lakes); K6A(Ford Instrument); L1(Boston, Norfolk, San Francisco, Long Beach and Mare Island only)(6 copies each).

Requests for additional copies of OP 2074 should be submitted on NAVSANDA Form 43, Requisition and Invoice, to the appropriate Forms and Publications Supply Point in accordance with BUSANDAINST 5604.1.